

WOLONG
Power your future

Buyers Guide

Direct Current Motors
1 to 3000 HP



Our DC Motors Last! And we back up that claim.

GE direct current motors are legendary in the industry for their durability, reliability, and longevity!

We have over 100 years of experience of direct current motor engineering and manufacturing utilizing superior design and quality control systems. These machines are a proven reliable lifeline to driven equipment and the backbone of thousands of operations around the world.

- They are constructed in a rugged magnetic ring frame for severe industrial duty applications.
- They feature anti friction bearings with removable bearing cartridges and caps.
- Fully compliant class F insulation (CD) and class H insulation (MD).
- Strong Tungsten Inert Gas (TIG) welded commutator risers to the armature coil.
- Tape Reinforced Encapsulated Construction (TREC) of main field coils and commutating field coils is a process which strengthens, seals, and bonds the coil and pole into a single unit highly resistant to contaminants.



As of July, 2024 Wolong is offering a 5 year manufacturer's warranty on these GE direct current motor models:

Mill-Duty Series

MD600Z, MD800

CD Series

CD6000, CD8000, CD9000,
and MCF Generators

The warranty is valid for the period of 54 months from the date of installation or 60 months from the date of manufacture, whichever comes first, guaranteeing to the Buyer that the provided product will be free from defects in material, workmanship, and title. For more information, please contact your Wolong representative.

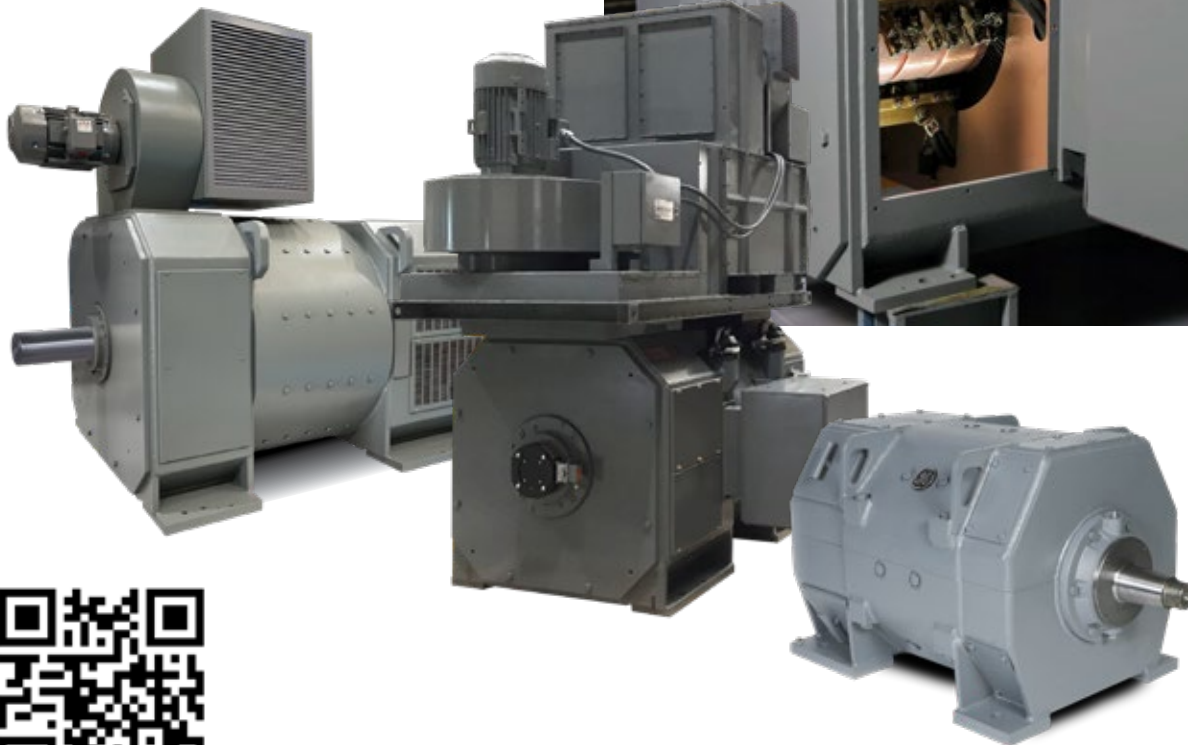

www.wolongamerica.com

DC Motor Buyers Guide

Table of Contents

General Information	Section 1
Motor Pricing	Section 2
Accessories and Modifications	Section 3
Outline Dimensions	Section 4
Application Information	Section 5
Other Information	Section 6

General Information

Index

	Page
General Description	1.2
Enclosures	1.3
Air Flow Schematics: CD180AT through CD6900 Frames	1.5
Replacement Motors	1.7
Motor Cutaway: Kinamatic™	1.8
Basic Requirement Instructions	1.10
Minimum Data Check Sheet	1.11
Pump Motors: CD180AT through CD6900 Frames	1.12

General Description

Introduction

Designed to meet NEMA specifications, The complete line of DC motor offerings are available to meet all of your DC motor needs. The Kinamatic™ and CD6000 series of motors featured in this publication are a result of many years of research and development. Quality components and craftsmanship are designed to provide years of dependable motor performance.

Frames

Rugged magnetic ring frame construction of Kinamatic motors and heavy duty fabricated CD6000 frames designed for optimum motor performance.

Bearings

Antifriction bearings permit mounting of standard CD320AT and below frame sizes at any angle and CD365AT-CD5010AY frames mounted vertical shaft down. For easy maintenance, CD6000 have antifriction bearings and removable bearing cartridges and caps.

Insulation

Kinamatic and CD6000 series DC motors have Class F insulation containing a number of components rated Class H, unless otherwise specified.

The insulation system employs many proprietary materials and processes developed specifically for this line of machines. The system was chosen to provide long life at rated loads and also to withstand the effects of mechanical shock, vibration, and the contamination of many severe environments. The Class F insulation system has been proven by laboratory tests and by many years of successful operation.

TIG Welding

Low maintenance, trouble free commutator riser joints are provided by TIG (Tungsten Inert Gas) welding commutator risers to the armature coil.

This strong copper-to-copper connection eliminates the use of material with low melting temperatures and greatly increases the motor's ability to withstand overloads.

Other benefits of TIG welding include excellent mechanical strength and overload capacity, no tin or lead contaminants, and no throwing of solder.

Motor Finish

Our standard motor or generator paint is a machine tool ANSI #49 grey, heavy duty acrylic enamel over a water based primer. Polyurethane paint is available for waterproof motors.

TREC® Field Coils

Tape Reinforced Encapsulated Construction (TREC) of main field coils and commutating field coils is a process which strengthens, seals, and bonds the coil to the pole to form a single unit that is highly resistant to contamination, vibration, impact, and wear.

The TREC coil is engineered to be elastic enough to withstand expansion and contraction due to temperature differences. The TREC coil is standard on frames CD365AT-CD5010AY and CD6000-CD6900.

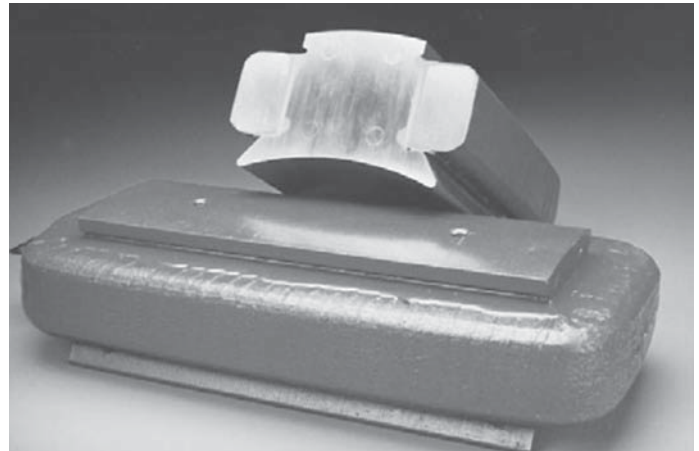

(TREC coils shown above)

Armature Treatment

Radiant Heat Process (RHP) Armatures in frames CD180AT-CD500AT are treated with a solventless polyester varnish, Radiant Heat Process. Armatures, in horizontal position, are rotated under radiant electric heaters. After preheating, the armatures are dipped and rotated under heaters to cure the varnish. This process locks the resin in place, filling the voids.

Vacuum Pressure Impregnation (VPI) Armatures in frames CD5010AY, CD6000-CD6999 are given a vacuum pressure impregnation (VPI) treatment with high temperature varnish. Armatures are placed into a vacuum vessel that pulls air from the armature. Resin is then allowed into the vessel, and pressure is applied. The pressure forces the resin into the voids. The armature is then drained and baked. Two VPI cycles ensure an even varnish coating and an excellent heat transfer path while eliminating air pockets.

Enclosures

Below is a listing of the enclosures offered by us as defined by the National Electrical Manufacturer's Association (NEMA). In addition, the International Electrotechnical Commission (IEC). Enclosure codes are shown for reference. This is a guide only. Refer to the factory for special applications or labeling requirements.

NEMA Enclosures		IEC Enclosures	
Dripproof (DP)		Protection	Cooling
DPFG	Dripproof fully guarded, self-ventilated	IP-22	IC-01
DPFG-SV	Dripproof fully guarded, separately ventilated	IP-22	IC-17
DPFG-BV	Dripproof fully guarded, blower ventilated	IP-22	IC-06
ESV	Enclosed separately ventilated, air ducted in and out	IP-44	IC-37
SPFG	Splashproof fully guarded, self-ventilated	IP-23	IC-01
SPFG-SV	Splashproof fully guarded, separately ventilated	IP-23	IC-17
SPFG-BV	Splashproof fully guarded, blower ventilated	IP-23	IC-06
Totally Enclosed (TE)		Protection	Cooling
TENV	Totally enclosed nonventilated	IP-44	IC-410
TEFC	Totally enclosed fan cooled	IP-44	IC-411
TEAO	Totally enclosed air-over-frame	IP-44	IC-416
TEAAC	Totally enclosed air-to-air cooled	IP-44	IC-666
TEWAC	Totally enclosed water-to-air cooled	IP-44	IC-86W
TENV-WP	Totally enclosed nonventilated, waterproof	IP-45/55**	IC-410
TEFC-WP	Totally enclosed fan cooled, waterproof	IP-45/55**	IC-411
TEAO-WP	Totally enclosed air-over-frame, waterproof	IP-45/55**	IC-416
Explosionproof (XP)		Protection	Cooling
TENV-XP	Totally enclosed nonventilated, explosionproof	*	*
TEFC-XP	Totally enclosed fan cooled, explosionproof	*	*
TEAO-XP	Totally enclosed air-over-frame, explosionproof	*	*

* not defined

** IP-45: Drain Holes Open

IP-55: Drain Plugs Installed (special maintenance required)

Enclosures

Dripproof, Fully Guarded

The standard Dripproof, Fully Guarded (DPFG) machine allows successful motor operation when drops of liquids or solid particles strike or enter the enclosure at any angle from 0° to 15° downward from the vertical. Openings are protected to prevent entrance of objects larger than 3/4" in diameter.

Air openings are provided for easy conversion to splashproof enclosure or for convenient connection of ducting for separate ventilation.

CD180AT frame DPFG motors mounted sidewall and vertical shaft end up will not be DPFG in that position, but will be open fully guarded (OFG).



Dripproof Fully Guarded Self-Ventilated (DPFG)

Totally Enclosed

The standard Totally Enclosed Nonventilated (TENV) or Totally Enclosed Fan Cooled (TEFC) motor provides effective protection against adverse environmental conditions. Among these conditions are dust, shavings, or other foreign materials which are not classified as hazardous gas or dust conditions. These machines are enclosed to prevent the free exchange of air between the inside and outside of the motor frame, but are not air-tight.

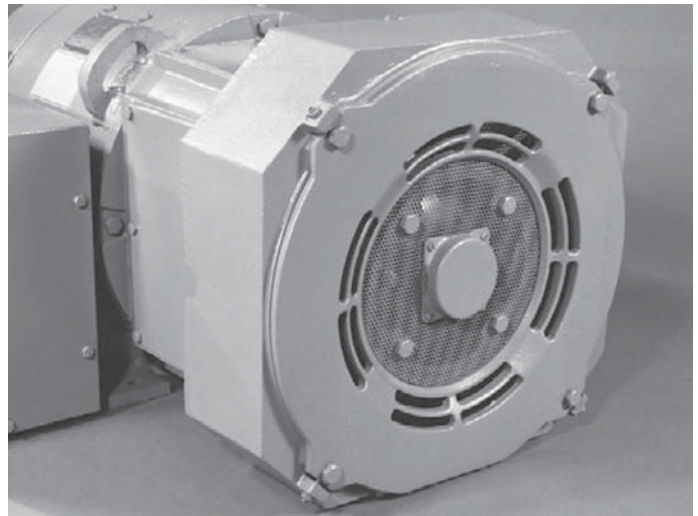

Totally Enclosed Fan Cooled (TEFC)

Explosionproof

The standard Explosionproof (XP) motor is a totally enclosed machine with a housing constructed to contain any explosion within the motor caused by the hazardous atmosphere entering the enclosure and being ignited. An explosionproof motor prevents the equipment from triggering a general fire or explosion.

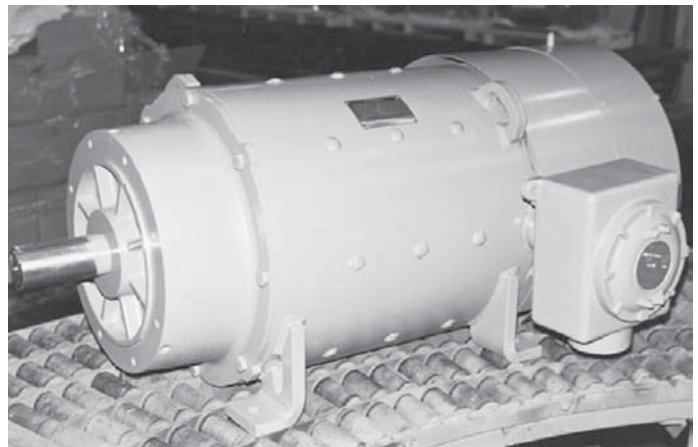

Totally Enclosed Fan Cooled Explosionproof (TEFC-XP)

Air Flow Schematics

CD180AT-CD6900 Frames

Dripproof Fully Guarded, Self-Ventilated (DPFG)

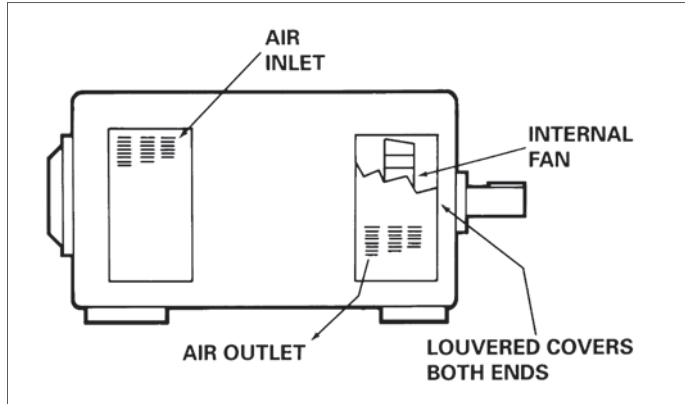

Dripproof Fully Guarded*, Blower Ventilated (DPFG-BV)

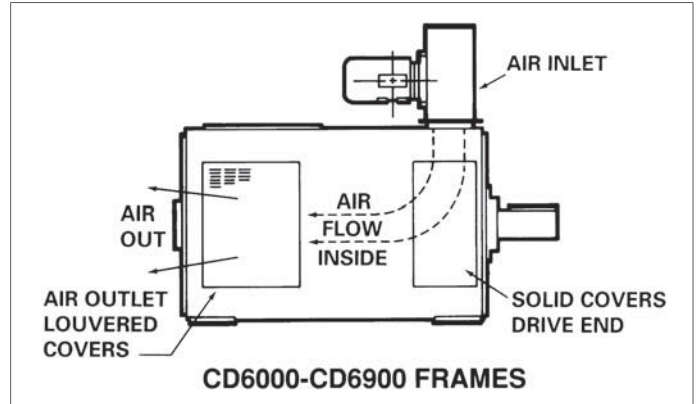

(CD218AT-CD5010AY frames have blower mounted on commutator end.)

*Could also be Splashproof Fully Guarded.

Blower positions and optional blower locations based on the position of the conduit box.

	Frame Size		
	180AT	210AT to 5010AY	CD6000 to CD6900
CB Location	Blower Locations Available		
Top	F1	CE-F1, F2	DE-F1, F2
F1	N/A	CE-F2, top	DE-F2, top
F2	N/A	CE-F1, top	DE-F1, top

NOTE: CE = comm end, DE = drive end

F1 = right side when viewed from the motor comm end, feet down

F2 = left side when viewed from the motor comm end, feet down

Dripproof Fully Guarded, Separately Ventilated (DPFG-SV)

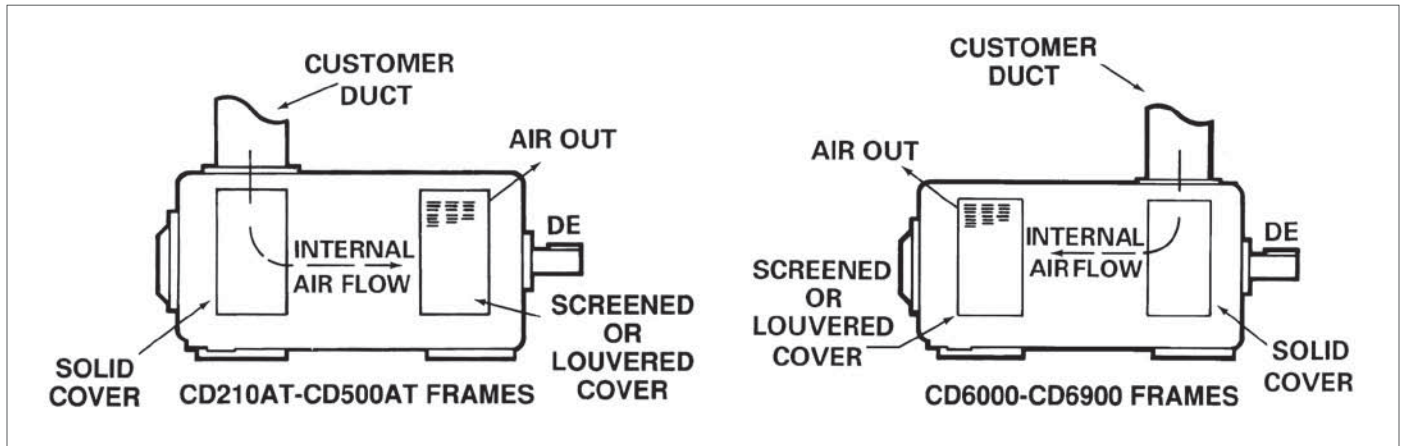

Air Flow Schematics

CD180AT-CD6900 Frames

Totally Enclosed Nonventilated (TENV)

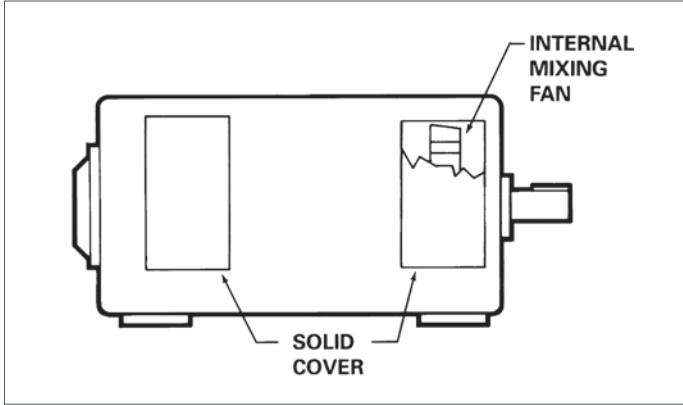

Totally Enclosed Air-Over-Frame (TEAO)

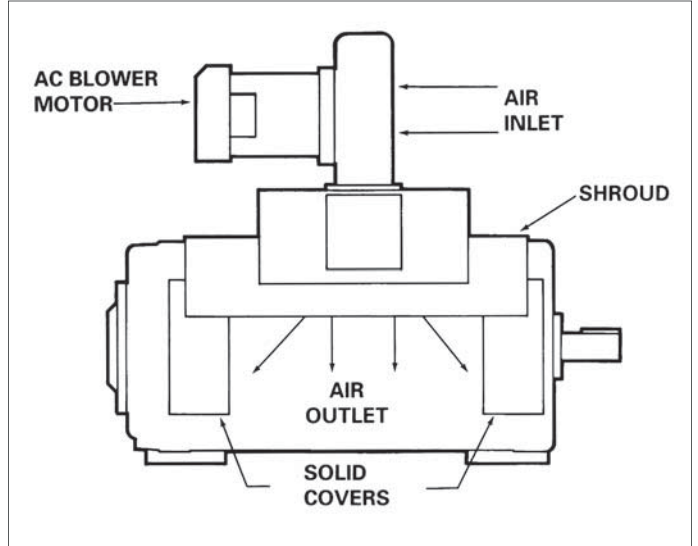

Totally Enclosed Fan Cooled (TEFC)

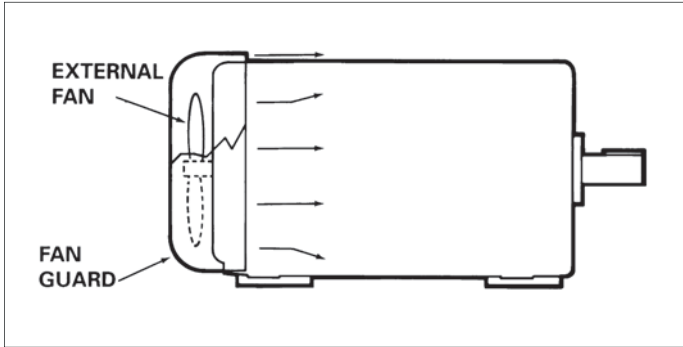

Totally Enclosed Water-to-Air Cooled (TEWAC)

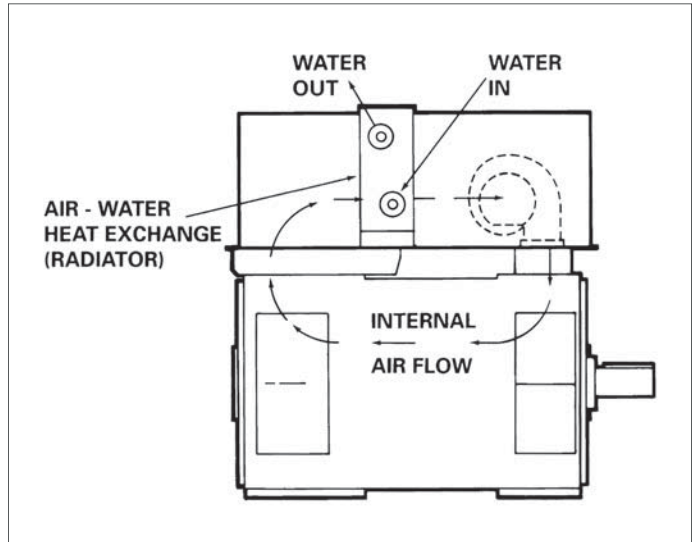

Totally Enclosed Air-to-Air Cooled (TEAAC)

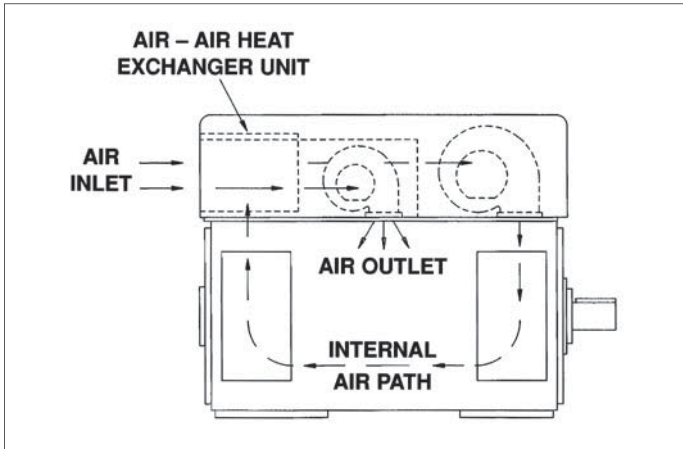

Replacement Motors

Direct Replacement

A GE DC motor with a model number which has the format, 5CDNNNLLNNLNNN, 5CDNNNLLLNNLNNN or 5BYNNNLLNNLNNN (where N=number and L=letter) will be replaced with an exact electrical/mechanical replacement of the original motor. The new motor will be supplied with the up-to-date versions of the accessories.

Non-Direct Replacement

To replace a motor which has different mounting dimensions than the Kinamatic motors shown in this publication (e.g., a motor made by a different manufacturer or an older GE motor), three options exist. When replacing a motor made by a different manufacturer, all of the information listed on the SAM-QC form (pages 1.10 and 1.11) is required for quoting and manufacturing. When replacing an older GE motor, the model and serial number of the original motor are required for quoting and manufacturing a replacement.

1. Standard Replacement

The new motor will be our standard offering (Kinamatic motor shown in this publication) which duplicated the older motor's basic rating (horsepower, armature volts, field volts, and field winding type). The new motor will not duplicate the older motor's winding characteristics (e.g., resistance, inductance, amperage, or regulation). The new motor will not duplicate the older motor's drive end shaft dimensions or frame dimensions. The new motor will not duplicate the older motor's armature inertia, overall frame height, or overall frame length. Standard Class F rise, 1.0 service factor, and NEMA standard overloads (as defined in the Accessories and Modifications section, page 3.17 item 20) will apply unless otherwise specified. The new motor will be supplied with up-to-date versions of the accessories of the older motor.

Pricing: Use standard pricing given in this publication.

2. Mechanically Interchangeable Replacement (Up-to-date replacement)

This option is available if, and only if, the shaft height of the older motor is reasonably higher (varies with motor size, but typically greater than 1 inch is sufficient) than the shaft height of the Kinamatic motor at the same rating. The new motor will be our standard offering (Kinamatic motor shown in this publication) which duplicates the older motor's basic rating (horsepower, armature volts, field volts, and field winding type). By special machining the drive end shaft,

the new motor will duplicate the older motor's mounting dimensions. (C & FC dimensions may vary from original). The new motor will not duplicate the older motor's winding characteristics (e.g., resistance, inductance, amperage, or regulation). The new motor will not duplicate the older motor's armature inertia, overall frame height, or overall frame length. Standard Class F rise, 1.0 service factor, and NEMA standard overloads (as defined in the Accessories and Modifications section, page 3.17, item 20) will apply unless otherwise specified. The new motor will be supplied with the up-to-date versions of the accessories of the older motor.

Pricing: Use standard pricing given in this publication, plus add for special shaft dimensions (page 3.19, item 24) and a transition base (page 3.3, item 6).

3. Dimensional Duplicate (Obsolete duplicate)

This option applies only to older GE motors and is only required when a mechanically interchangeable replacement motor is not applicable (e.g., shaft height difference does not allow for a transition base, or motor is coupled at both ends and a dimensional duplicate of the frame is required). The new motor will duplicate the older motor's basic rating (horsepower, armature volts, field volts, and field winding type). The new motor will duplicate critical dimensions of the older motor's frame and shaft(s). The new motor will be updated with current electrical features, will not necessarily duplicate the older motor's winding characteristics (e.g., resistance, inductance, amperage, or regulation). Standard Class F rise, 1.0 service factor, and NEMA standard overloads (as defined on page 3.17, item 20) will not apply unless otherwise specified. The new motor will be supplied with the up-to-date versions of the accessories of the older motor.

Pricing: Refer to Wolong for producibility and pricing.

Wolong suggests that all non-direct motor replacement orders be Print and Motor Data Approval Required. Wolong is not responsible for mechanical or electrical replacement problems encountered in the field.

Motor Cutaway

Kinamatic

Quality, Reliability and Serviceability

A NEMA Enclosures

- Dripproof, Totally Enclosed, Explosionproof
- All enclosures are customizable to fit specific application requirements

B Frames

- Round steel frames
- Bored to provide precise seating of main and commutating poles
- Precision rabbets for mounting of bearing brackets

C Bearings

- Double shielded bearings on frames CD180AT - CD2110AT
- Open ball bearings on frames CD258AT - CD5010AY
- Regreasable features with easy access alemite fittings to extend bearing life

D Armature

- Radiant Heat Process (RHP) on CD180AT - CD500AT frames
- Dip and bake process cures the varnish, preventing voids and protecting against moisture and contaminants
- Controlled glass banding stabilizes armature to withstand frequent starts, stops, and reversals
- Commutator risers TIG welded to armature coils - Eliminates hazards of tin or lead contaminants

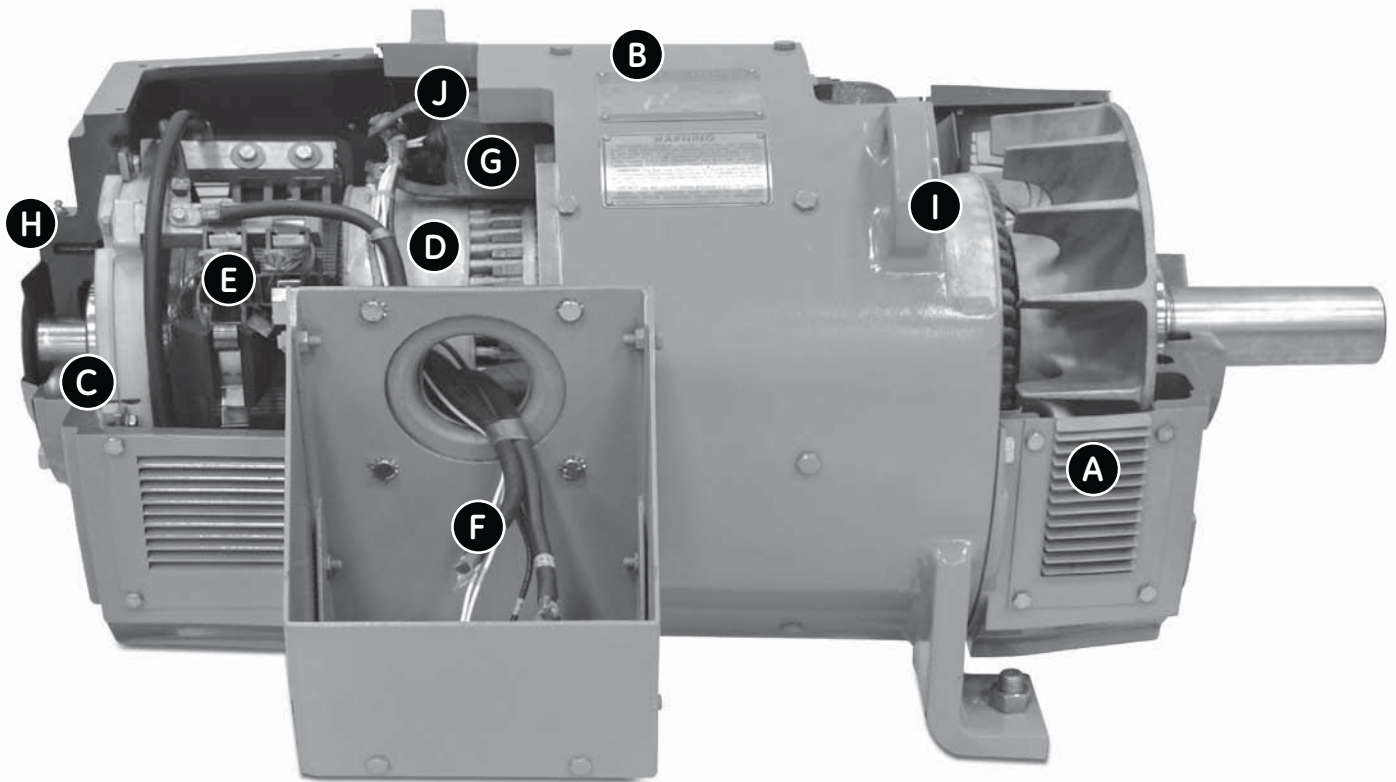

Motor Cutaway

Kinamatic

E Brush Rigging

- Field proven design that requires no adjustment
- Heavy cast brush holders with quick release brush springs provide for easy maintenance
- Constant pressure springs stabilize brush contact to ensure proper commutation and improve brush wear



F Conduit Box

- Easily accessible
- Oversized fabricated steel box
- Rubber gasketed mounting and clam shell
- Bronze grounding lug
- Rotatable 360° and F2 mounting capabilities make field adaptation easy in any application

G Insulation

- Class F system with Class H components
- Withstands effects of mechanical shock, vibration and contamination
- Long life at rated loads

H Accessory Mounting Face

- Commutator end C-face
- Shaft suitable for tachometer and speed limit switch
- Drilled and tapped mounting holes

I Lifting Lugs

- Welded into frame on CD210AT - CD5010AY frames
- Cast in endbell on CD180AT frame
- Lifting system is safer than a single eyebolt lifting system

J Coils

- Random Wound Coils
 - Frames CD180AT - CD329AT
 - Wrapped with Mylar* composite and fiberglass tapes
 - Dip and bake process allows varnish to penetrate the windings
- TREC* (Tape Reinforced Encapsulated Construction) Coils
 - Frames CD360AT - CD5010AY
 - Tightly seals coil to the pole, resisting outside contamination, vibration, impact and wear
 - Excellent heat transfer extends motor life
 - Engineered to withstand thermal expansion and contraction



Basic Requirement Instructions

The following form is designed to provide guidance through the minimum requirements needed to quote a DC Kinamatic or CD6000 frame motor. To ensure GE meets your specific needs, each quote must include the following information:

- A. Customer Identification Information
- B. Basic Motor Description
- C. Additional Modifications

Customer Identification Information

Section A – Identification information includes key customer details that will help establish a customer profile. This section also includes the following information that, although not necessary, may be extremely helpful in distinguishing special motor needs.

- a. Model Number
- b. Serial Number

Basic Motor Description

Section B – Basic Motor Description includes each of the following items and are essential in providing the correct motor specifications to meet the needs of customer applications. These DC motor offerings can be reviewed for both the Kinamatic and CD6000 frame motors in the “Standard Features” section on pages 2.2 and 2.3 at the beginning of the motor pricing tab.

1. Horsepower*
2. Base Speed*
3. Top Speed
4. Armature Voltage*
5. Field Voltage *
6. Type of Field*
7. Enclosure*
8. Orientation*
9. Mounting
10. Duty Cycle
11. Direction of Rotation
12. Temperature Rise
13. Ambient
14. Altitude
15. Service Factor
16. Conduit Box Location

* Information **REQUIRED** to provide a quote

Additional Modifications

Section C – Additional Selections include all accessories featured in the “Accessories and Modification” section beginning on page 3.1.

Minimum Data Check Sheet

Check features that apply, and specify descriptions as needed

SECTION A – Customer Identification Information

Customer: _____

 Project Name: _____

 Tracking Number: _____
 Date: _____
 Due Date: _____
 Quote Number: _____
 a. Model Number: _____
 b. Serial Number: _____

9. Mounting:
 C-Face Footed C-Face Footless
 D-Flange P-Base

10. Duty Cycle:
 Continuous (Standard)
 Other (Please specify: e.g 30 min, 60 min) _____

11. Direction of Rotation:
 Reversing (Standard) Clockwise Counter Clockwise

12. Temperature Rise:
 Class F Class B

SECTION B – Basic Motor Description

1. Horsepower*: _____
 2. Base Speed*: _____
 3. Top Speed*: _____
 4. Armature Voltage*:
 180 240 500 600 750
 _____ Volts

5. Field Voltage*:
 100/200 120/240 150/300
 _____ Volts

6. Type of Field*:
 Shunt Wound (Standard) Stabilized Shunt
 Series Compound

7. Enclosure*:
 DPGF – Dripproof Fully Guarded
 DPGF-BV – Dripproof Fully Guarded Blower Ventilated
 DPGF-SV – Dripproof Fully Guarded Self-Ventilated
 TENV – Totally Enclosed Nonventilated
 TEFC – Totally Enclosed Fan Cooled
 TEWAC – Totally Enclosed Water-to-Air Cooled
 TEAAC – Totally Enclosed Air-to-Air Cooled
 TEAO – Totally Enclosed Air-Over-Frame
 TENV-XP – Totally Enclosed Nonventilated, Explosionproof
 TEFC-XP – Totally Enclosed Fan Cooled, Explosionproof

8. Orientation*:
 Horizontal (Standard) Vertical
 Shaft Up Shaft Down

13. Ambient:
 40°C (Standard) Other _____

14. Altitude:
 3300 Ft (Standard) Other _____

15. Service Factor:
 1.0 (Standard) Other _____

16. Conduit Box:
 Location: _____
 Other _____
 F1-RHS from CE (Standard)

SECTION C – Additional Modifications

Modifications can be found on page 3.1 in section 3 of this catalog. Refer to GE with any additional specializations.

List all additional modifications/accessories below, with details regarding dimensions, size, requirements and etc.:

* Information **REQUIRED** to provide a quote

Pump Motors

CD180AT through CD6900 Frames

DESCRIPTION – Pump Motors

DC Motors with armature voltages from 105-130 Volts in most cases are used in pump applications. These are special motors built to pump manufacturer specifications. Because of the low armature voltage these motors have special electrical designs and in many cases frame sizes are larger than standard. If a model number is not available, a request for motors in this voltage range must be accompanied by the following information.

Pump motors operated from DC potential busses or batteries will show significant speed variations from nominal when the motor is cold and when the applied voltage varies below nominal.

Typically Motor RPM will be lower than nameplate speed (approximately 10-15%) when cold and increase to nameplate RPM as main field reaches operating temperature. To reduce the cold to hot speed variations, the shunt fields should be energized at 50 to 70% of rated voltage to stabilize. However, for 'emergency' pump motor applications, where field pre-heating may not be feasible, the pump capacity must be sized to the cold start RPM.

Also at lower than nominal voltage the motor will run slower than nameplate RPM, while conversely the motor will run higher than nameplate RPM when voltage is higher than nominal.

PUMP FORM

Where Used: _____	Max. Ambient Temp. _____ °C
Customer: _____	Altitude _____ Feet (Standard is 3300 feet)
Horsepower: _____ Base Speed: _____	Temperature Rise: <input type="checkbox"/> Class F <input type="checkbox"/> Class B
Enclosure: <input type="checkbox"/> DPGF <input type="checkbox"/> TENV <input type="checkbox"/> TEFC <input type="checkbox"/> Explosionproof <input type="checkbox"/> Waterproof	Service Factor: <input type="checkbox"/> 1.0 <input type="checkbox"/> 1.15
Duty: <input type="checkbox"/> Cont. <input type="checkbox"/> 60 Min. <input type="checkbox"/> 30 Min.	Rotation: <input type="checkbox"/> CW <input type="checkbox"/> CCW <input type="checkbox"/> Reversing
Power Supply: <input type="checkbox"/> Battery <input type="checkbox"/> Constant Voltage	Space Heater: Heater Voltage <input type="checkbox"/> 120V <input type="checkbox"/> 240V <input type="checkbox"/> Other _____
Armature Voltage: _____ Volts	Thermostat: <input type="checkbox"/> N.C. <input type="checkbox"/> N.O. <input type="checkbox"/> None
Field Voltage: _____ Volts	Conduit Box: <input type="checkbox"/> Standard <input type="checkbox"/> Oversize <input type="checkbox"/> Waterproof
If Battery Supply: Anticipated Voltage Swing From Nominal +/- What %? _____	Conduit Box Location: (as viewed from comm end of motor) <input type="checkbox"/> Right Side <input type="checkbox"/> Left Side <input type="checkbox"/> Top
Minimum Cold Running Speed and Voltage _____ RPM _____ Voltage	Mounting: <input type="checkbox"/> Vertical Shaft Up <input type="checkbox"/> Vertical Shaft Down <input type="checkbox"/> Horizontal
Field Winding: <input type="checkbox"/> Shunt <input type="checkbox"/> Compound <input type="checkbox"/> Stabilized Shunt	Mounting Flange (If required) <input type="checkbox"/> C-Face <input type="checkbox"/> D-Flange <input type="checkbox"/> P-Base

Drawings must be supplied for P-Base

Motor Pricing

Index

	Page
Kinamatic™ Standard Features	2.2
CD6000 Standard Features	2.3
180 Volt Motors, Self-Ventilated	2.4
180 Volt Motors, Totally Enclosed	2.5
240 and 500 Volt Motors, Self-Ventilated, 1 HP-7.5 HP	2.6
240 and 500 Volt Motors, Separately Ventilated, 1 HP-7.5 HP	2.7
240 and 500 Volt Motors, Self- and Separately Ventilated	2.8
500 Volt Motors, Separately Ventilated.	2.11
600 Volt Motors, Separately Ventilated.	2.12
600 and 700 Volt Motors, Separately Ventilated	2.13
Totally Enclosed Nonventilated Motors.	2.14
Totally Enclosed Motors	2.15
Totally Enclosed Motors, Unit Cooled	2.16
Totally Enclosed Nonventilated, 30 Minute Motors.	2.21
Totally Enclosed Nonventilated, 60 Minute Motors.	2.22
Explosionproof and Dust-Ignitionproof Motors	2.23
Papermill Duty Features.	2.26
Papermill Duty, Totally Enclosed Nonventilated	2.26
Papermill Duty, Splashproof Separately Ventilated	2.27
Power Supplies	2.29

Motor Pricing

Direct Current Motors Kinamatic™

Standard Features



Motor Pricing

HP Range	1-500
Base Speed	300-3500 RPM
Armature Voltage	240V, 500V
Field Voltage	300/150V, 240/120V
Accessory Mounting	8.5" accessory mounting rabbet with accessory shaft extension
Agency Approvals	CSA
Altitude	3300 ft
Ambient	40°C
Balance/Vibration	Measured at top speed: Peak-to-Peak Amplitude 0.0015"
Bearing Caps	Cast iron CD258AT-CD5010AY both DE and CE
Bearing Type	Anti-friction ball, CDL182AT-CD2010AT: double shielded, CD258AT-CD5010AY: open
Coils	CD180AT-CD329AT random wound- dip and baked
	CD360AT-CD5010AY TREC® Coils
Conduit Box	Fabricated steel, 360° rotatable, gasketed, oversized
Current Overload	Occasionally repeated loads of 150% of base speed full load current
Endbells	CD182AT-CD500AT: cast iron, CD5010AY: CE - cast iron, DE - fabricated steel
Frame Material	Rolled Steel
Frame Size	CD182AT-CD5010AY
Grease	Lithium soap base
Ground	Bronze bolt in conduit box
Insulation Class	Class F
Insulation System	Armature Treatment: Radiant Heat Process (RHP)
Lifting Means	Two (2) welded lifting lugs
Mounting	F1, modifiable to F2
Nameplate	Stainless Steel
Paint	ANSI #49 grey, heavy duty industrial enamel
Relubrication	CDL182AT-CD2110AT: pre-lubricated, CD258AT-CD5010AY: zerk grease fittings
Service Factor	1.0
Temperature Rise	Class F @ rated load and rated base speed
Tests	Routine Test: Report available upon request with purchase order
Warranty	24 months from date of installation or 30 months from date of manufacture; whichever occurs first

Direct Current Motors CD6000

Standard Features



HP Range	500-3000
Base Speed	300-1750 RPM
Armature Voltage	500V, 600V, 700V
Field Voltage	300/150V
Accessory Mounting	8.5" accessory mounting rabbet with accessory shaft extension
Agency Approvals	CSA
Altitude	3300 ft
Ambient	40°C
Balance/Vibration	Measured at top speed: Peak to Peak Amplitude .0020"
Bearing Caps	Cast iron - both DE and CE
Bearing Type	Anti-friction ball bearings, open
Coils	TREC® Coils
Conduit Box	Large fabricated sheet metal construction with fixed buss-bar termination
Current Overload	Occasionally repeated loads of 150% of base speed full load current
Endbells	Fabricated Steel
Frame Material	Fabricated Steel
Frame Size	CD6000-CD6900
Grease	Lithium soap base
Ground	External mounting provision
Insulation Class	Class F
Insulation System	Armature treatment: VPI (vacuum pressure impregnation)
Lifting Means	Four (4) welded lifting lugs
Mounting	F1 modifiable to F2
Nameplate	Stainless Steel
Paint	ANSI #49 Grey heavy duty industrial enamel
Relubrication	Zerk grease fittings
Service Factor	1.0
Temperature Rise	Class F @ rated load and rated base speed
Tests	Routine Test: Report available upon request with purchase order
Warranty	12 months of operation / 18 months from date of manufacture; whichever occurs first

Dripproof Fully Guarded Motors

Self-Ventilated

Class F Insulation

Type K Power Supply[®]

For Continuous Operation in 40°C Ambient

Type CD

Shunt Wound

Motor Pricing

PRICES - 180 Volts

Suitable for constant torque to 60% of base speed

HP	Base Speed RPM	Rated Top Speed RPM	Basic List Price* GO-2A	Enclosure ③	Frame ④	Dim. Pg.
1	1750	2050	\$4884	DP	L182AT ⑤ •	4.3
	1150	1380	\$5472	DP	L182AT	4.2
1.5	2500	2750	\$4798	DP	L182AT	4.2
	1750	2050	\$5108	DP	L182AT ⑤ •	4.3
	1150	1380	\$5874	DP	186AT	4.2
2	2500	2750	\$4890	DP	L182AT	4.2
	1750	2050	\$5330	DP	L182AT ⑤ •	4.3
	1150	1380	\$6342	DP	186AT	4.2
3	2500	2750	\$4540	DP	L182AT	4.2
	1750	2050	\$5166	DP	186AT ⑥	4.4
	1150	1380	\$6766	DP	L186AT	4.2
5	2500	2750	\$5146	DP	186AT	4.2
	1750	2050	\$5360	DP	L182AT ⑥ •	4.4
	1150	1380	\$7778	DP	218AT	4.10
7.5	1750	2050	\$8580	DP	219AT	4.10

PRICES - 180 Volts

Suitable for constant torque to 5% of base speed

HP	Base Speed RPM	Rated Top Speed RPM	Basic List Price* GO-2A	Enclosure ③	Frame ④	Dim. Pg.
1	1750	2050	\$4886	DP	L182AT ⑤ •	4.3
1.5	2500	2750	\$4798	DP	L182AT	4.2
	1750	2050	\$4934	DP	186AT ⑤ •	4.3
2	2500	2750	\$5134	DP	186AT	4.2
	1750	2050	\$4934	DP	186AT ⑤ •	4.3
3	2500	2750	\$5134	DP	186AT	4.2
	1750	2050	\$5374	DP	L186AT ⑥ •	4.4
5	2500	2750	\$5420	DP	189AT	4.2
	1750	2050	\$8580	DP	219AT ⑥ •	4.11

* Basic list price applies to frames listed. It does not include pricing for modifications or accessories. Refer to Modifications section for appropriate list price addition(s).

• Standard rating

② For suitability of operation with rectified power supplies, see page 2.29.

③ NV- Totally Enclosed Nonventilated

FC- Totally Enclosed Fan Cooled

DP- Dripproof Fully Guarded (Self-Ventilated).

④ Standard shaft for frames CDL182AT-CD5010AY, CD6000, and CD6100 is suitable for belt drive or direct coupling (within limits given in Application Section). Frames CD6200, CD6700, CD6800, and CD6900 are suitable for direct drive only.

⑤ Stocked with 4.5" rabbet. Shaft diameter .875".

⑥ Stocked with 8.5" rabbet. Shaft diameter 1.25".

⑦ Stocked with 4.5" and 8.5" rabbet.

⑩ Refer to Wolong for frame.

FACE MODIFICATION NOT INCLUDED IN BASIC LIST PRICE.

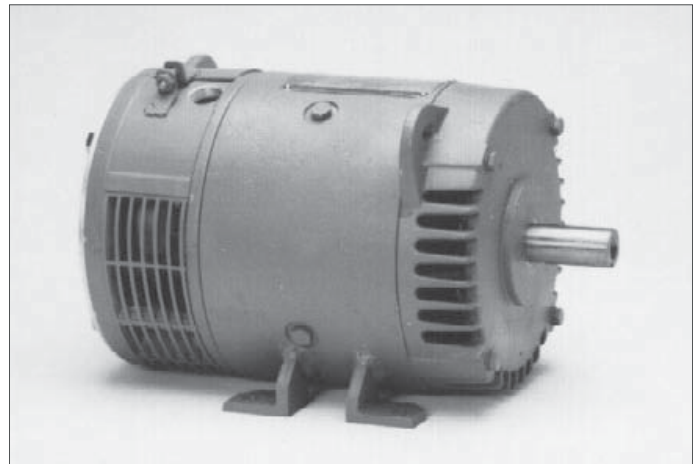

Dripproof Fully Guarded Self-Ventilated (DPFG)
(Frame CDL182AT shown above.)

Totally Enclosed Motors

Totally Enclosed

Class F Insulation

Type K Power Supply^②

For Continuous Operation in 40°C Ambient

Type CD
Shunt Wound

For explosionproof motors, refer to page 2.23.

PRICES - 180 Volts

Suitable for constant torque to 60% of base speed

HP	Base Speed RPM	Rated Top Speed RPM	Basic List Price* GO-2A	Enclosure ③	Frame ④	Dim. Pg.
3	1150	1380	\$6990	FC	189AT	4.6
	2500	2750	\$6110	FC	189AT	4.6
5	1750	2050	\$7108	FC	189AT ⑥ •	4.8

* Basic list price applies to frames listed. It does not include pricing for modifications or accessories. Refer to Modifications section for appropriate list price addition(s).

• Standard rating

② For suitability of operation with rectified power supplies, see page 2.29.

③ NV- Totally Enclosed Nonventilated

FC- Totally Enclosed Fan Cooled

DP- Drip-proof Fully Guarded (Self-Ventilated).

④ Standard shaft for frames CDL182AT-CD5010AY, CD6000, and CD6100 is suitable for belt drive or direct coupling (within limits given in Application Section). Frames CD6200, CD6700, CD6800, and CD6900 are suitable for direct drive only.

⑥ Stocked with 8.5" rabbet. Shaft diameter 1.25".

⑦ Stocked with 4.5" and 8.5" rabbet.

⑩ Refer to Wolong for frame.

FACE MODIFICATION NOT INCLUDED IN BASIC LIST PRICE.

PRICES - 180 Volts

Suitable for constant torque to 5% of base speed

HP	Base Speed RPM	Rated Top Speed RPM	Basic List Price* GO-2A	Enclosure ③	Frame ④	Dim. Pg.
1	1750	2050	\$4816	NV	L182AT ⑦ •	4.3, 4.4
	1150	1380	\$5150	NV	186AT	4.2
1.5	2500	2750	\$4886	NV	186AT	4.2
	1750	2050	\$5086	NV	186AT ⑦ •	4.3, 4.4
2	1150	1380	\$6046	NV	L186AT	4.2
	2500	2750	\$4984	NV	186AT	4.2
3	1750	2050	\$5232	NV	L186AT ⑦ •	4.3, 4.4
	1150	1380	\$5418	NV	189AT	4.2
5	2500	2750	\$5646	NV	L186AT	4.2
	1750	2050	\$5506	NV	189AT ⑦ •	4.3, 4.4
7.5	1150	1380	\$5128	NV	2110AT	4.10
	2500	2750	\$7812	NV	2110AT	4.10
7.5	1750	2050	\$10182	NV	2110AT ⑥ •	4.11
	3500	3500	\$11284	NV	258AT	4.10

Motor Pricing

Dripproof Fully Guarded Motors

Self-Ventilated

Class F Insulation

Type C Power Supply[®]

For Continuous Operation in 40°C Ambient

Type CD

Shunt Wound

240 Volt Armature - 150/300V or 120/240V Field

Suitable for constant torque to 60% of base speed

500 Volt Armature - 150/300V or 120/240V Field

Suitable for constant torque to 60% of base speed

Motor Pricing

HP	Base Speed RPM	Rated Top Speed RPM	Basic List Price* GO-2A	Frame ④	Dim. Pg.
1	1750	2300	\$2198	L182AT	4.2
	1150	2000	\$2476	L182AT	4.2
	850	1750	\$3202	186AT	4.2
1.5	3500	3500	\$1972	L182AT	4.2
	2500	3000	\$2222	L182AT	4.2
	1750	2300	\$2468	L182AT	4.2
	1150	2000	\$2882	186AT	4.2
	850	1700	\$4300	186AT	4.2
2	3500	3500	\$2170	L182AT	4.2
	2500	3000	\$2414	L182AT	4.2
	1750	2300	\$3290	L182AT •	4.2
	1500	2100	\$3066	⑩	
	1150	2000	\$3346	186AT	4.2
	850	1700	\$4848	L186AT	4.2
3	3500	3500	\$2466	L182AT	4.2
	2500	3000	\$2788	L182AT	4.2
	1750	2300	\$3938	186AT •	4.2
	1500	2100	\$4126	⑩	
	1150	2000	\$4740	L186AT	4.2
	850	1700	\$5778	218AT	4.10
	650	1600	\$6820	2110AT	4.10
	500	1500	\$8224	259AT	4.10
	400	1200	\$10632	287AT	4.10
300	900	\$12578	327AT	4.10	
5	3500	3500	\$3214	186AT	4.2
	2500	3000	\$3772	186AT	4.2
	1750	2300	\$4914	L186AT •	4.2
	1500	2100	\$5300	⑩	
	1150	2000	\$6064	218AT	4.10
	850	1700	\$7264	2110AT	4.10
	650	1600	\$8746	259AT	4.10
	500	1500	\$11444	288AT	4.10
	400	1200	\$13826	327AT	4.10
300	900	\$20212	365AT	4.15	
7.5	3500	3500	\$4336	186AT	4.2
	2500	3000	\$5032	L186AT	4.2
	1750	2300	\$5994	218AT •	4.10
	1500	2100	\$6464	⑩	
	1150	2000	\$7318	258AT	4.10
	850	1700	\$8682	259AT	4.10
	650	1600	\$11550	288AT	4.10
	500	1500	\$13810	327AT	4.10
	400	1200	\$16926	365AT	4.15
300	900	\$20212	368AT	4.15	

HP	Base Speed RPM	Rated Top Speed RPM	Basic List Price* GO-2A	Frame ④	Dim. Pg.
1	1750	2300	\$2972	L182AT	4.2
	1150	2000	\$3250	L182AT	4.2
	850	1750	\$3656	186AT	4.2
1.5	3500	3500	\$1972	L182AT	4.2
	2500	3000	\$2222	L182AT	4.2
	1750	2300	\$3242	L182AT	4.2
	1150	2000	\$3580	186AT	4.2
	850	1700	\$5022	186AT	4.2
2	3500	3500	\$2170	L182AT	4.2
	2500	3000	\$3188	L182AT	4.2
	1750	2300	\$3500	L182AT	4.2
	1500	2100	\$3066	⑩	4.2
	1150	2000	\$3580	186AT	4.2
	850	1700	\$5308	L186AT	4.2
3	3500	3500	\$2466	L182AT	4.2
	2500	3000	\$3538	L182AT	4.2
	1750	2300	\$3938	186AT •	4.2
	1500	2100	\$4126	⑩	
	1150	2000	\$5200	L186AT	4.2
	850	1700	\$5778	218AT	4.10
	650	1600	\$6820	2110AT	4.10
	500	1500	\$8224	259AT	4.10
	400	1200	\$10632	287AT	4.10
300	900	\$12578	327AT	4.10	
5	3500	3500	\$3214	186AT	4.2
	2500	3000	\$3772	186AT	4.2
	1750	2300	\$4914	L186AT •	4.2
	1500	2100	\$5300	⑩	
	1150	2000	\$6064	218AT	4.10
	850	1700	\$7264	2110AT	4.10
	650	1600	\$8746	259AT	4.10
	500	1500	\$11444	288AT	4.10
	400	1200	\$13826	327AT	4.10
300	900	\$20212	365AT	4.15	
7.5	3500	3500	\$4336	186AT	4.2
	2500	3000	\$5032	L186AT	4.2
	1750	2300	\$5994	218AT •	4.10
	1500	2100	\$6464	⑩	
	1150	2000	\$7318	258AT	4.10
	850	1700	\$8682	259AT	4.10
	650	1600	\$11550	288AT	4.10
	500	1500	\$13810	327AT	4.10
	400	1200	\$16926	365AT	4.15
300	900	\$20212	368AT	4.15	

* Basic list price applies to frames listed. It does not include pricing for modifications or accessories. Refer to Modifications section for appropriate list price addition(s).

• Standard rating

® For suitability of operation with rectified power supplies, see page 2.29.

④ Standard shaft for frames CDL182AT-CD5010AY, CD6000, and CD6100 is suitable for belt drive or direct coupling (within limits given in Application Section). Frames CD6200, CD6700, CD6800, and CD6900 are suitable for direct drive only.

⑩ Refer to Wolong for frame.

Dripproof Fully Guarded Motors

Separately Ventilated

Class F Insulation

Type C Power Supply[Ⓜ]

For Continuous Operation in 40°C Ambient

Type CD

Shunt Wound

240 Volt Armature - 150/300V or 120/240V Field

Suitable for constant torque to 5% of base speed

500 Volt Armature - 150/300V or 120/240V Field

Suitable for constant torque to 5% of base speed

HP	Base Speed RPM	Rated Top Speed RPM	Basic List Price* GO-2A	Frame ④	Dim. Pg.
1	1750	2300	\$2198	L182AT	4.2
	1150	2000	\$2476	L182AT	4.2
	850	1750	\$3202	186AT	4.2
1.5	3500	3500	\$1972	L182AT	4.2
	2500	3000	\$2222	L182AT	4.2
	1750	2300	\$2468	L182AT	4.2
	1150	2000	\$2882	186AT	4.2
	850	1700	⑩	⑩	
2	2500	3000	\$2414	L182AT	4.2
	1750	2300	\$2726	L182AT	4.2
	1150	2000	\$3346	186AT	4.2
	850	1700	\$4848	L186AT	4.2
3	3500	3500	\$2466	L182AT	4.2
	2500	3000	\$2788	L182AT	4.2
	1750	2300	\$3304	186AT	4.2
	1150	2000	\$4740	L186AT	4.2
	850	1700	\$5778	218AT	4.10
	650	1600	\$6820	2110AT	4.10
	500	1500	\$8224	259AT	4.10
	400	1200	\$9666	287AT	4.10
5	3500	3500	\$3214	186AT	4.2
	2500	3000	\$3772	186AT	4.2
	1750	2300	\$4914	L186AT	4.2
	1500	2100	\$5300	⑩	
	1150	2000	\$6064	218AT	4.10
	850	1700	\$7264	2110AT	4.10
	650	1600	\$8746	259AT	4.10
	500	1500	\$10404	288AT	4.10
	400	1200	\$12570	327AT	4.10
7.5	3500	3500	\$4336	186AT	4.2
	2500	3000	\$5032	L186AT	4.2
	1750	2300	\$5994	189AT	4.2
	1500	2100	\$6464	⑩	
	1150	2000	\$7318	2110AT	4.10
	850	1700	\$8682	259AT	4.10
	650	1600	\$10500	288AT	4.10
	500	1500	\$12556	327AT	4.10
	400	1200	\$15388	328AT	4.10
300	900	\$18376	329AT	4.10	

HP	Base Speed RPM	Rated Top Speed RPM	Basic List Price* GO-2A	Frame ④	Dim. Pg.
1	1750	2300	\$2972	186AT	4.2
	1150	2000	⑩	⑩	
	850	1750	⑩	⑩	
1.5	3500	3500	⑩	⑩	
	2500	3000	⑩	⑩	
	1750	2300	\$3242	186AT	4.2
	1150	2000	\$3580	⑩	
	850	1700	⑩	⑩	
2	2500	3000	\$3188	186AT	4.2
	1750	2300	\$3500	186AT	4.2
	1500	2100	\$3066	L186AT	4.2
	1150	2000	\$3580	L186AT	4.2
	850	1700	\$4848	⑩	
3	3500	3500	\$2466	⑩	
	2500	3000	\$3538	186AT	4.2
	1750	2300	\$3938	186AT	4.2
	1500	2100	\$4126	L186AT	4.2
	1150	2000	\$4740	L186AT	4.2
	850	1700	\$5778	218AT	4.10
	650	1600	\$6820	⑩	
	500	1500	\$8224	⑩	
	400	1200	\$9666	⑩	
5	3500	3500	\$3214	⑩	
	2500	3000	\$3772	L186AT	4.2
	1750	2300	\$4914	L186AT	4.2
	1500	2100	\$5300	218AT	4.10
	1150	2000	\$6064	219AT	4.10
	850	1700	\$7264	2110AT	4.10
	650	1600	\$8746	⑩	
	500	1500	\$10404	⑩	
	400	1200	\$12570	⑩	
7.5	3500	3500	\$4336	⑩	
	2500	3000	\$5032	⑩	
	1750	2300	\$5994	218AT	4.10
	1500	2100	\$6464	219AT	4.10
	1150	2000	\$7318	2110	4.10
	850	1700	\$8682	259AT	4.10
	650	1600	\$10500	288AT	4.10
	500	1500	\$12556	327AT	4.10
	400	1200	\$15388	328AT	4.10
300	900	\$18376	368AT	4.15	

* Basic list price applies to frames listed. It does not include pricing for modifications or accessories. Refer to Modifications section for appropriate list price addition(s).

Ⓜ For suitability of operation with rectified power supplies, see page 2.29.

④ Standard shaft for frames CDL182AT-CD5010AY, CD6000, and CD6100 is suitable for belt drive or direct coupling (within limits given in Application Section). Frames CD6200, CD6700, CD6800, and CD6900 are suitable for direct drive only.

⑩ Refer to Wolong for frame.

Motor Pricing

Dripproof Fully Guarded Motors

Class F Insulation

Type C Power Supply[Ⓜ]

For Continuous Operation in 40°C Ambient

Self-Ventilated and Separately Ventilated

Type CD

Shunt Wound

PRICES - 240 and 500 Volts

Motor Pricing

			Self Ventilated [DPFG] Suitable for constant torque to 60% of base speed				Separately Ventilated [DPFG-SV] Suitable for constant torque to 5% of base speed			
HP	Base Speed RPM	Rated Top Speed RPM	Basic List Price* GO-2A	Frame ④		Dim. Pg.	Basic List Price* GO-2A	Frame ④		Dim. Pg.
				240V	500V			240V	500V	
10	3500	3500	\$5652	218AT	⑩	4.10	\$5652	218AT	218AT	4.10
	2500	3000	\$5788	218AT	218AT	4.10	\$5788	218AT	218AT	4.10
	1750	2300	\$6874	219AT •	219AT •	4.10	\$6874	219AT	219AT	4.10
	1500	2100	\$7442	⑩	258AT	4.10	\$7442	⑩	258AT	4.10
	1150	2000	\$8358	258AT	258AT	4.10	\$8358	258AT	258AT	4.10
	850	1700	\$10988	287AT	287AT	4.10	\$9990	287AT	287AT	4.10
	650	1600	\$13514	327AT	327AT	4.10	\$12286	327AT	327AT	4.10
	500	1500	\$16004	365AT	365AT	4.15	\$14550	328AT	328AT	4.10
	400	1200	\$19706	366AT	366AT	4.15	\$17916	329AT	329AT	4.10
	300	900	\$24742	368AT	407AT	4.15	\$21516	366AT	368AT	4.15
250	750					\$24166	366AT	368AT	4.15	
15	3500	3500	\$6894	218AT	218AT	4.10	\$6894	218AT	218AT	4.10
	2500	3000	\$7020	219AT	219AT	4.10	\$7020	219AT	219AT	4.10
	1750	2300	\$8332	258AT •	258AT •	4.10	\$8332	258AT	258AT	4.10
	1500	2100	\$9078	⑩	259AT	4.10	\$9078	⑩	259AT	4.10
	1150	2000	\$11272	288AT	288AT	4.10	\$10248	288AT	288AT	4.10
	850	1700	\$13442	327AT	327AT	4.10	\$12220	327AT	327AT	4.10
	650	1600	\$16708	365AT	365AT	4.15	\$15190	327AT	327AT	4.10
	500	1500	\$20928	368AT	368AT	4.15	\$18198	328AT	329AT	4.10
	400	1200	\$25324	407AT	407AT	4.15	\$21952	366AT	365AT	4.15
	300	900	\$31092	409AT	409AT	4.15	\$27036	366AT	366AT	4.15
250	750					\$30546	368AT	409AT	4.15	
20	3500	3500	\$8178	219AT	219AT	4.10	\$8178	219AT	219AT	4.10
	2500	3000	\$8088	258AT	258AT	4.10	\$8088	258AT	258AT	4.10
	1750	2300	\$9600	259AT •	259AT •	4.10	\$9600	259AT	259AT	4.10
	1500	2100					\$10454	⑩	287AT	4.10
	1150	2000	\$13098	327AT	327AT •	4.10	\$11908	327AT	327AT •	4.10
	850	1700	\$16068	365AT	365AT	4.15	\$14608	328AT	328AT	4.10
	650	1600	\$19898	366AT	366AT	4.15	\$18090	328AT	328AT	4.10
	500	1500	\$24734	368AT	407AT	4.15	\$21508	329AT	329AT	4.10
	400	1200	\$30074	407AT	407AT	4.15	\$26152	366AT	366AT	4.15
	300	900	\$37828	504AT	508AT	4.15	\$31642	407AT	407AT	4.15
250	750					\$36496	407AT	⑩	4.15	
25	3500	3500	\$9114	258AT	258AT	4.10	\$9114	258AT	258AT	4.10
	2500	3000	\$8974	258AT	259AT	4.10	\$8974	258AT	259AT	4.10
	1750	2300	\$11926	287AT •	287AT •	4.10	\$10842	287AT	287AT	4.10
	1500	2100					\$11660	⑩	288AT	4.10
	1150	2000	\$15074	328AT	328AT	4.10	\$13704	328AT	328AT •	4.10
	850	1700	\$18340	365AT	366AT	4.15	\$16674	328AT	328AT	4.10
	650	1600	\$23832	368AT	368AT	4.15	\$20724	329AT	329AT	4.10
	500	1500	\$28350	407AT	409AT	4.15	\$24652	366AT	368AT	4.15
	400	1200	\$34374	409AT	409AT	4.15	\$29890	368AT	368AT	4.15
	300	900	\$40936	504AT	508AT	4.15	\$35596	409AT	409AT	4.15
250	750					\$41896	409AT	⑩	4.15	
30	3500	3500	\$10420	287AT	259AT	4.10	\$10420	287AT	259AT	4.10
	2500	3000	\$9864	287AT	259AT	4.10	\$9864	287AT	259AT	4.10
	1750	2300	\$13158	288AT •	288AT •	4.10	\$11962	288AT	288AT •	4.10
	1500	2100					\$13012	⑩	327AT	4.10
	1150	2000	\$16678	365AT	365AT	4.15	\$15162	328AT	328AT	4.10
	850	1700	\$20390	366AT	366AT	4.15	\$18538	329AT	329AT	4.10
	650	1600	\$26238	407AT	407AT	4.15	\$22816	366AT	366AT	4.15
	500	1500	\$31454	407AT	409AT	4.15	\$27352	368AT	407AT	4.15
	400	1200	\$37860	504AT	506AT	4.15	\$32922	407AT	407AT	4.15
	300	900	\$46276	506AT	508AT	4.15	\$40240	409AT	409AT	4.15
250	750					\$50400	409AT	⑩	4.15	

* Basic list price applies to frames listed. It does not include pricing for modifications or accessories. Refer to Modifications section for appropriate list price addition(s).

• Standard rating

Ⓜ For suitability of operation with rectified power supplies, see page 2.29.

④ Standard shaft for frames CDL182AT-CD5010AY, CD6000, and CD6100 is suitable for belt drive or direct coupling (within limits given in Application Section). Frames CD6200, CD6700, CD6800, and CD6900 are suitable for direct drive only.

⑩ Refer to Wolong for frame.

Dripproof Fully Guarded Motors

Class F Insulation

Type C Power Supply[Ⓜ]

For Continuous Operation in 40°C Ambient

Self-Ventilated and Separately Ventilated

Type CD

Shunt Wound

PRICES - 240 and 500 Volts

			Self Ventilated [DPFG] Suitable for constant torque to 60% of base speed				Separately Ventilated [DPFG-SV] Suitable for constant torque to 5% of base speed			
HP	Base Speed RPM	Rated Top Speed RPM	Basic List Price* GO-2A	Frame ④		Dim. Pg.	Basic List Price* GO-2A	Frame ④		Dim. Pg.
				240V	500V			240V	500V	
40	3500	3500	\$12004	287AT	⑩	4.10	\$12004	⑩	⑩	
	2500	3000	\$12678	287AT	288AT	4.10	\$11526	287AT	288AT	4.10
	1750	2100	\$15534	328AT	328AT •	4.10	\$14122	328AT	327AT •	4.10
	1500	2000					\$15598	327AT	328AT	4.10
	1150	2000	\$20774	366AT	366AT •	4.15	\$18064	328AT	328AT •	4.10
	850	1700	\$25386	368AT	368AT •	4.15	\$22074	366AT	366AT	4.15
	650	1600	\$31050	409AT	407AT	4.15	\$27000	368AT	368AT	4.15
	500	1500	\$37474	504AT	504AT	4.15	\$32586	409AT	407AT	4.15
	400	1200	\$44662	506AT	506AT	4.15	\$38836	407AT	409AT	4.15
300	900	\$54908	508AT	508AT	4.15	\$47746	506AT	409AT	4.15	
250	750					\$56926	506AT	⑩	4.15	
50	3500	3500					\$15300	⑩	⑩	
	2500	2700	\$15088	327AT	288AT	4.10	\$13716	327AT	288AT	4.10
	1750	2100	\$17788	365AT	328AT •	4.15, 4.10	\$16170	328AT	328AT •	4.10
	1500	2000					\$17952	328AT	329AT	4.10
	1150	2000	\$23970	368AT	368AT •	4.15	\$20844	329AT	366AT •	4.10, 4.15
	850	1700	\$29468	407AT	407AT	4.15	\$25624	368AT	368AT	4.15
	650	1600	\$35708	504AT	409AT	4.15	\$31050	407AT	407AT	4.15
	500	1500	\$42944	506AT	506AT	4.15	\$37342	409AT	504AT	4.15
	400	1200	\$51306	508AT	508AT	4.15	\$44614	506AT	409AT	4.15
300	900					\$54420	506AT	508AT	4.15	
250	750					\$65250	508AT	508AT	4.15	
60	3500	3500	\$20406	⑩	⑩		\$18550	⑩	⑩	
	2500	2700	\$17608	365AT	328AT	4.15, 4.10	\$16008	365AT	328AT	4.15, 4.10
	1750	2100	\$20406	366AT •	366AT •	4.15	\$18550	366AT	L328AT •	4.15, 4.10
	1500	2000					\$20138		366AT	4.15
	1150	2000	\$27434	407AT	368AT •	4.15	\$23856	368AT	368AT •	4.15
	850	1700	\$33490	L409AT	407AT	4.15	\$29122	368AT	368AT	4.15
	650	1600	\$40210	504AT	504AT	4.15	\$34966	409AT	407AT	4.15
	500	1500	\$48652	506AT	506AT	4.15	\$42306	409AT	504AT	4.15
	400	1200	\$57536	508AT	508AT	4.15	\$50032	506AT	506AT	4.15
300	900					\$60778	508AT	506AT	4.15	
250	750					\$71460	508AT	508AT	4.15	
75	3500	3500	\$24538	⑩			\$22308	⑩	⑩	
	2500	2700	\$22450	⑩	365AT	4.15	\$20410	365AT	329AT	4.15, 4.10
	1750	2100	\$24028	366AT •	366AT •	4.15	\$21844	366AT	329AT •	4.15, 4.10
	1500	2000					\$23176		366AT	4.15
	1150	2000	\$32310	L407AT	407AT	4.15	\$28096	368AT	368AT •	4.15
	850	1700	\$38482	504AT	504AT	4.15	\$33462	407AT	407AT	4.15
	350	1600	\$46966	506AT	506AT	4.15	\$40840	409AT	504AT	4.15
	500	1500	\$56104	508AT	508AT	4.15	\$48786	506AT	506AT	4.15
	400	1200					\$57480	506AT	506AT	4.15
300	900					\$71586	508AT	508AT	4.15	
250	750					\$79800	5010AY	⑩	4.15	
100	2500	2700	\$30222	⑩	366AT	4.15	\$27474	366AT	366AT	4.15
	1750	2000	\$30222	368AT	368AT •	4.15	\$27474	368AT	368AT •	4.15
	1500	2000					\$29050	⑩	368AT	4.15
	1150	2000	\$39558	L409AT	409AT	4.15	\$34398	L407AT	407AT •	4.15
	850	1700	\$46420	504AT	506AT	4.15	\$40366	L409AT	409AT	4.15
	650	1600	\$56282	508AT	508AT	4.15	\$48940	506AT	506AT	4.15
	500	1500					\$58032	506AT	508AT	4.15
	400	1200					\$70398	508AT	5010AY	4.15
	300	900					\$84600	5010AY	5010AY	4.15
250	750					\$93630	5010AY	6062	4.15, 4.29	

Motor Pricing

* Basic list price applies to frames listed. It does not include pricing for modifications or accessories. Refer to Modifications section for appropriate list price addition(s).

• Standard rating

Ⓜ For suitability of operation with rectified power supplies, see page 2.29.

④ Standard shaft for frames CDL182AT-CD5010AY, CD6000, and CD6100 is suitable for belt drive or direct coupling (within limits given in Application Section). Frames CD6200, CD6700, CD6800, and CD6900 are suitable for direct drive only.

⑩ Refer to Wolong for frame.

Dripproof Fully Guarded Motors

Class F Insulation

Type C Power Supply^②

For Continuous Operation in 40°C Ambient

Self-Ventilated and Separately Ventilated

Type CD

Shunt Wound

PRICES - 240 and 500 Volts

			Self Ventilated [DPFG] Suitable for constant torque to 60% of base speed				Separately Ventilated [DPFG-SV] Suitable for constant torque to 5% of base speed				
HP	Base Speed RPM	Rated Top Speed RPM	Basic List Price* GO-2A	Frame ④		Dim. Pg.	Basic List Price* GO-2A	Frame ④		Dim. Pg.	
				240V	500V			240V	500V		
125	2500	2700	\$35848	⑩	368AT	4.15	\$32590	L407AT	368AT	4.15	
	1750	2000	\$35848	L407AT	407AT •	4.15	\$32590	L407AT	368AT •	4.15	
	1500	2000					\$34960	⑩	407AT	4.15	
	1150	2000	\$46420		504AT	506AT	4.15	\$40366	L409AT	409AT •	4.15
	850	1700	\$54400		506AT	508AT	4.15	\$47304	504AT	506AT	4.15
	650	1600					\$56364	506AT	506AT	4.15	
	500	1500					\$69264	508AT	508AT	4.15	
	400	1200					\$80700	5010AY	5010AY	4.15	
	300	900					\$95632	5010AY	5010AY	4.15	
250	750					\$106624	6160	6062	4.30, 4.29		
150	2500	2700	\$43192	⑩	407AT	4.15	\$37558	L407AT	407AT	4.15	
	1750	2000	\$43192	L409AT	409AT	4.15	\$37558	L407AT	407AT	4.15	
	1500	2000					\$40672	⑩	409AT	4.15	
	1150	2000	\$53424		506AT	506AT	4.15	\$46456	L409AT	409AT	4.15
	850	1700	\$61590		508AT	508AT	4.15	\$53556	506AT	506AT	4.15
	650	1600					\$63466	506AT	506AT	4.15	
	500	1500					\$78234	5010AY	508AT	4.15	
	400	1200					\$88812	5010AY	5010AY	4.15	
300	900					\$106624	6062	6062	4.29		
200	1750	2000	\$54866		504AT	504AT	4.15	\$47710	L409AT	L409AT	4.15
	1500	1900					\$51640	⑩	L409AT	4.15	
	1150	1800	\$66198		L508AT	508AT	4.15	\$57564	506AT	506AT	4.15
	850	1700					\$65652	508AT	506AT	4.15	
	650	1600					\$77992	5010AY	508AT	4.15	
	500	1500					\$92718	6058	6062	4.29	
	400	1200					\$106782	6058	6157	4.29, 4.30	
300	900					\$126330	6160	6164	4.30		
250	1750	1900	\$67534		L506AT	506AT	4.15	\$58726	L504AT	504AT	4.15
	1500	1800					\$62148	⑩	506AT	4.15	
	1150	1700					\$69190	L508AT	506AT	4.15	
	850	1600					\$78130	6052	5010AY	4.29, 4.15	
	650	1600					\$88426	6058	5010AY	4.29, 4.15	
	500	1500					\$110914	6062	6062	4.29	
	400	1200					\$124290	6160	6169	4.30	
300	900					\$145464	6164	6259	4.30, 4.31		

* Basic list price applies to frames listed. It does not include pricing for modifications or accessories. Refer to Modifications section for appropriate list price addition(s).

• Standard rating

② For suitability of operation with rectified power supplies, see page 2.29.

④ Standard shaft for frames CDL182AT-CD5010AY, CD6000, and CD6100 is suitable for belt drive or direct coupling (within limits given in Application Section). Frames CD6200, CD6700, CD6800, and CD6900 are suitable for direct drive only.

⑩ Refer to Wolong for frame.

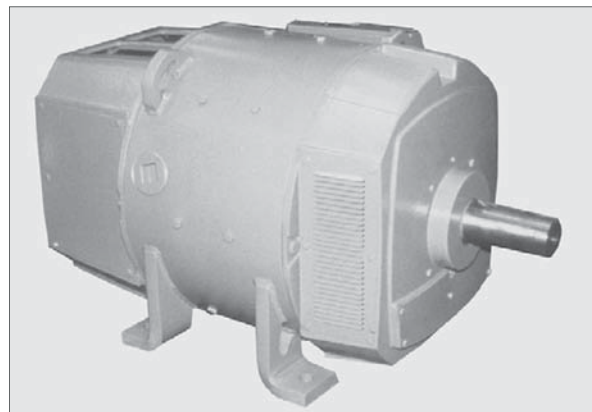

Dripproof Fully Guarded Separately-Ventilated (DPFG-SV)
(Frame CD506AT shown above.)

Dripproof Fully Guarded Motors

Separately Ventilated

Class F Insulation

Type C Power Supply[Ⓜ]

For Continuous Operation in 40°C Ambient

Type CD

Shunt Wound

PRICES - 500 Volts

			Separately Ventilated [DPFG-SV] Suitable for constant torque to 5% of base speed		
HP	Base Speed RPM	Rated Top Speed RPM	Basic List Price* GO-2A	Frame ④	Dim. Pg.
				500V	
300	1750	1900	\$70470	506AT •	4.15
	1500	1800	\$74906	506AT	4.15
	1150	1600	\$81204	508AT •	4.15
	850	1500	\$91126	5010AY •	4.15
	650	1500	\$100846	6062	4.29
	500	1300	\$121416	6160	4.30
	400	1200	\$139644	6169	4.30
400	300	900	\$163024	6262	4.31
	1750	1900	\$98010	508AT •	4.15
	1500	1800	\$104280	5010AY	4.15
	1150	1500	\$107730	5010AY •	4.15
	850	1500	\$117450	6062	4.29
	650	1400	\$126090	6160	4.30
	500	1200	\$141840	6259	4.31
500	400	1000	\$166372	6262	4.31
	300	750	\$200410	6266	4.31
	1750	1900	\$131130	5010AY •	4.15
	1500	1700	\$134786	6055	4.29
	1150	1500	\$138040	6058	4.29
	850	1400	\$146814	6160	4.30
	650	1200	\$153288	6164	4.30
600	500	1000	\$166686	6262	4.31
	400	1000	\$200544	6266	4.31
	300	750	\$228456	6271	4.31
	1750	1900	\$181576	6063	4.29
	1500	1700	\$188510	6063	4.29
	1150	1500	\$201664	6066	4.29
	850	1300	\$203616	6173	4.30
600	650	1200	\$222928	6268	4.31
	500	1000	\$248968	6275	4.31
	400	1000	\$266634	6280	4.31
	300	750	\$290842	6881	4.33

			Separately Ventilated [DPFG-SV] Suitable for constant torque to 5% of base speed		
HP	Base Speed RPM	Rated Top Speed RPM	Basic List Price* GO-2A	Frame ④	Dim. Pg.
				500V	
700	1750	1800	\$206786	6165	4.30
	1500	1700	\$216564	⑩	
	1150	1300	\$224164	6168	4.30
	850	1200	\$226248	6173	4.30
	650	1000	\$251260	6270	4.31
	500	1000	\$273780	6275	4.31
	400	1000	\$291438	6881	4.33
800	300	750	\$326238	6887	4.33
	1750	1750	\$242216	⑩	
	1150	1250	\$247248	6173	4.30
	850	1000	\$249630	6270	4.31
	650	1000	\$275346	6275	4.31
	500	1000	\$296988	6280	4.31
	400	1000	\$317656	6881	4.33
900	300	750	\$355582	6887	4.33
	1150	1250	\$276126	6268	4.31
	850	1000	\$278298	6270	4.31
	650	1000	\$298690	6275	4.31
	500	1000	\$318642	6779	4.32
	400	1000	\$339120	6887	4.33
	300	750	\$379612	6985	4.34
1000	1150	1250	\$299808	6268	4.31
	850	1000	\$301686	6270	4.31
	650	1000	\$320878	6774	4.32
	500	1000	\$342954	6881	4.33
	400	1000	\$363186	6887	4.33
	300	750	\$406548	6985	4.34
1250	250	710	\$462600	6991	4.34
	1150	1150	\$358344	6776	4.32
	850	1000	\$360222	6778	4.32
	650	1000	\$379944	6785	4.32
	500	1000	\$399922	6896	4.33
	400	900	\$423514	6996	4.34
300	750	\$474082	⑩		

Motor Pricing

* Basic list price applies to frames listed. It does not include pricing for modifications or accessories. Refer to Modifications section for appropriate list price addition(s).

• Standard rating

Ⓜ For suitability of operation with rectified power supplies, see page 2.29.

④ Standard shaft for frames CDL182AT-CD5010AY, CD6000, and CD6100 is suitable for belt drive or direct coupling (within limits given in Application Section). Frames CD6200, CD6700, CD6800, and CD6900 are suitable for direct drive only.

⑩ Refer to Wolong for frame.

Dripproof Fully Guarded Motors

Class F Insulation

Type C Power Supply[Ⓜ]

For Continuous Operation in 40°C Ambient

Separately Ventilated

Type CD
Shunt Wound

PRICES - 600V

Motor Pricing

			Separately Ventilated [DPFG-SV] Suitable for constant torque to 5% of base speed		
HP	Base Speed RPM	Rated Top Speed RPM	Basic List Price* GO-2A	Frame ④	Dim. Pg.
				600V	
25	1750	1750	\$10842	287AT	4.10
	1150	1150	\$13704	327AT	4.10
	850	850	\$16674	328AT	4.10
	650	650	\$20724	Ⓣ	
	500	500	\$24652	Ⓣ	
400	400	\$29890	Ⓣ		
30	1750	1750	\$11962	288AT	4.10
	1150	1150	\$15162	328AT	4.10
	850	850	\$18538	329AT	4.10
	650	650	\$22816	Ⓣ	
	500	500	\$27352	Ⓣ	
400	400	\$32922	Ⓣ		
40	1750	1750	\$14122	327AT	4.10
	1150	1150	\$18064	329AT	4.10
	850	850	\$22074	368AT	4.15
	650	650	\$27000	Ⓣ	
	500	500	\$32586	Ⓣ	
400	400	\$38836	Ⓣ		
50	1750	1750	\$16170	328AT	4.10
	1150	1150	\$20844	329AT	4.10
	850	850	\$25624	368AT	4.15
	650	650	\$31050	Ⓣ	
	500	500	\$37342	Ⓣ	
400	400	\$44614	Ⓣ		
60	1750	1750	\$18550	L328AT	4.10
	1150	1150	\$23856	368AT	4.15
	850	850	\$29122	407AT	4.15
	650	650	\$34966	Ⓣ	
	500	500	\$42306	Ⓣ	
400	400	\$50032	Ⓣ		
75	1750	1750	\$21844	329AT	4.10
	1150	1150	\$28096	368AT	4.15
	850	850	\$33462	409AT	4.15
	650	650	\$40840	Ⓣ	
	500	500	\$48786	Ⓣ	
400	400	\$57480	Ⓣ		

			Separately Ventilated [DPFG-SV] Suitable for constant torque to 5% of base speed		
HP	Base Speed RPM	Rated Top Speed RPM	Basic List Price* GO-2A	Frame ④	Dim. Pg.
				600V	
100	1750	1750	\$27474	368AT	4.15
	1150	1150	\$34398	407AT	4.15
	850	850	\$40366	409AT	4.15
	650	650	\$48940	Ⓣ	
	500	500	\$58032	Ⓣ	
400	400	\$70398	Ⓣ		
125	1750	1750	\$32590	407AT	4.15
	1150	1150	\$40366	409AT	4.15
	850	850	\$47304	506AT	4.15
	650	650	\$56364	Ⓣ	
	500	500	\$69264	Ⓣ	
400	400	\$80700	Ⓣ		
150	1750	1750	\$37558	409AT	4.15
	1150	1150	\$46456	409AT	4.15
	850	850	\$53556	506AT	4.15
	650	650	\$63466	Ⓣ	
	500	500	\$78234	Ⓣ	
400	400	\$88812	Ⓣ		
200	1750	1750	\$47710	409AT	4.15
	1150	1150	\$57564	506AT	4.15
	850	850	\$65652	508AT	4.15
	650	650	\$77992	Ⓣ	
	500	500	\$92718	Ⓣ	
400	400	\$106782	6062	4.29	
250	1750	1750	\$58726	504AT	4.15
	1150	1150	\$69190	508AT	4.15
	850	850	\$78130	5010AY	4.15
	650	650	\$88426	Ⓣ	
	500	500	\$110914	6062	4.29
400	400	\$124290	6160	4.30	
300	1750	1750	\$70470	506AT	4.15
	1150	1150	\$81204	5010AY	4.15
	850	850	\$91126	Ⓣ	
	650	650	\$100846	6062	4.29
	500	500	\$121416	6160	4.30
400	400	\$139644	6164	4.30	

* Basic list price applies to frames listed. It does not include pricing for modifications or accessories. Refer to Modifications section for appropriate list price addition(s).

Ⓜ For suitability of operation with rectified power supplies, see page 2.29.

④ Standard shaft for frames CDL182AT-CD5010AY, CD6000, and CD6100 is suitable for belt drive or direct coupling (within limits given in Application Section). Frames CD6200, CD6700, CD6800, and CD6900 are suitable for direct drive only.

Ⓣ Refer to Wolong for frame.

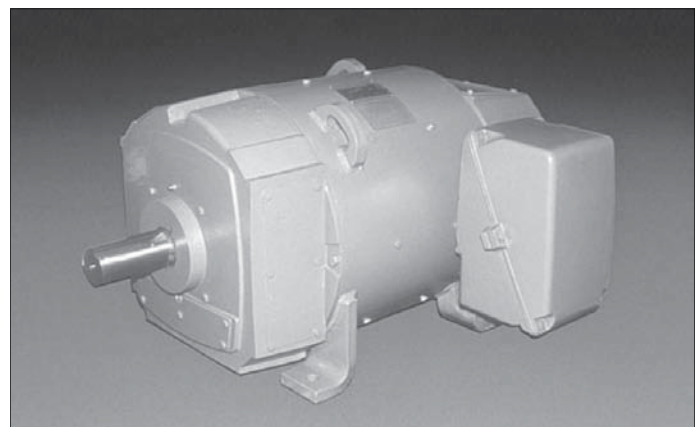

Dripproof Fully Guarded Motors

Class F Insulation

For Continuous Operation in 40°C Ambient

Separately Ventilated

Type CD
Shunt Wound

PRICES - 600V (Type C Power Supply)^②

HP	Base Speed RPM	Rated Top Speed RPM	Separately Ventilated [DPFG-SV] Suitable for constant torque to 5% of base speed		
			Basic List Price* GO-2A	Frame ^④	Dim. Pg.
				600V	
400	1750	1750	\$98010	508AT	4.15
	1150	1150	\$107730	5010AY	4.15
	850	850	\$117450	6062	4.29
	650	650	\$126090	6160	4.30
	500	500	\$141840	6164	4.30
500	400	400	\$166372	6169	4.30
	1750	1750	\$131130	6055	4.29
	1150	1150	\$138040	6058	4.29
	850	850	\$146814	6160	4.30
	650	650	\$153288	6164	4.30
600	500	500	\$166686	6262	4.31
	400	400	\$200544	6266	4.31
	1750	1750	\$181576	6058	4.29
	1150	1150	\$201664	6062	4.29
	850	850	\$203616	6164	4.30
700	650	650	\$222928	6169	4.30
	500	500	\$248968	6266	4.31
	400	400	\$266634	6271	4.31
	1150	1150	\$224164	6173	4.30
	850	850	\$226248	6268	4.31
800	650	650	\$251260	6270	4.31
	500	500	\$273780	6275	4.31
	400	400	\$291438	6280	4.31
	1150	1150	\$247248	6268	4.31
	850	850	\$249630	6270	4.31
900	650	650	\$275346	6275	4.31
	500	500	\$296988	6280	4.31
	400	400	\$317656	6881	4.33
	1150	1150	\$276126	6268	4.31
	850	850	\$278298	6270	4.31
1000	650	650	\$298690	6275	4.31
	500	500	\$318642	6881	4.33
	400	400	\$339120	6887	4.33
	1150	1150	\$299808	6268	4.31
	850	850	\$301686	6270	4.31
1250	650	650	\$320878	6275	4.31
	500	500	\$342954	6881	4.33
	400	400	\$363186	6887	4.33
	850	850	\$360222	6774	4.32
	650	650	\$379944	6779	4.32
1500	500	500	\$399922	6887	4.33
	400	400	\$423514	6985	4.34
	1150	1150	\$413182	6876	4.33
	850	850	\$413182	6881	4.33
	650	650	\$436060	6887	4.33

PRICES - 600V (Type C Power Supply)^②

HP	Base Speed RPM	Rated Top Speed RPM	Separately Ventilated [DPFG-SV] Suitable for constant torque to 5% of base speed		
			Basic List Price* GO-2A	Frame ^④	Dim. Pg.
				600V	
1750	850	850	\$465400	6890	4.33
	650	650	\$490894	6996	4.34
	500	500	\$516912	6999	4.34
2000	850	850	\$582880	6896	4.33
	650	650	\$620200	6996	4.34
	500	500	\$670020	6999	4.34
2250	850	850	\$634466	6896	4.33
	650	650	\$675090	6999	4.34
2500	850	850	\$684470	6990	4.34
	850	850	\$780486	6996	4.34

PRICES - 700V (3 Phase, 6 Controlled Pulse Power Supply)^②

HP	Base Speed RPM	Rated Top Speed RPM	Separately Ventilated [DPFG-SV] Suitable for constant torque to 5% of base speed		
			Basic List Price* GO-2A	Frame ^④	Dim. Pg.
				700V	
1500	1150	1150	\$413182	6873	4.33
	850	1000	\$413182	6876	4.33
	650	900	\$436060	6881	4.33
	500	850	\$459172	6981	4.34
	450	810	\$472718	6985	4.34
	400	770	\$486262	6985	4.34
1750	350	720	\$527278	6991	4.34
	850	960	\$465400	6881	4.33
	650	900	\$490894	6990	4.34
	500	800	\$516912	6996	4.34
	450	760	\$641588	6999	4.34
	400	720	\$675292	6999	4.34
2000	850	900	\$582880	6896	4.33
	650	840	\$620200	6996	4.34
	500	750	\$670020	6999	4.34
2250	850	850	\$634466	6896	4.33
	650	795	\$675090	6996	4.34
2500	500	710	\$729320	6999	4.34
	850	850	\$684470	6996	4.34
3000	650	750	\$728294	6999	4.34
	850	850	\$780486	6996	4.34

* Basic list price applies to frames listed. It does not include pricing for modifications or accessories. Refer to Modifications section for appropriate list price addition(s).

② For suitability of operation with rectified power supplies, see page 2.29.

④ Standard shaft for frames CDL182AT-CD5010AY, CD6000, and CD6100 is suitable for belt drive or direct coupling (within limits given in Application Section). Frames CD6200, CD6700, CD6800, and CD6900 are suitable for direct drive only.

Motor Pricing

Totally Enclosed Motors

Nonventilated

Class F Insulation

Type C Power Supply[Ⓜ]

For Continuous Operation in 40°C Ambient

Type CD
Shunt Wound

PRICES - 240 and 500 Volts

Motor Pricing

			TENV Suitable for constant torque to 5% of base speed			
HP	Base Speed RPM	Rated Top Speed RPM	Basic List Price* GO-2A	Frame [Ⓞ]		Dim. Pg.
				240V	500V	
1	1750	2300	\$3836	L182AT •	186AT	4.2
	1150	2000	\$4132	L182AT •	Ⓣ	4.2
	850	1750	\$3958	186AT	Ⓣ	4.2
	650	1600	\$6822	218AT	Ⓣ	4.10
	500	1500	\$7930	219AT	Ⓣ	4.10
	400	1200	\$9096	219AT	Ⓣ	4.10
	300	900	\$9978	219AT	Ⓣ	4.10
1.5	3500	3500	\$3006	L182AT	Ⓣ	4.2
	2500	3000	\$3088	L182AT	Ⓣ	4.2
	1750	2300	\$3394	186AT	186AT	4.2
	1150	2000	\$4472	L186AT	Ⓣ	4.2
	850	1700	\$6360	189AT	Ⓣ	4.2
	650	1600	\$7732	219AT	Ⓣ	4.10
	500	1500	\$8928	258AT	Ⓣ	4.10
	400	1200	\$10458	258AT	Ⓣ	4.10

			TENV Suitable for constant torque to 5% of base speed			
HP	Base Speed RPM	Rated Top Speed RPM	Basic List Price* GO-2A	Frame [Ⓞ]		Dim. Pg.
				240V	500V	
2	3500	3500	\$3358	186AT	186AT	4.2
	2500	3000	\$3710	186AT	186AT	4.2
	1750	2300	\$4076	L186AT	L186AT	4.2
	1150	2000	\$5446	189AT	189AT •	4.2
	850	1700	\$7008	219AT	219AT	4.10
	650	1600	\$8334	2110AT	2110AT	4.10
	500	1500	\$9978	258AT	258AT	4.10
	400	1200	\$11670	259AT	259AT	4.10
	300	900	\$14478	327AT	327AT	4.10
3	3500	3850	\$4074	L186AT	L186AT	4.2
	2500	3000	\$4520	L186AT	L186AT	4.2
	1750	2300	\$5308	L186AT	L186AT	4.2
	1150	2000	\$7360	219AT	219AT	4.10
	850	1700	\$8350	2110AT	2110AT	4.10
	650	1600	\$9856	259AT	259AT	4.10
	500	1500	\$11890	288AT	Ⓣ	4.10
	400	1200	\$14982	288AT	Ⓣ	4.10
	300	900	\$17718	328AT	Ⓣ	4.10

* Basic list price applies to frames listed. It does not include pricing for modifications or accessories. Refer to Modifications section for appropriate list price addition(s).

• Standard rating

Ⓜ For suitability of operation with rectified power supplies, see page 2.29.

Ⓞ Standard shaft for frames CDL182AT-CD5010AY, CD6000, and CD6100 is suitable for belt drive or direct coupling (within limits given in Application Section). Frames CD6200, CD6700, CD6800, and CD6900 are suitable for direct drive only.

Ⓣ Refer to Wolong for frame.

Totally Enclosed Motors

Class F Insulation

Type C Power Supply^②

For Continuous Operation in 40°C Ambient

Nonventilated, Fan Cooled,
Air-Over-Frame

Type CD
Shunt Wound

PRICES - 240 and 500 Volts

			TENV Suitable for constant torque to 5% of base speed				TEFC Suitable for constant torque to 60% of base speed				TEAO Suitable for constant torque to 40% of base speed			
HP	Base Speed RPM	Rated Top Speed RPM	Basic List Price* GO-2A	Frame ④		Dim. Pg.	Basic List Price* GO-2A	Frame ④		Dim. Pg.	Basic List Price* GO-2A	Frame ④		Dim. Pg.
				240V	500V			240V	500V			240V	500V	
5	3500	3500	\$6110	219AT	⑩	4.10	\$6341	186AT	⑩	4.6				
	2500	3000	\$7108	219AT	219AT	4.10	\$7027	L186AT	L186AT	4.6				
	1750	2300	\$8664	2110AT	2110AT •	4.10	\$8174	189AT •	189AT •	4.6				
	1500	2100					\$9175	⑩	218AT	4.13				
	1150	2000	\$10504	258AT	258AT	4.10	\$10079	⑩						
	850	1700	\$13552	287AT	287AT	4.10	\$12080	259AT	259AT	4.14	\$13858	259AT	259AT	4.10
	650	1600	\$16120	288AT	⑩	4.10	\$15585	288AT	⑩	4.14	\$17270	288AT	⑩	4.10
	500	1500	\$19104	327AT	⑩	4.10	\$18538		⑩		\$19838	327AT	⑩	4.23
	400	1200					\$21970	365AT	⑩	4.18	\$22822	365AT	366AT	4.23
300	900					\$26165		⑩		\$26470	368AT	409AT	4.23	
7.5	3500	3500	\$8452	2110AT	⑩	4.10	\$8298	L186AT	⑩	4.6				
	2500	3000	\$8664	2110AT	2110AT	4.10	\$9720	189AT	189AT	4.6				
	1750	2300	\$10582	259AT	259AT •	4.10	\$9964	2110AT •	2110AT •	4.13				
	1500	2100					\$11056	⑩	258AT	4.14				
	1150	2000	\$13452	288AT	288AT	4.10	\$12169	259AT	259AT	4.14	\$13936	259AT	259AT	4.10
	850	1700	\$16270	327AT	⑩	4.10	\$15470	288AT	288AT	4.14	\$17170	288AT	288AT	4.10
	650	1600	\$19456	365AT	⑩	4.15	\$18711	328AT	328AT	4.14	\$19988	328AT	328AT	4.23
	500	1500					\$22374	365AT	366AT	4.18	\$23174	365AT	365AT	4.23
	400	1200					\$27418	368AT	⑩	4.18	\$27560	368AT	368AT	4.23
300	900					\$32745	407AT	⑩	4.18	\$32594	407AT	409AT	4.23	
10	3500	3500					\$10854	219AT	⑩	4.13				
	2500	3000					\$11144	2110AT	2110AT	4.13				
	1750	2300	\$12958	327AT	327AT	4.10	\$11403	259AT •	259AT •	4.14	\$13290	259AT	259AT	4.10
	1500	2100					\$13119	⑩	287AT	4.14				
	1150	2000	\$15480	328AT	⑩	4.10	\$14902	288AT	288AT	4.14	\$16312	288AT	288AT	4.10
	850	1700	\$19042	366AT	366AT	4.15	\$17802	327AT	327AT	4.14	\$19198	327AT	327AT	4.23
	650	1600	\$22546	⑩	368AT	4.15	\$21898	365AT	365AT	4.18	\$22760	365AT	365AT	4.23
	500	1500					\$25928	368AT		4.18	\$26264	368AT	368AT	4.23
	400	1200					\$31761	407AT		4.18	\$31738	407AT	407AT	4.23
15	3500	3500					\$13156	258AT	⑩	4.14	\$14794	⑩	⑩	
	2500	3000					\$13496	259AT	259AT	4.14	\$15090	⑩	⑩	
	1750	2300	\$14982	328AT	328AT	4.10	\$14849	288AT •	288AT •	4.14	\$16266	288AT	288AT	4.10
	1500	2100					\$16733		288AT	4.14				
	1150	2000	\$18936	368AT	366AT	4.15	\$18264	328AT	328AT	4.14	\$19600	328AT	328AT	4.23
	850	1700	\$24496	407AT	368AT	4.15	\$21776	365AT	365AT	4.18	\$22654	365AT	365AT	4.23
	650	1600	\$29340	407AT	407AT	4.15	\$28170	368AT	368AT	4.18	\$28616	368AT	358AT	4.23
	500	1500					\$33741	407AT	407AT	4.18	\$33406	407AT	407AT	4.23
	400	1200					\$40696	409AT	409AT	4.18	\$39508	409AT	409AT	4.23
20	3500	3500					\$16256	287AT	⑩	4.14	\$17854	⑩	⑩	
	2500	3000					\$16675	288AT	288AT	4.14	\$18218	⑩	⑩	
	1750	2300	\$18450	366AT	366AT	4.15	\$17110	327AT •	327AT	4.14	\$18596	327AT	327AT	4.23
	1500	2100					\$19884	⑩	327AT	4.14				
	1150	2000	\$23544	⑩	368AT	4.15	\$21218	366AT	366AT	4.18	\$22168	366AT	366AT	4.23
	850	1700					\$27076	368AT	368AT	4.18	\$27262	358AT	368AT	4.23
	650	1600					\$33534	407AT	407AT	4.18	\$33280	407AT	407AT	4.23
	500	1500					\$39868	409AT	409AT	4.18	\$38788	409AT	409AT	4.23

Motor Pricing

* Basic list price applies to frames listed. It does not include pricing for modifications or accessories. Refer to Modifications section for appropriate list price addition(s).

• Standard rating

② For suitability of operation with rectified power supplies, see page 2.29.

④ Standard shaft for frames CDL182AT-CD5010AY, CD6000, and CD6100 is suitable for belt drive or direct coupling (within limits given in Application Section). Frames CD6200, CD6700, CD6800, and CD6900 are suitable for direct drive only.

⑩ Refer to Wolog for frame.

Totally Enclosed Motors

Class F Insulation

Type C Power Supply[®]

For Continuous Operation in 40°C Ambient

Nonventilated, Fan Cooled,
Air-Over-Frame, Unit Cooled

Type CD
Shunt Wound

PRICES - 240 and 500 Volts

			TENV Suitable for constant torque to 5% of base speed				TEFC Suitable for constant torque to 60% of base speed				TEAO Suitable for constant torque to 40% of base speed				TEAAC Suitable for constant torque to 5% of base speed			
HP	Base Speed RPM	Rated Top Speed RPM	Frame ④		Dim. Pg.	Basic List Price* GO-2A	Frame ④		Dim. Pg.	Basic List Price* GO-2A	Frame ④		Dim. Pg.	Basic List Price* GO-2A	Frame ④		Dim. Pg.	
			240V	500V			240V	500V			240V	500V			240V	500V		
25	2500	3000				\$18837	327AT	327AT	4.14	\$20098	327AT	327AT	4.23					
	1750	2300	\$22150	368AT	368AT	4.15	\$20097	328AT •	328AT	4.14	\$21194	328AT	328AT	4.23				
	1500	2100				\$21813	⑩	328AT	4.14									
	1150	2000	\$26880	409AT	407AT	4.15	\$25473	368AT	368AT	4.18	\$25868	368AT	368AT	4.23				
	850	1700				\$30912	407AT	407AT	4.18	\$31000	407AT	407AT	4.23					
	650	1600				\$38426	409AT	409AT	4.18	\$37534	409AT	409AT	4.23					
	500	1500												\$50438	368AT	368AT	4.21	
	400	1200												\$57560	407AT	407AT	4.21	
300	900												\$68454	409AT	409AT	4.21		
30	2500	3000				\$18082	365AT	365AT	4.18	\$21800	365AT	365AT	4.23					
	1750	2300	\$29066	⑩	409AT	4.15	\$19378	366AT •	366AT •	4.18	\$23096	366AT	366AT	4.23				
	1500	2100				\$22054	⑩	365AT	4.18									
	1150	2000				\$24442	407AT	368AT	4.18	\$28562	407AT	368AT	4.23					
	850	1700				\$29878	409AT	409AT	4.18	\$33998	409AT	409AT	4.23					
	650	1600								\$40900	⑩	409AT	4.23	\$41346	368AT	368AT	4.21	
	500	1500												\$55858	368AT	407AT	4.21	
	400	1200												\$63746	409AT	409AT	4.21	
300	900												\$75674	409AT	508AT	4.21		
40	2500	3000				\$25530	366AT	366AT	4.18	\$25918	366AT	366AT	4.23					
	1750	2300				\$28212	368AT •	368AT •	4.18	\$28652	368AT	368AT	4.23					
	1500	2100				\$30139	⑩	366AT	4.18									
	1150	2000				\$33490	407AT	407AT	4.18	\$33242	407AT	407AT	4.23					
	850	1700				\$40924	409AT	409AT	4.18	\$39706	409AT	409AT	4.23					
	650	1600								\$45700	504AT	504AT	4.23	\$49848	368AT	368AT	4.21	
	500	1500												\$65624	409AT	409AT	4.21	
	400	1200												\$74890	409AT	506AT	4.21	
300	900												\$88646	506AT	508AT	4.21		

Motor Pricing

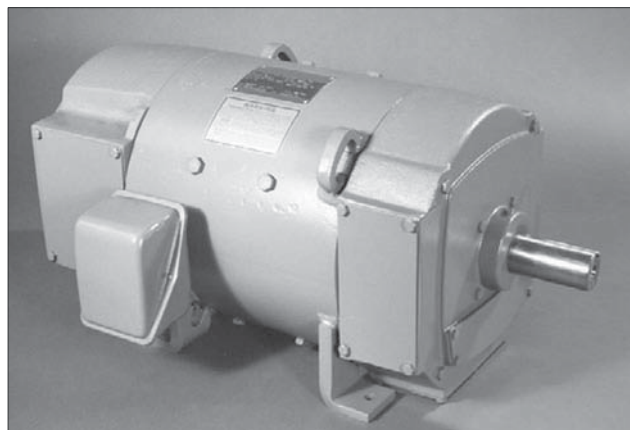

Totally Enclosed Nonventilated (TENV)
(Frame CD328AT shown above.)

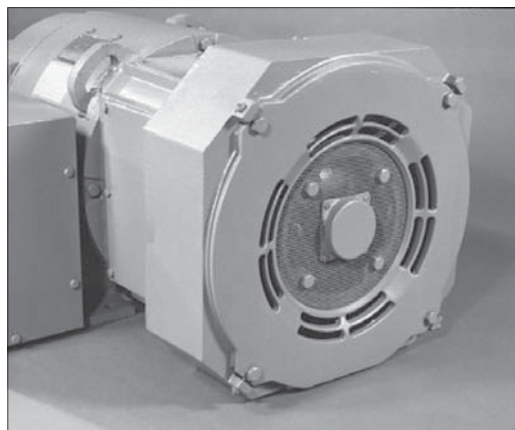

Totally Enclosed Fan Cooled (TEFC)
(Frame CD366AT shown above.)

* Basic list price applies to frames listed. It does not include pricing for modifications or accessories. Refer to Modifications section for appropriate list price addition(s).

• Standard rating

② For suitability of operation with rectified power supplies, see page 2.29.

④ Standard shaft for frames CDL182AT-CD5010AY, CD6000, and CD6100 is suitable for belt drive or direct coupling (within limits given in Application Section). Frames CD6200, CD6700, CD6800, and CD6900 are suitable for direct drive only.

⑩ Refer to Wolong for frame.

Totally Enclosed Motors

Class F Insulation

Type C Power Supply[Ⓜ]

For Continuous Operation in 40°C Ambient

Fan Cooled, Air-Over-Frame,
Unit Cooled

Type CD
Shunt Wound

PRICES - 240 and 500 Volts

			TEFC Suitable for constant torque to 60% of base speed				TEAO Suitable for constant torque to 40% of base speed				TEAAC Suitable for constant torque to 5% of base speed			
HP	Base Speed RPM	Rated Top Speed RPM	Basic List Price* GO-2A	Frame ④		Dim. Pg.	Basic List Price* GO-2A	Frame ④		Dim. Pg.	Basic List Price* GO-2A	Frame ④		Dim. Pg.
				240V	500V			240V	500V			240V	500V	
50	1750	2100	\$34031	409AT	409AT •	4.18	\$33712	409AT	409AT	4.23	\$34210		366AT	4.21
	1500	2000	\$34456	⑩	⑩									
	1150	2000	\$38638	L409AT	409AT	4.18	\$37718	L409AT	409AT	4.23				
	850	1700					\$43070	504AT	405AT	4.23	\$44336	368AT	368AT	4.21
	650	1600					\$51150	506AT	506AT	4.23	\$57630	409AT	4007AT	4.21
	500	1500									\$74358	409AT	504AT	4.21
	400	1200									\$84858	506AT	506AT	4.21
60	1750	2100	\$37051	409AT	409AT •	4.18	\$36338	L409AT	409AT	4.23	\$37680		366AT	4.21
	1500	2000	\$38440	⑩	409AT	4.18								
	1150	2000					\$41336	504AT	504AT	4.23	\$40936	368AT	368AT	4.21
	850	1700					\$47964	506AT	506AT	4.23	\$50740	407AT	407AT	4.21
	650	1600					\$56736	508AT	508AT	4.23	\$64880	504AT	409AT	4.21
	500	1500									\$82352	504AT	504AT	4.21
	400	1200									\$93980	506AT	506AT	4.21
75	1750	2100	\$41283	409AT	409AT	4.18	\$40018	L409AT	409AT	4.23	\$42412		366AT	4.21
	1500	2000	\$43948	⑩	409AT	4.18								
	1150	2000					\$45700	504AT	504AT	4.23	\$49046	L407AT	407AT	4.21
	850	1700					\$54432	⑩	506AT	4.23	\$59850	L409AT	409AT	4.21
	650	1600									\$75008	504AT	504AT	4.21
	500	1500									\$93312	506AT	506AT	4.21
	400	1200									\$106448	508AT	508AT	4.21
100	1750	2100					\$45880	506AT	506AT	4.23	\$49454	L407AT	407AT	4.21
	1500	2000									\$55728		407AT	4.21
	1150	2000					\$55830	⑩	508AT	4.23	\$61916	L407AT	407AT	4.21
	850	1700					\$62810	⑩	⑩		\$74050	504AT	409AT	4.21
	650	1600									\$90424	506AT	506AT	4.21
	500	1500									\$109624	508AT	508AT	4.21
	400	1200									\$125104	6055	5010AY	4.38, 4.21
300	900									\$146734	6058	6058	4.38	

Motor Pricing

* Basic list price applies to frames listed. It does not include pricing for modifications or accessories. Refer to Modifications section for appropriate list price addition(s).

• Standard rating

Ⓜ For suitability of operation with rectified power supplies, see page 2.29.

④ Standard shaft for frames CDL182AT-CD5010AY, CD6000, and CD6100 is suitable for belt drive or direct coupling (within limits given in Application Section). Frames CD6200, CD6700, CD6800, and CD6900 are suitable for direct drive only.

⑩ Refer to Wolong for frame.

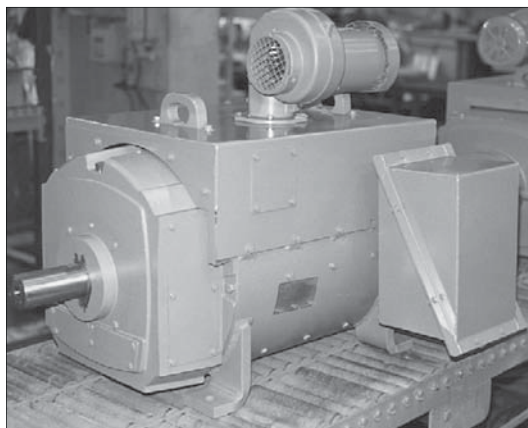

Totally Enclosed Air-Over-Frame (TEAO)
(Frame CDL506AT shown above.)

Totally Enclosed Motors

Unit Cooled

Class F Insulation

Type C Power Supply^②

For Continuous Operation in 40°C Ambient

Type CD

Shunt Wound

PRICES - 500 Volts

Motor Pricing

			TEAAC Suitable for constant torque to 5% of base speed		
HP	Base Speed RPM	Rated Top Speed RPM	Basic List Price* GO-2A	Frame ④	Dim. Pg.
				500V	
125	1750	2000	\$58594	407AT	4.21
	1500	2000	\$66322	409AT	4.21
	1150	2000	\$74182	504AT	4.21
	850	1700	\$87346	506AT ②①	4.21
	650	1600	\$104546	506AT ②①	4.21
	500	1500	\$124216	508AT ②①	4.21
	400	1200	\$141756	5010AY	4.22
	300	900	\$165894	6058	4.38
150	1750	2000	\$67302	504AT ②①	4.21
	1500	2000	\$76458	504AT ②①	4.21
	1150	2000	\$85988	504AT ②①	4.21
	850	1700	\$99962	508AT ②①	4.21
	650	1600	\$117698	508AT ②①	4.21
	500	1500	\$137568	5010AY	4.22
	400	1200	\$156994	6058	4.38
	300	900	\$183392	6062	4.38

			TEAAC Suitable for constant torque to 5% of base speed		
HP	Base Speed RPM	Rated Top Speed RPM	Basic List Price* GO-2A	Frame ④	Dim. Pg.
				500V	
200	1750	2000	\$83750	504AT ②①	4.21
	1500	2000	\$95692	506AT ②①	4.21
	1150	2000	\$108552	506AT ②①	4.21
	850	1700	\$123676	508AT	4.21
	650	1600	\$141900	5010AY	4.22
	500	1500	\$161614	6062	4.38
	400	1200	\$184436	6157	4.38
	300	900	\$214830	6164	4.38
250	1750	2000	\$106394	506AT ②①	4.21
	1500	2000	\$118590	508AT ②①	4.21
	1150	2000	\$130058	508AT ②①	4.21
	850	1700	\$145882	5010AY	4.22
	650	1600	\$164048	5010AY	4.22
	500	1500	\$183126	6062	4.38
	400	1200	\$208986	6169	4.38
	300	900	\$242882	6259	4.38

* Basic list price applies to frames listed. It does not include pricing for modifications or accessories. Refer to Modifications section for appropriate list price addition(s).

② For suitability of operation with rectified power supplies, see page 2.29 .

④ Standard shaft for frames CDL182AT-CD5010AY, CD6000, and CD6100 is suitable for belt drive or direct coupling (within limits given in Application Section). Frames CD6200, CD6700, CD6800, and CD6900 are suitable for direct drive only.

②① Totally enclosed Air-to-Air cooled machine provided in "B" size cooler.

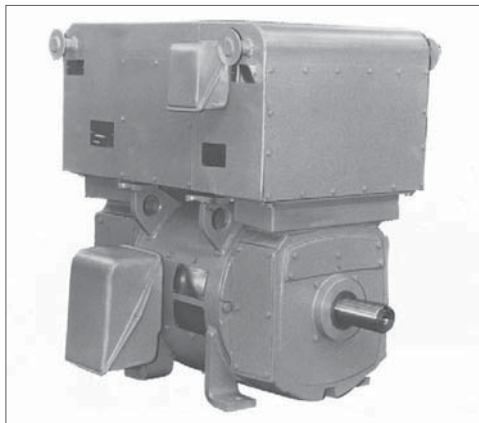

Totally Enclosed Air-To-Air Cooled (TEAAC)
(Frame CD506AT shown above.)

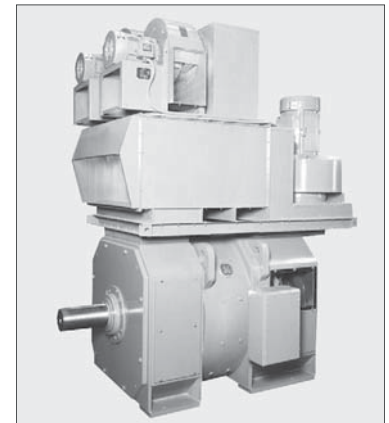

Totally Enclosed Air-To-Air Cooled
(Frame CD6774 shown above.)

Totally Enclosed Motors

Unit Cooled

Class F Insulation

Type C Power Supply^②

For Continuous Operation in 40°C Ambient

Type CD

Shunt Wound

PRICES - 500 and 700 Volts

			TEAAC Suitable for constant torque to 5% of base speed					TEWAC Suitable for constant torque to 5% of base speed				
HP	Base Speed RPM	Rated Top Speed RPM	Basic List Price* GO-2A	Frame ④	Dim. Pg.	Frame ④	Dim. Pg.	Basic List Price* GO-2A	Frame ④	Dim. Pg.	Frame ④	Dim. Pg.
				500V		700V			500V		700V	
300	1750	1900	\$129550	506AT ②①	4.21							
	1500	1800	\$140758	508AT ②①	4.21							
	1150	1600	\$150754	5010AY	4.22							
	850	1500	\$166954	5010AY	4.22			\$136864				
	650	1600	\$184690	6062	4.38			\$149210	6062	4.40		
	500	1300	\$202812	6160	4.38			\$171898	6160	4.40		
	400	1200	\$231450	6169	4.38			\$206726	6169	4.40		
300	900	\$268502	6262	4.38			\$232074	6262	4.40			
400	1750	1900	\$176754	5010AY	4.22			\$144764	⑩			
	1500	1800	\$184466	5010AY	4.22			\$150668	⑩			
	1150	1500	\$190314	5010AY	4.22			\$156216	⑩			
	850	1500	\$206562	6062	4.38			\$172282	6062	4.40		
	650	1400	\$222664	6160	4.38			\$183022	6160	4.40		
	500	1200	\$238264	6259	4.38			\$200786	6259	4.40		
	400	1000	\$271908	6262	4.38			\$240776	6262	4.40		
300	750	\$314530	6266	4.38			\$269522	6266	4.40			
500	1750	1900	\$224922	6055	4.38			\$183394	6055	4.40		
	1500	1700	\$227516	6058	4.38			\$186662	6058	4.40		
	1150	1500	\$228018	6058	4.38	6062	4.38	\$189686	6058	4.40	6062	4.40
	850	1400	\$243648	6160	4.38	6164	4.38	\$205952	6160	4.40	6164	4.40
	650	1200	\$257420	6164	4.38	6169	4.38	\$214442	6164	4.40	6169	4.40
	500	1000	\$269978	6262	4.38	6262	4.38	\$226500	6262	4.40	6262	4.40
	400	1000	\$308100	6266	4.38	6266	4.38	\$271004	6266	4.40	6266	4.40
300	750	\$355602	6271	4.38	6271	4.38	\$302682	6271	4.40	6271	4.40	
600	1750	1900	\$280788	6063	4.38			\$239134	6063	4.40		
	1500	1700	\$283900	6063	4.38			\$245142	6063	4.40		
	1150	1500	\$287014	6063	4.38	6160	4.38	\$251152	6066	4.40	6062	4.40
	850	1300	\$305424	6173	4.38	6169	4.38	\$264882	6173	4.40	6169	4.40
	650	1200	\$334392	6268	4.38	6262	4.38	\$281404	6268	4.40	6262	4.40
	500	1000	\$373452	6275	4.38	6266	4.38	\$308170	6275	4.40	6266	4.40
	400	1000	\$406224	6280	4.38	6271	4.38	\$333292	6280	4.40	6271	4.40
300	750	\$440312	6881	4.39	6887	4.39	\$363532	6881	4.41	6887	4.41	
700	1750	1800	\$313748	6165	4.38			\$269272	6165	4.40		
	1500	1600	\$316736	⑩				\$274764	6165	4.40		
	1150	1300	\$319718	6268	4.38	6160	4.38	\$280632	6168	4.40	6160	4.40
	850	1200	\$338134	6268	4.38	6259	4.38	\$295064	6173	4.40	6259	4.40
	650	1000	\$367928	6270	4.38	6262	4.38	\$313468	6270	4.40	6262	4.40
	500	1000	\$407750	6280	4.38	6266	4.38	\$342226	6275	4.40	6266	4.40
	400	1000	\$442850	6881	4.39	6779	4.39	\$368418	6881	4.41	6779	4.41
300	750	\$480010	6887	4.39	6887	4.39	\$402464	6887	4.41	6887	4.41	

Motor Pricing

* Basic list price applies to frames listed. It does not include pricing for modifications or accessories. Refer to Modifications section for appropriate list price addition(s).

② For suitability of operation with rectified power supplies, see page 2.29.

④ Standard shaft for frames CDL182AT-CD5010AY, CD6000, and CD6100 is suitable for belt drive or direct coupling (within limits given in Application Section). Frames CD6200, CD6700, CD6800, and CD6900 are suitable for direct drive only.

⑩ Refer to Wolong for frame.

②① Totally enclosed Air-to-Air cooled machine provided in "B" size cooler.

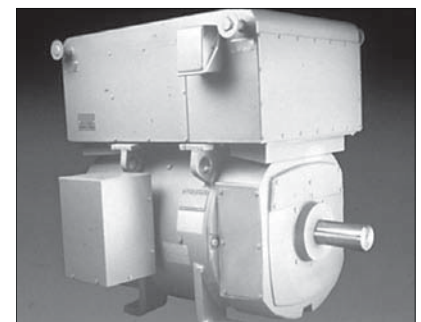

Totally Enclosed Air-To-Air Cooled
(Frame CD6160 shown above.)

Totally Enclosed Motors

Unit Cooled

Class F Insulation

Type C Power Supply[Ⓜ]

For Continuous Operation in 40°C Ambient

Type CD

Shunt Wound

PRICES - 500 and 700 Volts

Motor Pricing

			TEAAC Suitable for constant torque to 5% of base speed					TEWAC Suitable for constant torque to 5% of base speed				
HP	Base Speed RPM	Rated Top Speed RPM	Basic List Price* GO-2A	Frame ④	Dim. Pg.	Frame ④	Dim. Pg.	Basic List Price* GO-2A	Frame ④	Dim. Pg.	Frame ④	Dim. Pg.
				500V		700V			500V		700V	
800	1150	1250	\$351042	6268	4.38	6268	4.38	\$308954	6268	4.40	6268	4.40
	850	1200	\$369286	6270	4.38	6270	4.38	\$323974	6270	4.40	6270	4.40
	650	1000	\$399686	6275	4.38	6275	4.38	\$344182	6275	4.40	6275	4.40
	500	1000	\$439998	6779	4.39	6280	4.38	\$374756	6779	4.41	6280	4.40
	400	1000	\$477234	6881	4.39	6881	4.39	\$401824	6881	4.41	6881	4.41
	300	750	\$517280	6887	4.39	6887	4.39	\$439544	6887	4.41	6887	4.41
900	1150	1250	\$381212	6268	4.38	6268	4.38	\$336296	6268	4.40	6268	4.40
	850	1000	\$399138	6270	4.38	6270	4.38	\$351816	6270	4.40	6270	4.40
	650	1000	\$429964	6774	4.39	6275	4.38	\$373762	6774	4.41	6275	4.40
	500	1000	\$470552	6779	4.39	6779	4.39	\$406004	6779	4.41	6779	4.41
	400	1000	\$509772	6887	4.39	6881	4.39	\$433794	6887	4.41	6881	4.41
	300	750	\$552550	6985	4.39	6985	4.39	\$475076	6985	4.41	6985	4.41
1000	1150	1250	\$410390	6270	4.38	6268	4.38	\$362800	6270	4.40	6268	4.40
	850	1000	\$427882	6275	4.38	6275	4.38	\$378744	6275	4.40	6275	4.40
	650	1000	\$458988	6774	4.39	6779	4.39	\$402370	6774	4.41	6779	4.41
	500	1000	\$499676	6881	4.39	6881	4.39	\$436160	6881	4.41	6881	4.41
	400	1000	\$540756	6887	4.39	6887	4.39	\$464544	6887	4.41	6887	4.41
	300	750	\$586132	6985	4.39	6985	4.39	\$509288	6985	4.41	6985	4.41
1250	1150	1150	\$479772	6776	4.39			\$426032	6776	4.41		
	850	1000	\$495774	6778	4.39	6977	4.39	\$442776	6778	4.41	6977	4.41
	650	1000	\$527092	6785	4.39	6977	4.39	\$470394	6785	4.41	6977	4.41
	500	1000	\$567450	6896	4.39	6981	4.39	\$507628	6896	4.41	6981	4.41
	400	1000	\$612732	6996	4.39	6985	4.39	\$537054	6996	4.41	6985	4.41
1500	850	900	\$559170			6881	4.39	\$503050			6881	4.41
	650	900	\$590172			6887	4.39	\$534428			6887	4.41
	500	850	\$629594			⑩		\$574630			⑩	
	400	770	\$678598			⑩		\$604624			⑩	
1750	850	900	\$619054			6881	4.39	\$560368			6881	4.41
	650	900	\$649360			6990	4.39	\$595322			6990	4.41
	500	800	\$687416			6996	4.39	\$638134			6996	4.41
2000	850	900	\$757744			6896	4.39	\$699456			6896	4.41
	650	840	\$806260			6996	4.39	\$744240			6996	4.41
	500	750	\$871026			6999	4.39	\$804024			6999	4.41
2250	850	850	\$818998			6896	4.39	\$759568			6896	4.41
	650	795	\$867340			6996	4.39	\$808202			6996	4.41
	500	710	\$931512			6999	4.39	\$871070			6999	4.41
	850	850	\$877976			6996	4.39	\$817706			6996	4.41
	650	750	\$925890			6999	4.39	\$870062			6999	4.41
3000	850	850	\$990246			6999	4.39	\$929018			6999	4.41

* Basic list price applies to frames listed. It does not include pricing for modifications or accessories. Refer to Modifications section for appropriate list price addition(s).

Ⓜ For suitability of operation with rectified power supplies, see page 2.29.

④ Standard shaft for frames CDL182AT-CD5010AY, CD6000, and CD6100 is suitable for belt drive or direct coupling (within limits given in Application Section). Frames CD6200, CD6700, CD6800, and CD6900 are suitable for direct drive only.

⑩ Refer to Wolong for frame.

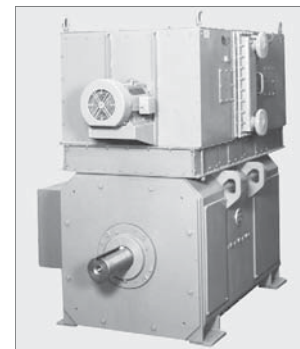

Totally Enclosed Water-To-Air Cooled
(Frame CD6160 shown above.)

Totally Enclosed 30 Minute Rating Motors¹⁴

Nonventilated

Class F Insulation

Type C Power Supply²

For Operation in 40°C Ambient

Type CD

Shunt Wound

PRICES - 240 and 500 Volts

HP	Base Speed RPM	Rated Top Speed RPM	Basic List Price* GO-2A	Frame ④		Dim. Pg.
				240V	500V	
1	1750	2300	\$2198	L182AT	⑩	4.2
	1150	2000	\$2476	L182AT	⑩	4.2
	850	1700	\$3202	186AT	⑩	4.2
1.5	1750	2300	\$2468	L182AT	⑩	4.2
	1150	2000	\$2882	L182AT	⑩	4.2
	850	1700	\$4300	186AT	⑩	4.2
2	1750	2300	\$2726	L182AT	⑩	4.2
	1150	2000	\$3346	L186AT	⑩	4.2
	850	1700	\$4848	189AT	⑩	4.2
3	1750	2300	\$3304	186AT	⑩	4.2
	1150	2000	\$4740	189AT	⑩	4.2
	850	1700	\$5778	219AT	⑩	4.10
	650	1600	\$6820	2110AT	⑩	4.10
5	1750	2300	\$4914	L186AT	⑩	4.2
	1150	2000	\$6064	219AT	⑩	4.10
	850	1700	\$7264	2110AT	⑩	4.10
	650	1600	\$8746	259AT	⑩	4.10
7.5	1750	2300	\$5994	2110AT	2110AT	4.10
	1150	2000	\$7318	258AT	258AT	4.10
	850	1700	\$8682	259AT	⑩	4.10
	650	1600	\$10500	288AT	⑩	4.10
10	1750	2300	\$6874	2110AT	2110AT	4.10
	1150	2000	\$8358	259AT	259AT	4.10
	850	1700	\$9990	288AT	288AT	4.10
	650	1600	\$12286	328AT	328AT	4.10
15	1750	2300	\$8332	259AT	259AT	4.10
	1150	2000	\$10248	288AT	288AT	4.10
	850	1700	\$12220	327AT	327AT	4.10
	650	1600	\$15190	365AT	365AT	4.15
20	1750	2300	\$9600	288AT	288AT	4.10
	1150	2000	\$11908	328AT	328AT	4.10
	850	1700	\$14608	365AT	365AT	4.15
	650	1600	\$18090	365AT	365AT	4.15
25	1750	2300	\$10842	327AT	327AT	4.10
	1150	2000	\$13704	365AT	365AT	4.15
	850	1700	\$16674	365AT	365AT	4.15
	650	1600	\$20724	366AT	366AT	4.15
30	1750	2300	\$11962	328AT	328AT	4.10
	1150	2000	\$15162	365AT	365AT	4.15
	850	1700	\$18538	366AT	366AT	4.15
	650	1600	\$22816	368AT	368AT	4.15

HP	Base Speed RPM	Rated Top Speed RPM	Basic List Price* GO-2A	Frame ④		Dim. Pg.
				240V	500V	
40	1750	2100	\$14122	365AT	365AT	4.15
	1150	2000	\$18064	366AT	365AT	4.15
	850	1700	\$22074	366AT	366AT	4.15
	650	1600	\$27000	407AT	368AT	4.15
50	1750	2100	\$16170	365AT	365AT	4.15
	1150	2000	\$20844	366AT	366AT	4.15
	850	1700	\$25624	368AT	368AT	4.15
60	1750	2100	\$31050	407AT	407AT	4.15
	1150	2000	\$18550	366AT	366AT	4.15
	850	1700	\$23856	368AT	368AT	4.15
75	1750	2100	\$29122	407AT	407AT	4.15
	1150	2000	\$34966	409AT	409AT	4.15
	850	1700	\$21844	366AT	366AT	4.15
100	1750	2100	\$28096	407AT	407AT	4.15
	1150	2000	\$33462	L409AT	409AT	4.15
	850	1700	\$40366	504AT	409AT	4.15
125	1750	2100	\$40840	504AT	409AT	4.15
	1150	2000	\$27474	368AT	368AT	4.15
	850	1700	\$34398	L407AT	407AT	4.15
	650	1600	\$40366	504AT	409AT	4.15
150	1750	2000	\$48940	506AT	506AT	4.15
	1150	2000	\$32590	L407AT	407AT	4.15
	850	1700	\$40366	L409AT	409AT	4.15
	650	1600	\$47304	506AT	506AT	4.15
200	1750	2000	\$56364	508AT	508AT	4.15
	1150	2000	\$37558	L409AT	409AT	4.15
	850	1700	\$46456	504AT	506AT	4.15
	650	1600	\$53556	506AT	508AT	4.15
250	1750	1900	\$63466	508AT	508AT	4.15
	1150	2000	\$47710	504AT	504AT	4.15
	850	1700	\$57564	506AT	506AT	4.15
300	1750	1900	\$65652	508AT	508AT	4.15
	1150	1700	\$58726	L506AT	506AT	4.15
400	1750	1900	\$69190	L508AT	508AT	4.15
	1150	1900	\$70470	L506AT	506AT	4.15
400	1750	1900	\$81204	L508AT	508AT	4.15
	1750	1900	\$98010	⑩	508AT	4.15

Motor Pricing

* Basic list price applies to frames listed. It does not include pricing for modifications or accessories. Refer to Modifications section for appropriate list price additions).

② For suitability of operation with rectified power supplies, see page 2.29.

④ Standard shaft for frames CDL182AT-CD5010AY, CD6000, and CD6100 is suitable for belt drive or direct coupling (within limits given in Application Section). Frames CD6200, CD6700, CD6800, and CD6900 are suitable for direct drive only.

⑩ Refer to Wolong for frame.

⑭ The NEMA definition for short time rated motors is as follows "All short time ratings are based upon a corresponding short time load test, which shall commence only when the windings and other parts of the machine are within 5°C of the ambient temperature at the time of starting the test." This means that field voltage should be removed when the motor is not operating.

These short time rated motors have 150% occasionally repeated overload capability at all speeds within the standard speed range. To add for wider than standard speed range, use rated HP and the tables on page 3.22 item 28 (frame size may be different from standard).

Totally Enclosed 60 Minute Rating Motors¹⁴

Nonventilated

Class F Insulation

Type C Power Supply²

For Operation in 40°C Ambient

Type CD

Shunt Wound

PRICES - 240 and 500 Volts

Motor Pricing

HP	Base Speed RPM	Rated Top Speed RPM	Basic List Price* GO-2A	Frame ④		Dim. Pg.
				240V	500V	
1	1750	2300	\$2268	L182AT	⑩	4.2
	1150	2000	\$2686	L182AT	⑩	4.2
	850	1700	\$3166	186AT	⑩	4.2
	650	1600	\$5456	L186	⑩	4.2
1.5	1750	2300	\$2714	L182AT	⑩	4.2
	1150	2000	\$3576	L182AT	⑩	4.2
	850	1700	\$5088	186AT	⑩	4.2
	650	1600	\$6186	218AT	⑩	4.10
2	1750	2300	\$3260	L182AT	⑩	4.2
	1150	2000	\$4356	L186AT	⑩	4.2
	850	1700	\$5606	189AT	⑩	4.2
	650	1600	\$6650	219AT	⑩	4.10
3	1750	2300	\$4246	186AT	⑩	4.2
	1150	2000	\$5888	189AT	⑩	4.2
	850	1700	\$6680	219AT	⑩	4.10
	650	1600	\$7884	2110AT	⑩	4.10
5	1750	2300	\$5686	189AT	⑩	4.2
	1150	2000	\$7010	258AT	⑩	4.10
	850	1700	\$8402	259AT	259AT	4.10
	650	1600	\$10840	259AT	259AT	4.10
7.5	1750	2300	\$6930	2110AT	2110AT	4.10
	1150	2000	\$8464	258AT	259AT	4.10
	850	1700	\$10760	288AT	288AT	4.10
	650	1600	\$13016	328AT	328AT	4.10
10	1750	2300	\$7948	258AT	2110AT	4.10
	1150	2000	\$10364	259AT	259AT	4.10
	850	1700	\$12384	288AT	327AT	4.10
	650	1600	\$15232	328AT	328AT	4.10
15	1750	2300	\$10328	288AT	288AT	4.10
	1150	2000	\$12704	328AT	328AT	4.10
	850	1700	\$15148	365AT	366AT	4.15
	650	1600	\$19596	365AT	365AT	4.15
20	1750	2300	\$11902	327AT	327AT	4.10
	1150	2000	\$14760	365AT	365AT	4.15
	850	1700	\$18834	365AT	366AT	4.15
	650	1600	\$23328	366AT	366AT	4.15
25	1750	2300	\$13980	328AT	328AT	4.10
	1150	2000	\$17720	365AT	365AT	4.15
	850	1700	\$21504	366AT	366AT	4.15
	650	1600	\$26730	368AT	368AT	4.15

HP	Base Speed RPM	Rated Top Speed RPM	Basic List Price* GO-2A	Frame ④		Dim. Pg.
				240V	500V	
30	1750	2300	\$15502	365AT	328AT	4.15, 4.10
	1150	2000	\$19552	366AT	365AT	4.15
	850	1700	\$23902	366AT	366AT	4.15
	650	1600	\$29424	407AT	368AT	4.15
40	1750	2100	\$19624	366AT	365AT	4.15
	1150	2000	\$23296	366AT	366AT	4.15
	850	1700	\$28468	368AT	368AT	4.15
	650	1600	\$33264	407AT	407AT	4.15
50	1750	2100	\$23672	366AT	366AT	4.15
	1150	2000	\$26878	368AT	368AT	4.15
	850	1700	\$31160	407AT	407AT	4.15
	650	1600	\$37256	409AT	409AT	4.15
60	1750	2100	\$25774	368AT	366AT	4.15
	1150	2000	\$29772	407AT	407AT	4.15
	850	1700	\$34712	504AT	409AT	4.15
	650	1600	\$41728	504AT	409AT	4.15
75	1750	2100	\$28718	368AT	368AT	4.15
	1150	2000	\$33264	L407AT	407AT	4.15
	850	1700	\$39886	504AT	504AT	4.15
	650	1600	\$47728	506AT	506AT	4.15
100	1750	2000	\$33408	L407AT	407AT	4.15
	1150	2000	\$41004	409AT	409AT	4.15
	850	1700	\$46588	506AT	506AT	4.15
	650	1600	\$56376	508AT	508AT	4.15
125	1750	2000	\$37544	L409AT	409AT	4.15
	1150	2000	\$46588	504AT	506AT	4.15
	850	1700	\$54388	506AT	508AT	4.15
	650	1600	\$64928	508AT	508AT	4.15
150	1750	2000	\$43270	L506AT	504AT	4.15
	1150	2000	\$53392	506AT	506AT	4.15
	850	1700	\$61736	508AT	508AT	4.15
200	1750	2000	\$54856	L508AT	508AT	4.15
	1150	1800	\$66448	L508AT	508AT	4.15

* Basic list price applies to frames listed. It does not include pricing for modifications or accessories. Refer to Modifications section for appropriate list price addition(s).

② For suitability of operation with rectified power supplies, see page 2.29.

④ Standard shaft for frames CDL182AT-CD5010AY, CD6000, and CD6100 is suitable for belt drive or direct coupling (within limits given in Application Section). Frames CD6200, CD6700, CD6800, and CD6900 are suitable for direct drive only.

⑩ Refer to Wolong for frame.

⑭ The NEMA definition for short time rated motors is as follows "All short time ratings are based upon a corresponding short time load test, which shall commence only when the windings and other parts of the machine are within 5°C of the ambient temperature at the time of starting the test." This means that field voltage should be removed when the motor is not operating.

These short time rated motors have 150% occasionally repeated overload capability at all speeds within the standard speed range. To add for wider than standard speed range, use rated HP and the tables on page 3.22 item 28 (frame size may be different from standard).

③ 365AT page 4.15; 328AT page 4.10.

Explosionproof and Dust-Ignitionproof Motors

Class F Insulation
For Continuous Operation in 40°C Ambient

Nonventilated and Fan Cooled

Type CD
Shunt Wound

UL File #29056

CSA File #056228

Class I Group D

Class II Group E, F, G - See Page 2.25

PRICES - 180 Volts (Type K Power Supply^②)

HP	Base Speed RPM	Rated Top Speed RPM	Basic List Price* GO-2X	Enclosure ⑥	Frame ④†	Dim. Pg.
1	1750	2050	\$8082	TENV	188AT	4.19
	1150	1380	\$8457	TENV	188AT	4.19
1.5	2500	2750	\$8568	TENV	188AT	4.19
	1750	2050	\$8790	TENV	189AT	4.19
	1150	1380	\$9609	TENV	189AT	4.19
2	2500	2750	\$9162	TENV	189AT	4.19
	1750	2050	\$9927	TENV	189AT	4.19
	1150	1380	\$11085	TEFC	189AT	4.19
3	2500	2750	\$10674	TEFC	189AT	4.19
	1750	2050	\$11916	TEFC	189AT	4.19
5	1150	1380	\$16776	TENV	2110AT	4.19
	2500	2750	\$14061	TENV	2110AT	4.19
	1750	2050	\$17058	TENV	2110AT	4.19
5	1150	1380	\$19719	TEFC	2110AT	4.19

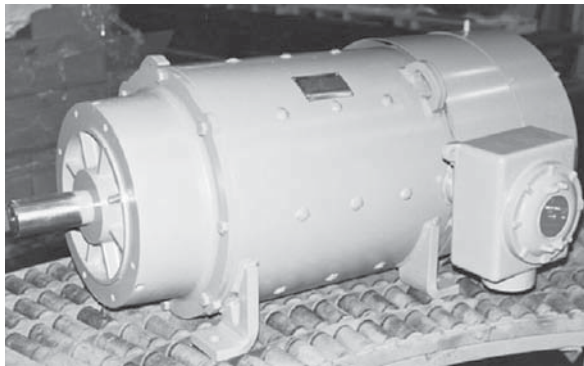

Totally Enclosed Fan Cooled Explosionproof (TEFC-XP)
(Frame CD409AT shown above.)

* Basic List price applies to frames listed. It does not include pricing for modifications or accessories. Refer to Modification section for appropriate list price addition(s).

② For Suitability of operation with rectified power supplies, see page 2.29.

④† Standard shaft for frames CDL188AT-CD409AT is suitable for belt drive or direct coupling (within limits given in Application Section.)

⑥ TENV-Totally Enclosed Nonventilated

TEFC- Totally Enclosed Fan Cooled

⑩ Refer to Wolong for frame.

⑮ UL Operating Temperature Code T4-135°C.

PRICES - 240 and 500 Volts (Type C Power Supply^②)

HP	Base Speed RPM	Rated Top Speed RPM	Basic List Price* GO-2X	Enclosure ⑥	Frame ④†		Dim. Pg.
					240V	500V	
1	1750	2300	\$8082	TENV	188AT	188AT	4.19
	1150	2000	\$8457	TENV	188AT	⑩	4.19
	850	1700	\$10635	TENV	188AT	⑩	4.19
1.5	2500	3000	\$8568	TENV	188AT	⑩	4.19
	1750	2300	\$8790	TENV	189AT	189AT	4.19
	1150	2000	\$9609	TENV	189AT	⑩	4.19
	850	1700	\$14310	TENV	2110AT	⑩	4.19
2	3500	3850	\$8316	TENV	188AT	⑩	4.19
	2500	3000	\$9162	TENV	189AT	189AT	4.19
	1750	2300	\$9927	TENV	189AT	189AT	4.19
	1150	2000	\$11085	TEFC	189AT	189AT	4.19
	850	1700	\$15768	TENV	2110AT	2110AT	4.19
3	3500	3850	\$9393	TENV	189AT	⑩	4.19
	2500	3000	\$10674	TEFC	189AT	189AT	4.19
	1750	2300	\$11916	TEFC	189AT	189AT	4.19
	1150	2000	\$16776	TENV	2110AT	2110AT	4.19
	850	1700	\$18789	TENV	2110AT	2110AT	4.19
5	3500	3850	\$12057	TENV	2110AT	⑩	4.19
	2500	3000	\$14061	TENV	2110AT	2110AT	4.19
	1750	2300	\$17058	TENV	2110AT	2110AT	4.19
	1150	2000	\$19719	TEFC	2110AT	2110AT	4.19
	850	1700	\$23634	TEFC	288AT	288AT	4.19
7.5	3500	3500	\$16452	TEFC	2110AT	⑩	4.19
	2500	3000	\$18732	TEFC	2110AT	2110AT	4.19
	1750	2300	\$19491	TEFC	2110AT	2110AT	4.19
	1150	2000	\$23811	TEFC	288AT	288AT	4.19
	850	1700	\$30267	TEFC	288AT	288AT	4.19
10	3500	3500	\$19821	TEFC	2110AT	⑩	4.19
	2500	3000	\$20868	TEFC	2110AT	2110AT	4.19
	1750	2300	\$21399	TEFC	288AT	288AT	4.19
	1150	2000	\$27684	TEFC	288AT	288AT	4.19
	850	1700	\$31158	TEFC	328AT	328AT	4.19
15	3500	3500	\$25740	TEFC	288AT	⑩	4.19
	2500	3000	\$25173	TEFC	288AT	288AT	4.19
	1750	2300	\$27618	TEFC	288AT	288AT	4.19
	1150	2000	\$33300	TEFC	328AT	328AT	4.19
	850	1700	\$39765	TEFC	407AT	⑩	4.19
20	2500	3000	\$31101	TEFC	288AT	288AT	4.19
	1750	2300	\$31794	TEFC	328AT	328AT	4.19
	1150	2000	\$38745	TEFC	407AT	⑩	4.19
	850	1700	\$49443	TEFC	407AT	⑩	4.19
25	2500	3000	\$35133	TEFC	288AT	288AT	4.19
	1750	2300	\$35691	TEFC	328AT	328AT	4.19
	1150	2000	\$46512	TEFC	407AT	⑩	4.19
	850	1700	\$56448	TEFC	407AT	⑩	4.19
30	1750	2300	\$40695	TEFC	407AT	⑩	4.19
	1150	2000	\$51327	TEFC	407AT	⑩	4.19
	850	1700	\$62745	TEFC	409AT	⑩	4.19
40	1750	2100	\$51516	TEFC	407AT	⑩	4.19
	1150	2000	\$61155	TEFC	407AT	⑩	4.19
	850	1700	\$74730	TEFC	409AT	⑩	4.19
50	1750	2100	\$62145	TEFC	409AT	⑩	4.19
	1150	2000	\$70557	TEFC	409AT	⑩	4.19
60	1750	2100	\$67659	TEFC	409AT	⑩	4.19
75	1750	2100	\$75387	TEFC	409AT ⑮	⑩	4.19

Motor Pricing

Explosionproof and Dust-Ignitionproof Motors

Class F Insulation
For Continuous Operation in -25°C to 40°C Ambient

Nonventilated and Fan Cooled

Type CD
Shunt Wound

All listed explosionproof motors meet UL operating temperature code T4A-120°C, except 75 HP, 1750 TEFC, CD409AT frame which is UL operating temperature code T4-135°C. For 120 volt motor, see page 3.32, item 34, special armature voltage. See page 4.19 for standard explosionproof outlines. A thermostat with a normally closed contact is included as standard.

For Class II, Groups E, F, and G (Division 1 & 2), UL listed motors in frames CD180AT-CD409AT, add \$675 GO-2X. For TEAO explosionproof, add \$6612 GO-2X (CD407AT and CD409AT frames only).

For CSA approval on explosionproof motors, add as follows:

Frame	GO-2X	Frame	GO-2X
CD180AT	\$669	CD320AT	\$1338
CD210AT	\$936	CD400AT	\$1524
CD280AT	\$1071		

NOTE: Special conduit box and nameplates are required on CSA approved motors.

Motor Pricing

ACCESSORIES: Explosion proof motors are available only with the accessories listed below. An accessory mounting face is available. Contact **Wolong** for suitability and availability of accessory mounting options.

Brakes

Explosion proof brake. Refer to **Wolong**.

NOTE: These are not available with a thru shaft.

Breather Drains

Drain holes are normally selected to provide drainage of moisture that might collect at the lowest point of the motor. Explosion proof enclosures, as standard, do not have drain holes. The breather drain is approved for this enclosure when properly maintained after installation. Add \$510 GO-2X per drain.

Precision Balance

Not available on explosionproof motors.

Shaft Extensions

Oversize shaft extensions are not available on explosion proof motors.

Space Heaters

For heaters installed and leads brought out through the motor conduit box, add \$546 GO-2X.

Tachometers

For explosionproof (Class 1, Group D, Class II, Groups E, F, and G) motor-mounted tachometer, add as follows:

Wolong will not mount non-explosion proof tachometers on explosion proof motors.

	GO-2X
BC42 (50V/1000RPM) or (100V/1000RPM)	\$10400
Dynapar X25 (5VDC to 15 VDC Max) (240, 512, 600, 1024, 1200, 2048 PPR) Only suitable for installation in Class 1, Group D environments	\$4080
For other options, refer to GE.	
Mounting kit only for BC tach for explosionproof motor (included as part of tachometer price). Kit includes adapter, coupling, stub shaft, and mounting bracket for BC tachometers. Mounting kit is assembled to motor	\$1806
For mounting only of customer-supplied explosionproof tachometer. This includes coupling, stub shaft, mounting bracket, and assembly of tachometer.	\$3269

Other accessories are available. Accessories and modifications may be added only when they do not affect the explosionproof features of the motor. All accessories must meet or exceed environment class and group requirements as defined by the National Electrical Code and Underwriters' Laboratories. Refer to **Wolong**.

Note: A double shaft extension is not available on explosion-proof BC tachometers.

The motors described in this section have been listed by Underwriters' Laboratories for application in hazardous locations of the classes and groups referred to.

Explosionproof and Dust-Ignitionproof Motors

Class F Insulation
For Continuous Operation in 40°C Ambient

Purged/Totally Enclosed Separately Ventilated for Hazardous Locations

Type CD
Shunt Wound

Class I

Section 501-8 of the National Electrical Code permits the use of enclosed separately ventilated motors with air ducted-in, air ducted-out ventilation in Class I, Division 1 or 2 locations when installation and operation conform to certain requirements. Motors must be air-purged with a source of clean air and have the control arranged to prevent energization of the machine, until ventilation has been established and the enclosure has been purged with at least 10 volumes of air. Protective devices such as a thermostat must be utilized on the motor to detect any increase in temperature of the motor beyond the design limits, and the control must be arranged to automatically de-energize the equipment. Motor leads must be sealed at the frame exit (see Section 501-5 of the National Electrical Code). Auxiliary equipment such as a conduit box, tachometer, and other auxiliary devices mounted on the motor must be of the explosionproof type for Division 1 locations. Sealed leads and standard conduit box may be used for Division 2 locations.

Class II

Section 502-8 of the National Electrical Code permits the use of enclosed separately ventilated motors with air ducted-in, air ducted-out ventilation for use in Class II, Division 1 and 2 locations, provided that the maximum surface temperatures shall not exceed 120°C, (248°F). Auxiliary equipment such as a conduit box, tachometer, and other auxiliary devices mounted on the motor must be of the explosionproof type for Division 1 locations. Sealed leads and standard conduit box may be used for Division 2 locations.

Separate ventilation in hazardous locations is not available in CD180AT.

SUMMARY OF MOTOR REQUIREMENTS FOR SEPARATELY VENTILATED MOTORS IN HAZARDOUS LOCATION					
	MOTOR LEADS	CONDUIT BOX	TACHOMETERS	SPACE HEATERS	AUXILIARY DEVICES
CLASS I					
DIVISION 1	SEALED	XP	XP	LOW TEMP	XP
DIVISION 2	SEALED	STANDARD	XP	LOW TEMP	XP
CLASS II					
DIVISION 1	SEALED	XP	XP	LOW TEMP	XP
DIVISION 2	SEALED	STANDARD	XP	LOW TEMP	XP
XP=Explosion proof rated for hazardous location where motor is used					

WARNING: Enclosed separately ventilated motors supplied for use in a hazardous location do not have an Underwriters' listing and are not explosionproof. Articles 501-8 and 502-8 of the National Electrical Code governing the installation of motors in Class I and Class II locations assign approval of the installation to "the authority having jurisdiction" (see Article 100 - Definitions of the NEC). Therefore, it is the responsibility of the customer to be familiar with the NEC and the local jurisdictional requirements, and to determine that the motor selection (including possibly permissible alternative ventilation systems or accessories) is "acceptable to the authority having jurisdiction."

Motor Pricing

Papermill Duty

Class F Insulation

For Continuous Operation in 40°C Ambient

Totally Enclosed Nonventilated

Motor Pricing

Wolong produces DC motors designed specifically for papermill applications. These ratings are available in Splash proof Fully Guarded Separately Ventilated (SPFG-SV) or Totally Enclosed Nonventilated (TENV) enclosures. The pricing includes standard papermill features listed below. Other modifications may be specified. Refer to the Accessories and Modifications section for price adders.

Frames are listed for Class F temperature rise and Class B temperature rise. Class F rise motors are rated at 1.0 Service Factor (SF) and 150% occasional overload. Class B rise motors are rated at 1.0 SF and 200% occasional overload, Class F rise at 1.15 SF and 150% occasional overload. Class F or Class B rise must be specified at the time of order. Other combinations available and must be specified at the time of order.

All frames listed include 40°C ambient, continuous duty, and 240/120V or 300/150V shunt field. Voltage must be specified at the time of order. Ratings up to and including 1250 HP are 500V armature. Ratings 1500 HP and above are 700V armature.

Refer to GE for backstand or unwind applications.

Standard papermill features include:

- Transparent cover (Lexan® or equivalent) located on the conduit box side of the motor.
- Cast iron endshields on frames CD210AT-CD508AT
- Shaft grounding brush
- One normally opened and one normally closed thermostat
- Drive end labyrinth seal
- Oversize conduit box
- Waterproof conduit box on frames CD218AT-CD5010AY
- Special brushes
- Splashproof Fully Guarded Separately Ventilated (SPFG-SV) or Totally Enclosed Nonventilated (TENV) enclosure
- Air entry in drive end on separately ventilated machine

PRICES - 500 Volts (Type C Power Supply^②)

Suitable for constant torque to 5% of base speed

HP	Base Speed RPM	Rated Top Speed RPM	F Rise		B Rise		Dim. Pg.
			Basic List Price* GO-2A	Frame ④	Basic List Price* GO-2A	Frame ④	
				500V		500V	
2	1750	2300	\$7170	218AT	\$8186	218AT	4.10
	1150	2000	\$8540	218AT	\$9900	219AT	4.10
3	1750	2300	\$8402	218AT	\$9726	218AT	4.10
	1150	2000	\$10454	219AT	\$12486	258AT	4.10
5	1750	2300	\$11758	2110AT	\$13922	2110AT	4.10
	1150	2000	\$14062	258AT	\$16688	259AT	4.10
7.5	1750	2300	\$14140	259AT	\$16786	259AT	4.10
	1150	2000	\$17010	288AT	\$20374	327AT	4.10
10	1750	2300	\$16516	327AT	\$19756	327AT	4.10
	1150	2000	\$19038	328AT	\$22908	328AT	4.10
15	1750	2300	\$19440	328AT	\$23410	328AT	4.10
	1150	2000	\$23292	366AT	\$28026	368AT	4.15

* Basic list price applies to frames listed. Refer to Modification section for appropriate list price addition(s).

② For suitability of operation with rectified power supplies, see page 2.29.

④ Standard shaft for frames CDL182AT-CD5010AY, CD6000, and CD6100 is suitable for belt drive or direct coupling (within limits given in Application Section). Frames CD6200, CD6700, CD6800, and CD6900 are suitable for direct drive only.

Splashproof Fully Guarded Self Ventilated (SPFG-SV) (Frame CD328AT shown at right.)

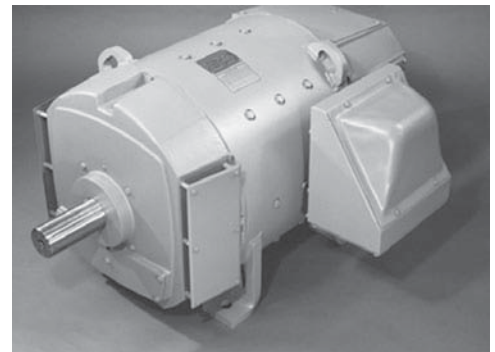

Papermill Duty

Class F Insulation

Type C Power Supply[Ⓣ]

For Continuous Operation in 40°C Ambient

Splashproof Fully Guarded
Separately Ventilated

PRICES - 500 Volts

Suitable for constant torque to 5% of base speed

HP	Base Speed RPM	Rated Top Speed RPM	F Rise, 150% O.L.		Dim. Pg.	B Rise, 200% O.L.		Dim. Pg.
			Basic List Price* GO-2A	Frame ④		Basic List Price* GO-2A	Frame ④	
7.5	1750	2300	\$9724	218AT	4.10	\$11220	218AT	4.10
	1150	2000	\$11048	2110AT	4.10	\$13066	258AT	4.10
	850	1700	\$12604	259AT	4.10	\$14774	⑩	
	650	1600	\$14868	288AT	4.10	\$17492	288AT	4.10
	500	1500	\$16924	327AT	4.10	\$20060	327AT	4.10
	400	1200	\$20554	328AT	4.10	\$24398	328AT	4.10
	300	900	\$23542	368AT	4.15	\$28134	368AT	4.15
10	1750	2300	\$10604	219AT	4.10	\$12320	2110AT	4.10
	1150	2000	\$12280	258AT	4.10	\$14366	⑩	
	850	1700	\$14358	287AT	4.10	\$16854	327AT	4.10
	650	1600	\$16654	327AT	4.10	\$19724	328AT	4.10
	500	1500	\$18918	328AT	4.10	\$23352	365AT	4.15
	400	1200	\$23082	329AT	4.10	\$27558	329AT	4.10
	300	900	\$26682	368AT	4.15	\$32058	368AT	4.15
250	750	\$29332	368AT	4.15	\$35372	⑩		
15	1750	2300	\$12254	258AT	4.10	\$14336	259AT	4.10
	1150	2000	\$14616	288AT	4.10	\$17176	288AT	4.10
	850	1700	\$16588	327AT	4.10	\$19642	327AT	4.10
	650	1600	\$20356	327AT	4.10	\$24152	328AT	4.10
	500	1500	\$23364	329AT	4.10	\$27910	329AT	4.10
	400	1200	\$27118	365AT	4.15	\$32604	⑩	
	300	900	\$32202	366AT	4.15	\$38958	407AT	4.15
250	750	\$35712	409AT	4.15	\$43346	⑩		
20	1750	2300	\$13522	259AT	4.10	\$15922	259AT	4.10
	1150	2000	\$16276	327AT	4.10	\$19250	327AT	4.10
	850	1700	\$18976	328AT	4.10	\$22626	328AT	4.10
	650	1600	\$23256	328AT	4.10	\$27778	328AT	4.10
	500	1500	\$26674	329AT	4.10	\$32048	329AT	4.10
	400	1200	\$31318	366AT	4.15	\$37854	407AT	4.15
	300	900	\$36808	407AT	4.15	\$44718	409AT	4.15
250	750	\$41662	⑩		\$50784	⑩		
25	1750	2300	\$15210	287AT	4.10	\$17920	288AT	4.10
	1150	2000	\$18072	328AT	4.10	\$21496	328AT	4.10
	850	1700	\$21840	328AT	4.10	\$26006	328AT	4.10
	650	1600	\$25890	329AT	4.10	\$31070	⑩	
	500	1500	\$29818	368AT	4.15	\$35980	407AT	4.15
	400	1200	\$35056	368AT	4.15	\$42528	407AT	4.15
	300	900	\$40762	409AT	4.15	\$49658	⑩	
250	750	\$47062	⑩		\$57534	⑩		
30	1750	2300	\$16330	288AT	4.10	\$19320	288AT	4.10
	1150	2000	\$19530	328AT	4.10	\$23320	328AT	4.10
	850	1700	\$23704	329AT	4.10	\$28336	329AT	4.10
	650	1600	\$27982	366AT	4.15	\$33684	368AT	4.15
	500	1500	\$32518	407AT	4.15	\$39354	407AT	4.15
	400	1200	\$38088	407AT	4.15	\$46318	⑩	
	300	900	\$45406	⑩		\$55466	⑩	
250	750	\$55566	327AT	4.10	\$68166	⑩		
40	1750	2100	\$18490	327AT	4.10	\$22020	327AT	4.10
	1150	2000	\$23230	328AT	4.10	\$27744	329AT	4.10
	850	1700	\$27240	366AT	4.15	\$32756	368AT	4.15
	650	1600	\$32166	368AT	4.15	\$38916	407AT	4.15
	500	1500	\$37752	407AT	4.15	\$45896	504AT	4.15
	400	1200	\$44002	409AT	4.15	\$53708	506AT	4.15
300	900	\$52912	409AT	4.15	\$64846	508AT	4.15	

HP	Base Speed RPM	Rated Top Speed RPM	F Rise, 150% O.L.		Dim. Pg.	B Rise, 200% O.L.		Dim. Pg.
			Basic List Price* GO-2A	Frame ④		Basic List Price* GO-2A	Frame ④	
50	1750	2100	\$20538	328AT	4.10	\$24580	328AT	4.10
	1150	2000	\$26010	329AT	4.10	\$31220	368AT	4.15
	850	1700	\$30790	368AT	4.15	\$37194	407AT	4.15
	650	1600	\$36216	368AT	4.15	\$43978	504AT	4.15
	500	1500	\$42508	504AT	4.15	\$51842	504AT	4.15
	400	1200	\$49780	409AT	4.15	\$60932	506AT	4.15
	300	900	\$59586	508AT	4.15	\$73190	508AT	4.15
60	1750	2100	\$23736	L328AT	4.10	\$28352	329AT	4.10
	1150	2000	\$29022	368AT	4.15	\$34984	368AT	4.15
	850	1700	\$34288	368AT	4.15	\$41568	407AT	4.15
	650	1600	\$40132	407AT	4.15	\$48872	504AT	4.15
	500	1500	\$47472	504AT	4.15	\$58046	⑩	
	400	1200	\$55198	506AT	4.15	\$67704	508AT	4.15
	300	900	\$65944	506AT	4.15	\$81136	⑩	
250	750	\$77300	508AT	4.15	\$96294	⑩		
75	1750	2100	\$27010	329AT	4.10	\$32470	368AT	4.15
	1150	2000	\$33262	368AT	4.15	\$40248	368AT	4.15
	850	1700	\$38628	407AT	4.15	\$46992	409AT	4.15
	650	1600	\$46006	504AT	4.15	\$56216	504AT	4.15
	500	1500	\$53952	506AT	4.15	\$66146	508AT	4.15
	400	1200	\$62646	506AT	4.15	\$77016	5010AY	4.15
	300	900	\$77426	508AT	4.15	\$95320	⑩	
250	750	\$86770	⑩		\$106720	⑩		
100	1750	2000	\$32640	368AT	4.15	\$39506	368AT	4.15
	1150	2000	\$39564	407AT	4.15	\$48160	409AT	4.15
	850	1700	\$45532	409AT	4.15	\$55622	409AT	4.15
	650	1600	\$54106	506AT	4.15	\$66340	506AT	4.15
	500	1500	\$63198	508AT	4.15	\$77704	508AT	4.15
	400	1200	\$76238	5010AY	4.15	\$93834	5010AY	4.15
	300	900	\$90440	5010AY	4.15	\$112720	6058	4.29
250	750	\$100600	6062	4.29	\$124006	6062	4.29	
125	1750	2000	\$37756	368AT	4.15	\$45902	407AT	4.15
	1150	2000	\$45532	409AT	4.15	\$55622	409AT	4.15
	850	1700	\$52470	506AT	4.15	\$64294	506AT	4.15
	650	1600	\$61530	506AT	4.15	\$75620	506AT	4.15
	500	1500	\$75104	508AT	4.15	\$92418	508AT	4.15
	400	1200	\$86540	5010AY	4.15	\$106714	5010AY	4.15
	300	900	\$101472	6062	4.29	\$125378	5010AY	4.15
250	750	\$113594	407AT	4.15	\$140248	⑩		
150	1750	2000	\$42724	407AT	4.15	\$52110	L409AT	4.15
	1150	2000	\$51622	409AT	4.15	\$63234	506AT	4.15
	850	1700	\$58722	506AT	4.15	\$72108	506AT	4.15
	650	1600	\$69306	506AT	4.15	\$85170	508AT	4.15
	500	③	\$84074	508AT	4.15	\$103630	5010AY	4.15
	400	③	\$94652	5010AY	4.15	\$116854	5010AY	4.15
	300	③	\$113594	6062	4.29	\$140248	6062	4.29
250	500	\$126640	⑩		\$156556	⑩		

* Basic list price applies to frames listed. Prices include standard papermill features listed on page 2.26. Refer to Modification section for other accessories and modifications.

② For suitability of operation with rectified power supplies, see page 2.29.

④ Standard shaft for frames CDL182AT-CD5010AY, CD6000, and CD6100 is suitable for belt drive or direct coupling (within limits given in Application Section Frames CD 6200, CD6700, CD6800, and CD6900 are suitable for direct drive only.

⑩ Refer to Wolong for frame.

ⓐ Top speed; Class F rise=1500, Class B rise=1000

ⓑ Top speed; Class F rise=1200, Class B rise=1000

ⓒ Top speed; Class F rise=900, Class B rise=800

Motor Pricing

Papermill Duty

Class F Insulation

Type C Power Supply^②

For Continuous Operation in 40°C Ambient

Splashproof Fully Guarded
Separately Ventilated

Motor Pricing

PRICES - 500 Volts

Suitable for constant torque to 5% of base speed

HP	Base Speed RPM	Rated Top Speed RPM	F Rise, 150% O.L.		Dim. Pg.	B Rise, 200% O.L.		Dim. Pg.
			Basic List Price* GO-2A	Frame ④		Basic List Price* GO-2A	Frame ④	
200	1750	2000	\$52876	L409AT	4.15	\$124802	L409AT	4.15
	1150	1800	\$62730	506AT	4.15	\$77120	506AT	4.15
	850	1700	\$71492	506AT	4.15	\$87904	5010AY	4.15
	650	1300	\$83832	508AT	4.15	\$104458	6058	4.29
	500	1500	\$99688	6062	4.29	\$122864	6062	4.29
	400	1200	\$113752	6165	4.30	\$140446	6169	4.30
	300	⑩	\$133300	6164	4.30	\$164882	6169	4.30
	250	750	\$150340	504AT	4.15	\$186182	⑩	
250	1750	1900	\$63892	504AT	4.15	\$78572	506AT	4.15
	1150	1700	\$69030	506AT	4.15	\$92326	508AT	4.15
	850	1600	\$83970	5010AY	4.15	\$109502	5010AY	4.15
	650	1600	\$94266	5010AY	4.15	\$117500	6062	4.29
	500	1500	\$117884	6062	4.29	\$145610	6062	4.29
	400	1200	\$131260	6169	4.30	\$162332	6169	4.30
	300	900	\$152434	6259	4.31	\$188798	6262	4.31
	250	750	\$171910	⑩		\$213144	⑩	
300	1150	1600	\$87044	508AT	4.15	\$107344	5010AY	4.15
	850	1500	\$96966	5010AY	4.15	\$119746	5010AY	4.15
	650	1500	\$107816	6062	4.29	\$133026	6062	4.29
	500	1300	\$128386	6160	4.30	\$158738	6160	4.30
	400	1200	\$146614	6169	4.30	\$181524	6169	4.30
	300	900	\$169994	6262	4.31	\$210748	6262	4.31
	250	750	\$191980			\$238232		
	400	1150	1500	\$113570	5010AY	4.15	\$141632	6058
850		1500	\$124420	6062	4.29	\$153782	6160	4.30
650		1400	\$133060	6160	4.30	\$164582	6164	4.30
500		1200	\$148810	6259	4.31	\$184270	6262	4.31
400		1000	\$173342	6262	4.31	\$214934	6266	4.31
300		750	\$207380	6266	4.31	\$257482	6271	4.31
250		710	\$228790			\$284244		
500		1150	1500	\$145010	6058	4.29	\$179520	6157
	850	1400	\$153784	6160	4.30	\$190486	6160	4.30
	650	1200	\$160258	6164	4.30	\$198578	6164	4.30
	500	1000	\$173656	6262	4.31	\$215326	6262	4.31
	400	1000	\$207514	6266	4.31	\$257648	6275	4.31
	300	750	\$235682	6271	4.31	\$292794	6779	4.32
	250	710	\$263426			\$327476		
	600	1150	1500	\$208634	6066	4.29	\$238882	6168
850		1300	\$210586	6173	4.30	\$241126	6268	4.31
650		1200	\$229898	6268	4.31	\$263336	6270	4.31
500		1000	\$255938	6275	4.31	\$293282	6275	4.31
400		1000	\$273604	6280	4.31	\$313596	6779	4.32
300		750	\$298068	6881	4.33	\$341694	6881	4.33
250		710	\$334526			\$383620		
700		1150	1300	\$231134	6168	4.30	\$264758	6268
	850	1200	\$233218	6173	4.30	\$267154	6270	4.31
	650	1000	\$258230	6270	4.31	\$295918	6275	4.31
	500	1000	\$280750	6275	4.31	\$322072	6779	4.32
	400	1000	\$298664	6881	4.33	\$342376	6881	4.33
	300	750	\$333464	6887	4.33	\$382396	6887	4.33
	250	710	\$374726	⑩		\$429850	⑩	

* Basic list price applies to frames listed. Prices include standard papermill features listed on page 2.26. Refer to Modification section for other accessories and modifications.

② For suitability of operation with rectified power supplies, see page 2.29.

④ Standard shaft for frames CDL182AT-CD5010AY, CD6000, and CD6100 is suitable for belt drive or direct coupling (within limits given in Application Section Frames CD 6200, CD6700, CD6800, and CD6900 are suitable for direct drive only.

⑩ Refer to Wolong for frame.

④ Top Speed; Class F=900, Class B=600

PRICES - 500 Volts

Suitable for constant torque to 5% of base speed

HP	Base Speed RPM	Rated Top Speed RPM	F Rise, 150% O.L.		Dim. Pg.	B Rise, 200% O.L.		Dim. Pg.
			Basic List Price* GO-2A	Frame ④		Basic List Price* GO-2A	Frame ④	
800	1150	1250	\$254218	6173	4.30	\$291560	6268	4.31
	850	1000	\$256600	6270	4.31	\$294298	6270	4.31
	650	1000	\$282316	6275	4.31	\$323872	6275	4.31
	500	1000	\$304214	6280	4.31	\$348760	6779	4.32
	400	1000	\$324882	6881	4.33	\$372528	6887	4.33
	300	750	\$362808	6887	4.33	\$416144	6985	4.34
	250	710	\$406226	⑩		\$466076	⑩	
	900	1150	1250	\$283096	6268	4.31	\$324770	6268
850		1000	\$285268	6270	4.31	\$327266	6270	4.31
650		1000	\$305916	6275	4.31	\$350718	6774	4.32
500		1000	\$325874	6779	4.32	\$373664	6779	4.32
400		1000	\$346346	6887	4.33	\$397214	6887	4.33
300		750	\$386838	6985	4.34	\$443778	6985	4.34
250		710	\$439002	⑩		\$503666	⑩	
1000		1150	1250	\$307034	6268	4.31	\$352004	6776
	850	1000	\$308656	6270	4.31	\$354164	6778	4.32
	650	1000	\$328104	6774	4.32	\$376232	6785	4.32
	500	1000	\$350180	6881	4.33	\$401620	6896	4.33
	400	1000	\$370412	6887	4.33	\$424888	6996	4.34
	300	750	\$414450	6985	4.34	\$475430	6999	4.34
	250	710	\$470502	6991	4.34	\$539892	⑩	
	1250	1150	1150	\$365570	6776	4.32	\$419320	⑩
850		1000	\$367448	6778	4.32	\$421480	6890	4.33
650		1000	\$387170	6785	4.32	\$444160	6896	4.33
500		1000	\$407148	6896	4.33	\$467136	6996	4.34
400		900	\$431396	6996	4.33	\$494940	6999	4.34
300		750	\$481984	⑩		\$553096	⑩	

PRICES - 700 Volts

(3 Phase, 6 Controlled Pulse Power Supply^②)

Suitable for constant torque to 5% of base speed

HP	Base Speed RPM	Rated Top Speed RPM	F Rise, 150% O.L.		Dim. Pg.	B Rise, 200% O.L.		Dim. Pg.	
			Basic List Price* GO-2A	Frame ④		Basic List Price* GO-2A	Frame ④		
									700V
1500	850	1000	\$421084	6876	4.33	\$483060	6986	4.34	
	650	900	\$443962	6881	4.33	\$509370	6990	4.34	
	500	850	\$467074	6996	4.34	\$535948	6999	4.34	
	450	810	\$480620	6999	4.34	\$551524	⑩		
	400	770	\$494164	6999	4.34	\$567102	6999	4.34	
	350	720	\$535180	6991	4.34	\$614268	⑩		
	1750	850	960	\$473302	6881	4.33	\$543112	⑩	
		650	900	\$498796	6990	4.34	\$572428	6996	4.34
500		800	\$524814	6996	4.34	\$602348	6999	4.34	
450		760	\$649850	6999	4.34	\$746140	⑩		
2000	850	900	\$590782	6896	4.33	\$678214	6896	4.33	
	650	840	\$628102	6996	4.34	\$721132	6996	4.34	
	500	750	\$677922	6999	4.34	\$778424	6999	4.34	

NOTE: Motors rated 1000HP and above may need external reactance (supplied by customer) included in the circuit to limit ripple current when powered by rectified power supplies (see page 2.29).

Power Supplies

Motor Operation from Rectified Power Supplies

Motors are suitable for operation with MG sets or with the rectified power supplies described below:

a. Single-phase, full wave, 60 cycle

(Power Supply Identification K)

Only motors rated 7.5 HP or less, 180 Volts, are suitable for this type of power supply. These ratings do not require an external reactor. For AC supplies other than 230 volts, 60 cycle, refer to **Wolong**.

b. Three-phase modified, 60 cycle

(Power Supply Identification D)

This power supply has three controlled rectifiers and three uncontrolled rectifiers plus a free-wheeling rectifier. It produces the three pulses per cycle. Motors rated 250 HP or less in frames CD5010AY and below may be used on this type of power supply. No external reactors are required for motors in frames CD5010AY and below, although improved operation at low speeds may be obtained on frames CD365AT-CD5010AY using a reactor. The 240 volt motors are based on 230 volt, three-phase, 60 cycle AC voltage applied to the rectifier bridge, while the 500 volt motors are based on 460 volt, three-phase, 60-cycle AC voltage applied to the rectifier bridge.

c. Three-phase, full wave 60 cycle

(Power Supply Identification C)

This power supply has six controlled rectifiers and produces six pulses per cycle. The 240 volt motors are based on 230 volt, three-phase, 60-cycle AC voltage applied to the rectifier bridge, while the 500 volt motors are based on 460 volt, three-phase, 60-cycle AC voltage applied to the rectifier bridge. Motors in AC voltage CD6000-CD6900 are suitable only for operations from six-controlled, 3 leg power supplies.

d. Three-phase, full wave other than 60-cycle, 240 volt DC (230 volt AC) or 500 volt DC (460 volt AC)

Power supplies of this type require identification as follows:

M/N F-V-H-L where:

M = a digit indicating total pulses per cycle.

N = a digit indicating controlled pulses per cycle.

F = free wheeling (this letter appears only if free wheeling is used).

V = three digits indicating nominal line-to-line AC voltage to the rectifier.

H = two digits indicating input frequency in hertz

L = one, two, or three digits indicating the series inductance in millihenries (may be zero) to be added externally to the motor armature circuit.

If input frequency is 60 hertz and no series inductance is added externally to the motor armature circuit, these quantities need not be indicated and shall be permitted to be omitted from the identification of the power supply. However, if one of these qualities is indicated, then both shall appear to avoid confusion (NEMA MG1-2009, part 10.61.2).

For other types of power supplies, refer to **Wolong**.

Standard shunt field voltages are as shown under field voltage modification. (Refer to the Modifications Section Item 34)

Reactors

All DC motor ratings in CD6000-CD6900 frames operating on twelve pulse, three phase rectified power supplies and all ratings in CD6000-CD6200 frames operating on less than twelve pulse rectified power supplies do not require external inductance.

DC motor ratings in CD6700-CD6900 frames operating on less than twelve pulse rectified power supplies may require external inductance to limit the armature circuit current ripple to assure acceptable commutation and long brush, commutator and bearing life. Armature current ripple is determined by power supply type, ration of DC to AC line voltage, and total circuit inductance. For DC motors in CD6700-CD6900 frames rated at the following horsepower and speed combinations or for any rating in CD6700-CD6900 frames having an armature circuit inductance of 0.2mH and less, **we** recommend a 0.5mH external reactor. **Our** experience indicates that this is especially true of applications where the motor is operated at rated load and speed or higher for extended periods.

Horsepower	Base Speed (RPM)
1000-1250	850 and above
1500	650 and above
1750-3000	500 and above

When external reactance is used, it should be installed in series with the A1 leads of the motor.

The reactor should be sized to have the following:

Continuous and overload DC rating equal to the motor rating.

AC RMS current rating equal to 25% of motor DC rated current for large variance between AC supply and rectified DC voltage.

Frequency rating equal to 360 Hz

Enclosure equal to NEMA 1 or as suitable for environment.

Following is one source for the reactors described above:

Transformer Engineering Corporation

2550 Brookpark Road, Cleveland, Ohio 44134

Ph. 1-(216)-741-5282

DC Current	Design	%AC RMS Amps of DC Amps
1000	TR-15902	25
1500	TR-15903	25
2000	TR-14711	25
2500	TR-15904	12.5
3000	TR-15905	12.5
3500	TR-15906	12.5

Accessories and Modifications

CD180AT through CD6900

Index

Item	Description	Page	Item	Description	Page
1	Accessory Mounting	3.2	20	Overload-Maximum Load	3.17
2	Air Pressure Switch	3.2	21	Pump Motors	3.18
3	Altitude	3.2	22	Seals, Drive End Shaft	3.18
4	Ambient Temperature	3.2	23	Severe Mechanical Duty	3.19
5	Balance, Mechanical	3.2	24	Shaft Extensions	3.19
6	Bases	3.3	25	Shaft Grounding Brush	3.21
7	Bearings	3.4	26	Space Heaters.	3.21
8	Brakes.	3.4	27	Speed Limit Device	3.21
9	Canadian Standards Association (CSA)	3.8	28	Speed Range Greater than Standard by Field Control	3.22
10	CE Mark, European Standards	3.8	29	Tachometer Generators.	3.24
11	Conduit Boxes.	3.9	30	Terminal Board in Conduit Box.	3.29
12	Covers.	3.10	31	Tests and Curves	3.30
13	Crane Motors	3.11	32	Temperature Detectors	3.31
14	Customer-Supplied Material	3.11	33	Vertical Mounting.	3.31
15	Drains.	3.12	34	Voltages	3.32
16	Enclosures	3.13	35	Warranty Extension	3.32
17	Endshields	3.15	36	Windings, Stabilized Shunt, Compound or Series	3.33
18	Export Boxing	3.17	37	Mod Shop Pricing	3.34
19	Grease and Fittings	3.17			

Accessories and
Modifications

Accessories and Modifications

CD180AT through CD6900

Accessories and Modifications

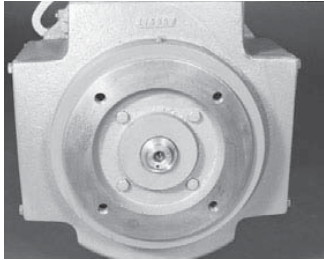
ITEM	DESCRIPTION												
1	<p>ACCESSORY MOUNTING The accessory mounting face is standard on all CD180AT-CD6900 frames, permitting the ease of adding a variety of accessories, including tachometers and speed limit devices. When accessories are not specified, the accessory mounting face and shaft extension are protected by a solidly attached cover that can be removed easily. (Outlines on pages 4.48 and 4.49)</p> <p>On TEFC CD180AT and CD210AT frames and all explosion-proof frames, accessory mounting face is <u>not</u> available.</p>												
	 <p>Accessory Mounting—Standard motor frames CDL182AT-CD5010AY are constructed to allow the addition of tachometers or speed limit devices.</p>												
2	<p>AIR PRESSURE SWITCH Differential air pressure switch (1-form-C contact, 10amp, 120V, 60 Hz) Used to indicate positive pressure into the motor from an external source. CAUTION: Switch must be mounted vertical.</p>												
	<table border="0"> <tr> <td style="text-align: right;"><u>List Price Addition</u></td> <td></td> </tr> <tr> <td style="text-align: right;">Blower Ventilated/Separately Ventilated Motor</td> <td style="text-align: right;">\$2782</td> </tr> <tr> <td style="text-align: right;">Totally Enclosed Air-To-Air Cooled (Internal air circuit only)</td> <td style="text-align: right;">\$3650</td> </tr> </table>	<u>List Price Addition</u>		Blower Ventilated/Separately Ventilated Motor	\$2782	Totally Enclosed Air-To-Air Cooled (Internal air circuit only)	\$3650						
<u>List Price Addition</u>													
Blower Ventilated/Separately Ventilated Motor	\$2782												
Totally Enclosed Air-To-Air Cooled (Internal air circuit only)	\$3650												
3	<p>ALTITUDE Motors and generators are suitable for operation at altitudes from sea level to 3,300 feet above sea level. For other conditions, refer to GE or frame sizes.</p>												
	<table border="1" style="margin-left: auto; margin-right: auto;"> <thead> <tr> <th rowspan="2">Altitude</th> <th colspan="2">List Price Additions</th> </tr> <tr> <th>Frames CD5010AY</th> <th>Frames CD6000 and Above</th> </tr> </thead> <tbody> <tr> <td style="text-align: center;">3,301-8,800 Ft.</td> <td style="text-align: center;">Add 15%</td> <td style="text-align: center;">Add 10%</td> </tr> <tr> <td style="text-align: center;">8,801-15,000 Ft.</td> <td style="text-align: center;">Add 22%</td> <td style="text-align: center;">Add 15%</td> </tr> </tbody> </table>	Altitude	List Price Additions		Frames CD5010AY	Frames CD6000 and Above	3,301-8,800 Ft.	Add 15%	Add 10%	8,801-15,000 Ft.	Add 22%	Add 15%	
Altitude	List Price Additions												
	Frames CD5010AY	Frames CD6000 and Above											
3,301-8,800 Ft.	Add 15%	Add 10%											
8,801-15,000 Ft.	Add 22%	Add 15%											
4	<p>AMBIENT TEMPERATURE Standard motor is suitable for operation in an ambient temperature of 0°C to 40°C. For ambient temperature greater than 40°C, see List Price adder at right: Refer to Wolong for frame size. Refer to Wolong for applications in an ambient temperature higher than 65°C or lower than 0°C.</p>												
	<table border="1" style="margin-left: auto; margin-right: auto;"> <thead> <tr> <th colspan="3">List Price Additions</th> </tr> <tr> <th>Ambient</th> <th>500 HP and Less</th> <th>600 HP and above</th> </tr> </thead> <tbody> <tr> <td style="text-align: center;">41°C-60°C</td> <td style="text-align: center;">Add 20%</td> <td style="text-align: center;">Add 10%</td> </tr> <tr> <td style="text-align: center;">61°C-65°C</td> <td style="text-align: center;">Add 25%</td> <td style="text-align: center;">Contact GE</td> </tr> </tbody> </table>	List Price Additions			Ambient	500 HP and Less	600 HP and above	41°C-60°C	Add 20%	Add 10%	61°C-65°C	Add 25%	Contact GE
List Price Additions													
Ambient	500 HP and Less	600 HP and above											
41°C-60°C	Add 20%	Add 10%											
61°C-65°C	Add 25%	Contact GE											
5	<p>BALANCE, MECHANICAL Vibration measurements are made on motor bearing housings. Amplitude is expressed as inches peak-to-peak. Vibration limits for standard and precision balance are for the motor <u>only</u> without any mounted accessory. The same limits can generally be met with motor-mounted blowers, PY, and AN tachometers. Motors with a BC tachometer or a motor-mounted brake will have peak-to-peak amplitudes of 2 times the value shown below. Where vertical mounting is required, it should be specified on the order. (For special run out, refer to GE.)</p> <p>Standard Vibration Limits</p>												
	<table border="0" style="margin-left: auto; margin-right: auto;"> <thead> <tr> <th style="text-align: center;"><u>Maximum NP Rated RPM</u></th> <th style="text-align: center;"><u>Peak-to-Peak Amplitude (inches)</u></th> </tr> </thead> <tbody> <tr> <td style="text-align: center;">3000-4000</td> <td style="text-align: center;">0.0010</td> </tr> <tr> <td style="text-align: center;">1500-2999</td> <td style="text-align: center;">0.0015</td> </tr> <tr> <td style="text-align: center;">1000-1499</td> <td style="text-align: center;">0.0020</td> </tr> <tr> <td style="text-align: center;">0-999</td> <td style="text-align: center;">0.0025</td> </tr> </tbody> </table>	<u>Maximum NP Rated RPM</u>	<u>Peak-to-Peak Amplitude (inches)</u>	3000-4000	0.0010	1500-2999	0.0015	1000-1499	0.0020	0-999	0.0025		
<u>Maximum NP Rated RPM</u>	<u>Peak-to-Peak Amplitude (inches)</u>												
3000-4000	0.0010												
1500-2999	0.0015												
1000-1499	0.0020												
0-999	0.0025												

Accessories and Modifications

CD180AT through CD6900

ITEM	DESCRIPTION													
5 Cont'd	Improved balance vibration limits (applies to listed ratings only). For other speed ranges, refer to GE. Precision balance is not available on CD180AT, CD6000-CD6900 frames, nor explosionproof motors.													
	Frame Size	CD210AT-CD280AT			CD320AT-CD360AT			CD407AT-CD5010AY						
	Precision balance limits at top speed	PEAK-TO-PEAK AMPLITUDE (INCHES)												
		0.0002	0.0003			0.0004								
	MOTORS LIST PRICE													
	Description	Up to \$2500	\$2501 to \$3592	\$3593 to \$5578	\$5579 to \$9748	\$9749 to \$13218	\$13219 to \$23922	\$23923 to \$42136	\$42137 to \$61750	\$61751 to \$98628	\$98629 and up			
List Price Addition														
Precision Balance	Not Available	\$1338	\$1582	\$2094	\$2688	\$3210	\$4564	\$5490	Not Available					
6	BASES For P-Base see Endshields, Page 3.16.													
6a	Standard Sliding Base Sliding bases are suggested as a convenient means for adjusting belt tension or may be used as mounting plates. (For horizontal mounting only – not available for ceiling or sidewall mounting.) (Not available on CD6700 through CD6900 frames)													
6b	Transition Base Transition bases may be used to match the mounting dimensions of another motor which has a larger “D” dimension. (A drawing must be provided at the time of order.) This option is available if, and only if, the shaft height of the older motor is reasonably higher (varies with motor size, but typically greater than 1 inch is sufficient) than the shaft height of the Kinamatic™ motor at the same rating. For horizontal floor mounting only. Refer to Replacement Motors/Mechanically interchangeable section on page 1.7 for additional details. A special shaft extension may be required.													
6c	Sole Plate Sole plates are two (2) flat steel plates to be mounted in concrete by the customer to provide a mounting surface for the motor. Refer to pages 4.63 – 4.65 for outlines.													
	Description	MOTOR LIST PRICE												
		Up to \$2500	\$2501 to \$3592	\$3593 to \$5578	\$5579 to \$9748	\$9749 to \$13218	\$13219 to \$23922	\$23923 to \$42136	\$42137 to \$61750	\$61751 to \$98628	\$98629 to \$157704	\$157704 to \$252288	\$252289 to \$403650	\$403651 and up
	List Price Addition													
	a. Standard Sliding Base	\$316	\$316	\$316	\$540	\$630	\$1216	\$1600	\$2160	\$2860	\$3844	\$6154	Contact GE	
	b. Transition Base	\$700	\$810	\$944	\$1260	\$1700	\$2300	\$3100	\$4160	\$5560	\$7440	\$10022	\$13724	\$18070
	c. Sole Plate	\$630	\$630	\$630	\$870	\$1110	\$1530	\$2090	\$2760	\$3750	\$5026	\$6760	\$9150	\$12300

Accessories and Modifications

Accessories and Modifications

CD180AT through CD6900

Accessories and Modifications

ITEM	DESCRIPTION				
7	BEARINGS (Belted Drive)				
	Standard shaft for frames CD180AT-CD6100 are suitable for either belt drive or direct coupling within the limits given in the application section on page 5.5. Frames CD6200-CD6900 are suitable for direct drive only. Where the maximum radial load at the end of the shaft exceeds the standard limits, oversize ball bearings and roller bearings are available as listed below. Maximum radial loads and speeds for these modifications are given on pages 5.8 – 5.9.				
	OVERSIZE BALL BEARING ON DE*		STANDARD SIZE ROLLER BEARING ON DE		OVERSIZE ROLLER BEARING ON DE*
	CD218-CD2110	Add \$366	CD287AT, CD288AT	Add \$1044	CD287AT, CD288AT Add \$1210
	CD258-CD288	\$468	CD327AT, CD328AT, CD329AT	\$1044	CD327AT, CD328AT, CD329AT \$1210
	CD327-CD328	\$574	CD365AT-CD508AT	\$1732	CD365AT-CD5010AY \$2498
	CD365-CDL407	\$680	CD6000 (Top spd. 1750 RPM)	\$3334	Not available on frames CD180AT, CD210AT, CD258AT, CD259AT, CD6000-CD6900
CD409-CDL409	\$766	CD6100 (Top spd. 1500RPM)	\$3860		
CD504-CDL508	\$892	Not Available on frames CD180AT, CD210AT, CD258AT, CD259AT, CD5010AY, CD6200, CD6700, CD6800, CD6900			
* When an oversize bearing on DE is specified, a standard DE shaft extension will be furnished. However, if also required an oversize DE shaft is available at no additional price.					

8 BRAKES — Refer to Wolong for application of brakes rated above 100% of rated motor torque.
Order must specify AC/DC voltage and frequency, torque rating (Lb. Ft.), enclosure, and orientation with respect to the motor.
Customer is responsible for specifying brake torque rating.
We do not recommend the use of brakes on TEFC Kinamatic motors. When brakes are required, we recommend TEAO enclosures.

8a BRAKES, DISC TYPE

These brakes are applicable for holding service within rating limitations shown in the table on the next page. Where brakes are required for stopping duty, the heat-dissipating capacity may be the determining factor in the brake selection. **Refer to Wolong.**

Brakes are continuously rated and are nonadjustable spring set and electrically released. For brakes of a specific manufacturer, nonlisted capacity, or adjustable or electrically set brakes, refer to **Wolong**. For frames CD6000-CD6900, use floor-mounted brakes.

AC brakes are recommended on disc brake applications wherever possible, especially for those applications where high cycling duty may occur (e.g., on hoist or screw-down applications). Use a brake of standard enclosure with dripproof fully guarded or splashproof fully guarded motors, and on TENV and TEAO motors for applications in ambients containing chips and/or non-abrasive, non-conducting, and non-explosive dusts and coolants.

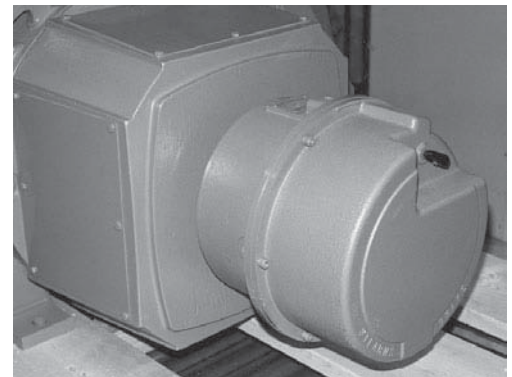

Disc type brakes — Disc type brakes are commonly used on ratings 250 HP and below. The brakes are continuously rated and can be mounted on CD180AT-CD5010AY frames.

Accessories and Modifications

CD180AT through CD6900

ITEM	DESCRIPTION																																																																																																																																		
8a Cont'd	Standard brake features include:																																																																																																																																		
	<ul style="list-style-type: none"> • Class B Insulation • Spring set, electrically released • Manual release with automatic reset • Standard or dust tight waterproof enclosure • CSA certification • 115 or 230 Volt DC coils • Horizontal mounting 	<ul style="list-style-type: none"> • Standard AC brake coils are rated as follows: 	<table border="1"> <thead> <tr> <th></th> <th>Nominal</th> <th>Suitable Range</th> </tr> </thead> <tbody> <tr> <td rowspan="2">60Hz</td> <td>460</td> <td>440-480</td> </tr> <tr> <td>230</td> <td>220-240</td> </tr> <tr> <td rowspan="2">50Hz</td> <td>380</td> <td>360-400</td> </tr> <tr> <td>190</td> <td>180-200</td> </tr> </tbody> </table>				Nominal	Suitable Range	60Hz	460	440-480	230	220-240	50Hz	380	360-400	190	180-200																																																																																																																	
	Nominal		Suitable Range																																																																																																																																
60Hz	460	440-480																																																																																																																																	
	230	220-240																																																																																																																																	
50Hz	380	360-400																																																																																																																																	
	190	180-200																																																																																																																																	
<p>Note: Single voltage coils are supplied on brakes rated 750 lb. ft. and above. Voltage must be specified at time of order.</p>																																																																																																																																			
<p>WARNING:</p> <p>Brake performance and features must be carefully matched to the requirements of the application. Consideration must be given to torque requirements, especially where an overhauling condition exists, as well as thermal capacity, ambient temperature, atmospheric explosion hazards, type of enclosure, power supply characteristics, and other unusual conditions.</p> <p>Improper selection or installation of a brake and/or lack of maintenance may cause brake failure, which can result in damage to property and/or injury to personnel.</p> <p>If injury to personnel could be caused by brake failure, proper safeguards must be provided to ensure safety of personnel.</p>																																																																																																																																			
<table border="1"> <thead> <tr> <th rowspan="4">Lb. Ft. ⁽²⁾</th> <th rowspan="4">Maximum Horizontal Speed (RPM)</th> <th colspan="4">Motor Mounted Brake List Price Addition</th> </tr> <tr> <th colspan="2">AC Coil</th> <th colspan="2">DC Coil</th> </tr> <tr> <th>Standard Enclosure</th> <th>Dust Tight/Waterproof</th> <th>Standard Enclosure</th> <th>Dust Tight/Waterproof</th> </tr> <tr> <th>NEMA 2 IP23</th> <th>NEMA 4 IP54</th> <th>NEMA 2 IP23</th> <th>NEMA 4 IP54</th> </tr> </thead> <tbody> <tr><td>1.5</td><td>3600</td><td>\$1184</td><td>\$1882</td><td>\$1815</td><td>\$2554</td></tr> <tr><td>3</td><td>3600</td><td>\$1248</td><td>\$1980</td><td>\$1903</td><td>\$2808</td></tr> <tr><td>6</td><td>4000</td><td>\$1248</td><td>\$2058</td><td>\$2017</td><td>\$2827</td></tr> <tr><td>10</td><td>4000</td><td>\$1248</td><td>\$2058</td><td>\$2017</td><td>\$2827</td></tr> <tr><td>15</td><td>4000</td><td>\$1316</td><td>\$2125</td><td>\$2085</td><td>\$2894</td></tr> <tr><td>25</td><td>4000</td><td>\$1417</td><td>\$2226</td><td>\$2186</td><td>\$2995</td></tr> <tr><td>35</td><td>4000</td><td>\$1619</td><td>\$2429</td><td>\$2388</td><td>\$3198</td></tr> <tr><td>50</td><td>4000</td><td>\$2024</td><td>\$2833</td><td>\$2793</td><td>\$3602</td></tr> <tr><td>75</td><td>4000</td><td>\$2833</td><td>\$3643</td><td>\$3602</td><td>\$4412</td></tr> <tr><td>105</td><td>4000</td><td>\$3778</td><td>\$4587</td><td>\$4547</td><td>\$5356</td></tr> <tr><td>125</td><td>3600</td><td>\$8703</td><td>\$10052</td><td>\$10814</td><td>\$12163</td></tr> <tr><td>175</td><td>3600</td><td>\$9040</td><td>\$10389</td><td>\$11151</td><td>\$12501</td></tr> <tr><td>230</td><td>3600</td><td>\$9715</td><td>\$11064</td><td>\$11826</td><td>\$13175</td></tr> <tr><td>330</td><td>3600</td><td>\$10524</td><td>\$11873</td><td>\$12636</td><td>\$13985</td></tr> <tr><td>440</td><td>3600</td><td>\$11738</td><td>\$13088</td><td>\$13850</td><td>\$15199</td></tr> <tr><td>500</td><td>1800</td><td>\$18889</td><td>\$20913</td><td>\$22431</td><td>\$24455</td></tr> <tr><td>750</td><td>1800</td><td>\$20913</td><td>\$22937</td><td>\$24455</td><td>\$26479</td></tr> <tr><td>1000</td><td>1800</td><td>\$22937</td><td>\$24961</td><td>\$26479</td><td>\$28503</td></tr> </tbody> </table>						Lb. Ft. ⁽²⁾	Maximum Horizontal Speed (RPM)	Motor Mounted Brake List Price Addition				AC Coil		DC Coil		Standard Enclosure	Dust Tight/Waterproof	Standard Enclosure	Dust Tight/Waterproof	NEMA 2 IP23	NEMA 4 IP54	NEMA 2 IP23	NEMA 4 IP54	1.5	3600	\$1184	\$1882	\$1815	\$2554	3	3600	\$1248	\$1980	\$1903	\$2808	6	4000	\$1248	\$2058	\$2017	\$2827	10	4000	\$1248	\$2058	\$2017	\$2827	15	4000	\$1316	\$2125	\$2085	\$2894	25	4000	\$1417	\$2226	\$2186	\$2995	35	4000	\$1619	\$2429	\$2388	\$3198	50	4000	\$2024	\$2833	\$2793	\$3602	75	4000	\$2833	\$3643	\$3602	\$4412	105	4000	\$3778	\$4587	\$4547	\$5356	125	3600	\$8703	\$10052	\$10814	\$12163	175	3600	\$9040	\$10389	\$11151	\$12501	230	3600	\$9715	\$11064	\$11826	\$13175	330	3600	\$10524	\$11873	\$12636	\$13985	440	3600	\$11738	\$13088	\$13850	\$15199	500	1800	\$18889	\$20913	\$22431	\$24455	750	1800	\$20913	\$22937	\$24455	\$26479	1000	1800	\$22937	\$24961	\$26479	\$28503
Lb. Ft. ⁽²⁾	Maximum Horizontal Speed (RPM)	Motor Mounted Brake List Price Addition																																																																																																																																	
		AC Coil		DC Coil																																																																																																																															
		Standard Enclosure	Dust Tight/Waterproof	Standard Enclosure	Dust Tight/Waterproof																																																																																																																														
		NEMA 2 IP23	NEMA 4 IP54	NEMA 2 IP23	NEMA 4 IP54																																																																																																																														
1.5	3600	\$1184	\$1882	\$1815	\$2554																																																																																																																														
3	3600	\$1248	\$1980	\$1903	\$2808																																																																																																																														
6	4000	\$1248	\$2058	\$2017	\$2827																																																																																																																														
10	4000	\$1248	\$2058	\$2017	\$2827																																																																																																																														
15	4000	\$1316	\$2125	\$2085	\$2894																																																																																																																														
25	4000	\$1417	\$2226	\$2186	\$2995																																																																																																																														
35	4000	\$1619	\$2429	\$2388	\$3198																																																																																																																														
50	4000	\$2024	\$2833	\$2793	\$3602																																																																																																																														
75	4000	\$2833	\$3643	\$3602	\$4412																																																																																																																														
105	4000	\$3778	\$4587	\$4547	\$5356																																																																																																																														
125	3600	\$8703	\$10052	\$10814	\$12163																																																																																																																														
175	3600	\$9040	\$10389	\$11151	\$12501																																																																																																																														
230	3600	\$9715	\$11064	\$11826	\$13175																																																																																																																														
330	3600	\$10524	\$11873	\$12636	\$13985																																																																																																																														
440	3600	\$11738	\$13088	\$13850	\$15199																																																																																																																														
500	1800	\$18889	\$20913	\$22431	\$24455																																																																																																																														
750	1800	\$20913	\$22937	\$24455	\$26479																																																																																																																														
1000	1800	\$22937	\$24961	\$26479	\$28503																																																																																																																														
<p>⁽²⁾ Motor Torque (Lb. Ft.) = $\frac{\text{HP} \times 5252}{\text{Motor base speed (RPM)}}$</p>																																																																																																																																			
<p>Customer is responsible for specifying brake torque rating.</p>																																																																																																																																			

Accessories and Modifications

Accessories and Modifications

CD180AT through CD6900

Accessories and Modifications

ITEM	DESCRIPTION																														
8a Cont'd	<p>OPTIONS: (Prices below in addition to brake price on previous page)</p> <p>BRAKES WITH ACCESSORY MOUNTING</p> <p>When mounting a second accessory (such as a 56 C-face tachometer or a speed limit device) on DPGF, TENV, TEAO, TEAAC or TEWAC motors, a brake with accessory mounting is required. Add as follows: (Exceptions are noted below)</p> <table border="1" style="width: 100%; border-collapse: collapse;"> <thead> <tr> <th style="text-align: center;">Brake Torque Lb. Ft.</th> <th style="text-align: center;">List Price Addition</th> </tr> </thead> <tbody> <tr> <td style="text-align: center;">10-105</td> <td style="text-align: center;">\$3976</td> </tr> <tr> <td style="text-align: center;">125-440</td> <td style="text-align: center;">\$4446</td> </tr> <tr> <td style="text-align: center;">500-1000</td> <td style="text-align: center;">\$4800</td> </tr> </tbody> </table> <p>Note: Only "AN" style tachometers or a speed limit switch can be mounted with a brake on CD180AT frames. Brake with accessory mounting is not required because the brake is mounted on the tach or speed switch.</p> <p>Note: When mounting a brake (up to and including 330 lb. ft.) with a Northstar or Avtron Type AN-DG tach a standard brake can be used. The brake is mounted on the tach.</p> <p>Note: AN-DG tachs will not be mounted outboard a brake.</p> <p>VERTICAL MOUNTING</p> <p>For a brake mounted above the motor on DPGF or TENV motors, add as follows:</p> <table border="1" style="width: 100%; border-collapse: collapse;"> <thead> <tr> <th style="text-align: center;">Brake Torque Lb. Ft.</th> <th style="text-align: center;">List Price Addition</th> </tr> </thead> <tbody> <tr> <td style="text-align: center;">1.5-6</td> <td style="text-align: center;">\$458</td> </tr> <tr> <td style="text-align: center;">10-105</td> <td style="text-align: center;">\$640</td> </tr> <tr> <td style="text-align: center;">125-1000</td> <td style="text-align: center;">\$1132</td> </tr> </tbody> </table> <div style="display: flex; justify-content: space-between;"> <div style="width: 48%;"> <p>BRAKE SPACE HEATER</p> <p>A brake space heater should be specified whenever a heater is required on the motor. For brake space heater, add as follows:</p> <table border="1" style="width: 100%; border-collapse: collapse;"> <thead> <tr> <th style="text-align: center;">Brake Torque Lb. Ft.</th> <th style="text-align: center;">List Price Addition</th> </tr> </thead> <tbody> <tr> <td style="text-align: center;">1.5-105</td> <td style="text-align: center;">\$320</td> </tr> <tr> <td style="text-align: center;">125-1000</td> <td style="text-align: center;">\$480</td> </tr> </tbody> </table> </div> <div style="width: 48%;"> <p>BRAKE RELEASE INTERLOCK SWITCH</p> <p>Add as follows:</p> <table border="1" style="width: 100%; border-collapse: collapse;"> <thead> <tr> <th style="text-align: center;">Brake Torque Lb. Ft.</th> <th style="text-align: center;">List Price Addition</th> </tr> </thead> <tbody> <tr> <td style="text-align: center;">1.5-105</td> <td style="text-align: center;">\$708</td> </tr> <tr> <td style="text-align: center;">125-440</td> <td style="text-align: center;">\$842</td> </tr> <tr> <td style="text-align: center;">500-1000</td> <td style="text-align: center;">\$1560</td> </tr> </tbody> </table> </div> </div>	Brake Torque Lb. Ft.	List Price Addition	10-105	\$3976	125-440	\$4446	500-1000	\$4800	Brake Torque Lb. Ft.	List Price Addition	1.5-6	\$458	10-105	\$640	125-1000	\$1132	Brake Torque Lb. Ft.	List Price Addition	1.5-105	\$320	125-1000	\$480	Brake Torque Lb. Ft.	List Price Addition	1.5-105	\$708	125-440	\$842	500-1000	\$1560
Brake Torque Lb. Ft.	List Price Addition																														
10-105	\$3976																														
125-440	\$4446																														
500-1000	\$4800																														
Brake Torque Lb. Ft.	List Price Addition																														
1.5-6	\$458																														
10-105	\$640																														
125-1000	\$1132																														
Brake Torque Lb. Ft.	List Price Addition																														
1.5-105	\$320																														
125-1000	\$480																														
Brake Torque Lb. Ft.	List Price Addition																														
1.5-105	\$708																														
125-440	\$842																														
500-1000	\$1560																														
8b	<p>EXPLOSIONPROOF BRAKES</p> <p>Refer to Wolong</p>																														

Accessories and Modifications

CD180AT through CD6900

ITEM	DESCRIPTION																																																																
8c	<p>DISC BRAKES – CRANE APPLICATIONS Brakes used on the gantry or trolley function on dockside, portal, or queue cranes require special brakes. Order must specify crane duty and whether trolley or gantry. The features listed below are included on crane duty brakes.</p> <p>Standard Crane Duty Brake Features include:</p> <ul style="list-style-type: none"> • Splined hubs (Zinc plated) and discs • Stainless steel self-adjusting assembly • Full mechanical release with side mounted release lever. Note: Release is not self-resetting • Stainless steel hardware • Space heaters • Brake interlock switch • Dust tight, waterproof enclosure • 56" lead lengths <p>When specifying vertical or horizontal, add as follows:</p> <table border="1" style="width: 100%; border-collapse: collapse; text-align: center;"> <thead> <tr> <th rowspan="4" style="width: 15%;">Lb. Ft. ⁽²²⁾</th> <th colspan="3">Motor Mounted Brake AC Coil Dust Tight/Waterproof</th> </tr> <tr> <th colspan="3">List Price Addition</th> </tr> <tr> <th rowspan="2">Vertical</th> <th colspan="2">Horizontal</th> </tr> <tr> <th>Trolley</th> <th>Gantry</th> </tr> </thead> <tbody> <tr> <td>50</td> <td>\$5751</td> <td>\$5238</td> <td>\$5238</td> </tr> <tr> <td>75</td> <td>\$6561</td> <td>\$6048</td> <td>\$6048</td> </tr> <tr> <td>105</td> <td>\$7545</td> <td>\$6992</td> <td>\$6992</td> </tr> <tr> <td>125</td> <td>\$13538</td> <td>\$12762</td> <td>\$17022*</td> </tr> <tr> <td>175</td> <td>\$13875</td> <td>\$13099</td> <td>\$17359*</td> </tr> <tr> <td>230</td> <td>\$14651</td> <td>\$13774</td> <td>\$18034*</td> </tr> <tr> <td>330</td> <td>\$15460*</td> <td>\$14583*</td> <td>\$18843*</td> </tr> <tr> <td>440</td> <td>\$16945*</td> <td>\$15798*</td> <td>\$20058*</td> </tr> </tbody> </table> <p><small>* Includes fabricated commutator endshield. (22) Lb. Ft. Torque = $\frac{\text{HP} \times 5252}{\text{Motor base speed (RPM)}}$</small></p> <p>Viton Gasket: To replace standard neoprene gasket. Proximity Switch: To replace standard brake interlock switch (microswitch). Breather Drain: To replace standard drain plug. Terminal Board: To replace 56" lead lengths.</p> <table border="1" style="width: 100%; border-collapse: collapse; text-align: center;"> <thead> <tr> <th colspan="5">List Price Addition</th> </tr> <tr> <th>Brake Rating</th> <th>Viton Gasket</th> <th>Proximity Switch</th> <th>Breather Drain</th> <th>Terminal Board</th> </tr> </thead> <tbody> <tr> <td>105 Ft. Lb. and Smaller</td> <td>\$138</td> <td>\$1855</td> <td>\$552</td> <td>\$180</td> </tr> <tr> <td>125 Ft. Lb. and Larger</td> <td>\$220</td> <td>\$3767</td> <td>\$614</td> <td>\$180</td> </tr> </tbody> </table>	Lb. Ft. ⁽²²⁾	Motor Mounted Brake AC Coil Dust Tight/Waterproof			List Price Addition			Vertical	Horizontal		Trolley	Gantry	50	\$5751	\$5238	\$5238	75	\$6561	\$6048	\$6048	105	\$7545	\$6992	\$6992	125	\$13538	\$12762	\$17022*	175	\$13875	\$13099	\$17359*	230	\$14651	\$13774	\$18034*	330	\$15460*	\$14583*	\$18843*	440	\$16945*	\$15798*	\$20058*	List Price Addition					Brake Rating	Viton Gasket	Proximity Switch	Breather Drain	Terminal Board	105 Ft. Lb. and Smaller	\$138	\$1855	\$552	\$180	125 Ft. Lb. and Larger	\$220	\$3767	\$614	\$180
Lb. Ft. ⁽²²⁾	Motor Mounted Brake AC Coil Dust Tight/Waterproof																																																																
	List Price Addition																																																																
	Vertical		Horizontal																																																														
		Trolley	Gantry																																																														
50	\$5751	\$5238	\$5238																																																														
75	\$6561	\$6048	\$6048																																																														
105	\$7545	\$6992	\$6992																																																														
125	\$13538	\$12762	\$17022*																																																														
175	\$13875	\$13099	\$17359*																																																														
230	\$14651	\$13774	\$18034*																																																														
330	\$15460*	\$14583*	\$18843*																																																														
440	\$16945*	\$15798*	\$20058*																																																														
List Price Addition																																																																	
Brake Rating	Viton Gasket	Proximity Switch	Breather Drain	Terminal Board																																																													
105 Ft. Lb. and Smaller	\$138	\$1855	\$552	\$180																																																													
125 Ft. Lb. and Larger	\$220	\$3767	\$614	\$180																																																													

Accessories and Modifications

CD180AT through CD6900

Accessories and Modifications

ITEM	DESCRIPTION																																							
9	<p>CANADIAN STANDARDS ASSOCIATION (CSA) APPROVAL For CSA approval, no price addition except for TEAAC, TEWAC enclosures in a CD5010AY frame, add \$500 NET. For explosionproof motor adder, refer to page 2.24.</p> <p>Note: CSA approval must be specified at time of order.</p>																																							
10	<p>CE MARK, EUROPEAN STANDARDS This modification provides for a motor that meets the standards requirements of the Low Voltage Directive 73/23/EEC and relevant sections of the Machinery Directive 98/37/EC and EMC Directive 89/336/EEC. These motors will be CE marked on the nameplate in accordance with the marking requirements of the Low Voltage Directive.</p> <table border="1" data-bbox="188 730 1500 957"> <thead> <tr> <th rowspan="2">Motor Enclosure</th> <th colspan="5">FRAME SIZE</th> </tr> <tr> <th>CD210AT-CD320AT</th> <th>CD360AT</th> <th>CD400AT-CD500AT</th> <th>CD6000-CD6200</th> <th>CD6700-CD6900</th> </tr> </thead> <tbody> <tr> <td></td> <td colspan="5" style="text-align: center;">List Price Addition</td> </tr> <tr> <td>SPFG*, SPFG-SV*, TENV, TEFC</td> <td>\$2000</td> <td>\$2100</td> <td>\$2900</td> <td>\$3200</td> <td>\$3700</td> </tr> <tr> <td>SPFG-BV*, TEWAC, TEAO</td> <td>\$3154 •</td> <td>\$3254 •</td> <td>\$4054 •</td> <td>\$5310</td> <td>\$5310</td> </tr> <tr> <td>TEAAC</td> <td></td> <td>\$4408</td> <td>\$5208</td> <td>\$6400</td> <td>\$9530</td> </tr> </tbody> </table> <p>* The price addition for CE mark does not include the splashproof enclosure modification. See splashproof enclosure price additions on page 3.14. • TEWAC not available on CD210AT-CD400AT frame motors.</p> <p>CE mark pricing includes:</p> <ul style="list-style-type: none"> • Terminal board in conduit box • Ground lug in conduit box • Ground lug and tapped holes in foot (only on motors rated 100kw and higher) • Special nameplates • 50 Hz marked blower motor(s) on blower ventilated, TEAO, TEAAC, TEWAC • Declaration of Conformity, Declaration of Incorporation • Instruction book in either Spanish, French, German, Italian or English <p>Note: All CE marked motors must be reviewed with Engineering to make sure CE temperature rise limits are met. If the standard motor does not meet CE mark temperature rise limits (on armature and comm field), the price addition for Class B temperature rise must be used in addition to the above CE mark price additions.</p> <p>Note: CD180AT and Explosionproof ratings are not available for CE marking.</p> <p>Note: DPGF, DPGF-BV, and DPGF-SV motor enclosures are not available for CE marking.</p> <p>Note: CE approved accessories must be used.</p>					Motor Enclosure	FRAME SIZE					CD210AT-CD320AT	CD360AT	CD400AT-CD500AT	CD6000-CD6200	CD6700-CD6900		List Price Addition					SPFG*, SPFG-SV*, TENV, TEFC	\$2000	\$2100	\$2900	\$3200	\$3700	SPFG-BV*, TEWAC, TEAO	\$3154 •	\$3254 •	\$4054 •	\$5310	\$5310	TEAAC		\$4408	\$5208	\$6400	\$9530
Motor Enclosure	FRAME SIZE																																							
	CD210AT-CD320AT	CD360AT	CD400AT-CD500AT	CD6000-CD6200	CD6700-CD6900																																			
	List Price Addition																																							
SPFG*, SPFG-SV*, TENV, TEFC	\$2000	\$2100	\$2900	\$3200	\$3700																																			
SPFG-BV*, TEWAC, TEAO	\$3154 •	\$3254 •	\$4054 •	\$5310	\$5310																																			
TEAAC		\$4408	\$5208	\$6400	\$9530																																			

Accessories and Modifications

CD180AT through CD6900

ITEM	DESCRIPTION
11	<p>CONDUIT BOXES, SPECIAL Note: F1 - The conduit box is located on the right-hand side (as viewed from the commutator end). F2 - The conduit box is located on the left-hand side (as viewed from the commutator end). On CD180AT frames, other than explosionproof, the conduit box is built into the endshield and is available in the F1 location only. On all other frames, a standard conduit box is used. CD6000-CD6900 frames, as standard, provide a conduit box with fixed terminations for armature, field, and internal accessory leads. Special conduit boxes are as follows:</p>
11a	<p>AUXILIARY CONDUIT BOX OR CONDULET Allows accessory leads to be brought into a separate conduit box or conduit. When this feature is specified, the auxiliary conduit box or conduit will always be supplied on the side of the motor which is opposite to the main conduit box location. Note: The purchaser must specify which accessory leads are to be brought to the auxiliary conduit box or conduit. Accessories external to the motor are not wired to the auxiliary box or conduit.</p>
11b	<p>CAST IRON CONDUIT BOX Not available on all frames.</p>
11c	<p>EXPLOSIONPROOF CONDUIT BOX AND SEALED LEADS ON SEPARATELY VENTILATED MOTORS (Not available on frames CD180AT) For use only on enclosed separately ventilated motors with air ducted-in and air ducted-out ventilation. Section 501-8 and 502-8 of the National Electrical Code permits the use of enclosed separately ventilated motors with air ducted-in and air ducted-out ventilation in certain locations, when installation and operation conform to certain requirements. It is the responsibility of the user to obtain approval from the local authorities for such installation. For additional information, see page 2.25.</p>
<p>The addition of this modification does not provide a U.L. listed explosionproof motor.</p>	
<p>A thermostat is required when an explosion proof conduit box is supplied with a separately ventilated motor. Accessories such as tachometers or brakes mounted on the motor must be of the explosion proof type. See page 3.25, Item 29b for BC tachs. Refer to Wolong for explosion proof brakes.</p>	
11d	<p>OVERSIZE CONDUIT BOX Supplied at no additional price on frames CD218AT-CD5010AY upon request. Price addition is required for oversize conduit box on frames CD6000-CD6900.</p>
11e	<p>TOP MOUNTED CONDUIT BOX On frames CD218AT-CD5010AY, top mounted conduit boxes are not available with a TEAAC or TEWAC enclosure. Refer to GE for top mounted conduit boxes on blower ventilated CD218AT-CD5010AY frames. Top mounted explosion proof box not available on CD210AT-CD320AT.</p>

Accessories and Modifications

Accessories and Modifications

CD180AT through CD6900

Accessories and Modifications

ITEM	DESCRIPTION												
11f	WATERPROOF CONDUIT BOX												
	For use on splashproof or better enclosure. For use where motors are required to exclude water applied from a hose and for outdoor application. Included in the price addition for waterproof motor enclosure. Not available on frames CD6000-CD6900. The standard conduit box used on frames CD6000-CD6900 is gasketed and "water-resistant."												
	SPECIAL CONDUIT BOX		MOTOR FRAME SIZE										
			CD210AT- CD320AT	CD360AT- CD400AT	CD504AT- CD508AT	CD5010AY	CD6000- CD6200	CD6700- CD6900					
	List Price Addition												
	a. Auxiliary conduit box or conduit: Conduit box for accessory leads		\$754	\$1508	\$1508	\$1508	\$3954	\$4780					
	Condulet for accessory leads		\$376	\$754	\$754	\$754	Not Available						
	b. Cast iron conduit box		\$225	Refer to GE		Refer to GE		Refer to GE					
	c. Explosionproof conduit box with motor leads sealed at the frame exit Standard conduit box with motor leads sealed a the frame exit		\$2116	\$6658	\$8256	\$12044	\$51784	\$51784					
			\$1875	\$1238	\$1238	\$1806	\$7766	\$7766					
d. Oversize conduit box		0	0	0	0	\$1730	\$1730						
e. Top mounted conduit box		\$838*	\$2106*	\$2106*	\$2106*	\$4606*	\$9414*						
f. Waterproof conduit box		\$450	\$900	\$900	\$900	Not Available							
* Not available in all enclosures. Refer to Item 11e.													
12	COVER, TRANSPARENT												
	A single transparent cover is used in place of the metal cover on a brush opening at the commutator end. On frames CD218AT-CD5010AY, the standard transparent cover is Lucite® or equivalent. On frames CD6000-CD6900, the standard transparent cover is Lexan or equivalent. Lexan is available on frames CD218AT-CD5010AY. See below for pricing per motor.												
	DESCRIPTION		MOTOR LIST PRICE										
Up to \$2500			\$2501 to 3592	\$3593 to \$5578	\$5579 to \$9748	\$9749 to \$13218	\$13219 to \$23922	\$23923 to \$42136	\$42137 to \$61750	\$61751 to \$98628	\$98629 to \$157704	\$157704 to \$252288	\$252289 to \$403650
List Price Addition													
a. Lucite or equivalent		(Not available on all CD180AT frames or CD210AT TEFC frames.)		\$270	\$270	\$406	\$406	\$406	\$406	\$540	Not Available		
b. Lexan or equivalent				\$540	\$540	\$812	\$812	\$812	\$812	\$1080	\$1080	\$1080	\$1080
Lucite® is a registered trademark of DuPont Company.													

Accessories and Modifications

CD180AT through CD6900

ITEM	DESCRIPTION																																											
13	<p>CRANE MOTORS We build DC motors designed specifically for dockside and floating crane applications. Motors in these applications are main hoists, boom hoists, trolleys, and gantries. Note: CD180AT frames or AN-DC tachs are not used in crane motor applications. Similarly, TEFC enclosures are not suitable for crane applications (use TEAO), TEAAC and TEWAC waterproof enclosures are not available.</p>																																											
	<table border="1"> <thead> <tr> <th data-bbox="186 562 532 659" rowspan="2">CRANE MOTORS</th> <th colspan="5" data-bbox="532 562 1503 604">MOTOR FRAME SIZE</th> </tr> <tr> <th data-bbox="532 604 695 659">CD210AT- CD250AT</th> <th data-bbox="695 604 857 659">CD280AT</th> <th data-bbox="857 604 1019 659">CD320AT</th> <th data-bbox="1019 604 1182 659">CD360AT- CD400AT</th> <th data-bbox="1182 604 1344 659">CD504AT- CD5010AY</th> <th data-bbox="1344 604 1503 659">CD6000- CD6200</th> </tr> <tr> <th colspan="6" data-bbox="186 659 1503 695">List Price Addition</th> </tr> </thead> <tbody> <tr> <td data-bbox="186 695 532 724">a. Indoor main hoist/boom hoist</td> <td colspan="3" data-bbox="532 695 1019 724">Not Applicable</td> <td data-bbox="1019 695 1182 724">\$2592</td> <td data-bbox="1182 695 1344 724">\$2592</td> <td data-bbox="1344 695 1503 724">\$6382</td> </tr> <tr> <td data-bbox="186 724 532 753">b. Outdoor trolley/gantry</td> <td data-bbox="532 724 695 753">\$3806</td> <td data-bbox="695 724 857 753">\$4492</td> <td data-bbox="857 724 1019 753">\$4492</td> <td data-bbox="1019 724 1182 753">\$5208</td> <td data-bbox="1182 724 1344 753">\$5792</td> <td data-bbox="1344 724 1503 753" rowspan="2">Not Available</td> </tr> <tr> <td data-bbox="186 753 532 783">c. D-flange</td> <td data-bbox="532 753 695 783">\$964</td> <td data-bbox="695 753 857 783">\$1054</td> <td data-bbox="857 753 1019 783">\$3466**</td> <td data-bbox="1019 753 1182 783">\$5322**</td> <td data-bbox="1182 753 1344 783">\$6824**</td> </tr> </tbody> </table>						CRANE MOTORS	MOTOR FRAME SIZE					CD210AT- CD250AT	CD280AT	CD320AT	CD360AT- CD400AT	CD504AT- CD5010AY	CD6000- CD6200	List Price Addition						a. Indoor main hoist/boom hoist	Not Applicable			\$2592	\$2592	\$6382	b. Outdoor trolley/gantry	\$3806	\$4492	\$4492	\$5208	\$5792	Not Available	c. D-flange	\$964	\$1054	\$3466**	\$5322**	\$6824**
CRANE MOTORS	MOTOR FRAME SIZE																																											
	CD210AT- CD250AT	CD280AT	CD320AT	CD360AT- CD400AT	CD504AT- CD5010AY	CD6000- CD6200																																						
List Price Addition																																												
a. Indoor main hoist/boom hoist	Not Applicable			\$2592	\$2592	\$6382																																						
b. Outdoor trolley/gantry	\$3806	\$4492	\$4492	\$5208	\$5792	Not Available																																						
c. D-flange	\$964	\$1054	\$3466**	\$5322**	\$6824**																																							
	<p>** Price includes special bracket.</p> <table border="0"> <tr> <td data-bbox="186 856 792 1104" style="background-color: #f0f0f0; padding: 5px;"> <p>Indoor main hoist/boom hoist features include:</p> <ul style="list-style-type: none"> Crane duty paint Space heater Normally closed thermostat Special conduit box adapter </td> <td data-bbox="899 856 1503 1104" style="background-color: #f0f0f0; padding: 5px;"> <p>Outdoor trolley/gantry features include:</p> <ul style="list-style-type: none"> Waterproof features Crane duty paint Space heater Normally closed thermostat Special conduit box adapter </td> </tr> </table> <p>Note: For crane duty brakes, see page 3.7, Item 8c. For voltages other than those listed above, refer to page 3.32 Item 34.</p>						<p>Indoor main hoist/boom hoist features include:</p> <ul style="list-style-type: none"> Crane duty paint Space heater Normally closed thermostat Special conduit box adapter 	<p>Outdoor trolley/gantry features include:</p> <ul style="list-style-type: none"> Waterproof features Crane duty paint Space heater Normally closed thermostat Special conduit box adapter 																																				
<p>Indoor main hoist/boom hoist features include:</p> <ul style="list-style-type: none"> Crane duty paint Space heater Normally closed thermostat Special conduit box adapter 	<p>Outdoor trolley/gantry features include:</p> <ul style="list-style-type: none"> Waterproof features Crane duty paint Space heater Normally closed thermostat Special conduit box adapter 																																											

Accessories and Modifications

Accessories and Modifications

CD180AT through CD6900

Accessories and Modifications

ITEM	DESCRIPTION
14	<p>CUSTOMER-SUPPLIED MATERIAL No testing is performed and no warranty is provided for customer-supplied material. All customer-supplied material must be sent to the following.</p> <p>Monterrey L&M/GE Industrial Motors 605 NAFTA Blvd Milo Distribution Center Laredo, Texas 78045 Attn: Customer Service</p>
14a	<p>BRAKE WHEEL Customer-supplied DS brake wheels must be completely machined and dynamically balanced prior to receipt at the factory. The factory cannot rebalance the motor after assembly of customer-supplied brake wheel. Add \$3192 list per motor. This price addition is for mounting a brake wheel on the commutator end shaft extension only. Contact Wolong for mounting any other brake components or assemblies to the motor. Note: Refer to Wolong for application of brakes rated above 100% of rated motor torque. Mounting/installation instructions, outline dimensions, and parts list must be received at the time of order. Brake wheel must be received at the factory <u>a minimum of 3 weeks</u> prior to promised ship date. Brake wheel mounting on frames CDL182AT-CD5010AY requires a commutator end shaft extension adder. Refer to page 3.19, Item 24. No adder required for Comm End Shaft Extension on CD6000-CD6900 frames.</p>
14b	<p>COUPLINGS (Customer to supply installation instructions for coupling to Wolong) For mounting a coupling (which must be completely machined and balanced prior to receipt at the factory), WITH finish bore and keyseat, add \$3192 list per motor. The factory cannot rebalance the motor after assembly of customer-supplied coupling. Finish bored and key seated coupling and outline drawings must be received at the factory <u>a minimum of 3 weeks</u> prior to promised ship date. For mounting a coupling (which must be balanced prior to receipt at the factory), WITHOUT finish bore and keyseat, add \$6932 list per motor. Unfinished coupling and outline drawings must be received at the factory <u>a minimum of 4 weeks</u> prior to promised ship date.</p>
14c	<p>TACHOMETER GENERATOR EQUIPMENT Customer-supplied tachometers will not be tested. Drawings, installation instructions and parts list of customer-supplied tachometers must be received at the factory <u>a minimum of 3 weeks</u> prior to promised ship date. For pricing, refer to page 3.29, Item 29c.</p>
14d	<p>PAINT Due to hazardous waste disposal regulations and VOC emissions requirements, Wolong will not accept orders <u>using customer-supplied</u> paint. For special paint requirements needed to meet application and commercial needs, contact Wolong.</p>
15	<p>DRAINS Drain holes are normally selected to provide drainage of moisture that might collect at the lowest point of the motor. Not available on CD180AT Frames. When drain holes are required, placement for horizontal and vertical mount are as follows: Horizontal Mount (1) at each end, vertical CD210AT-CD320AT: (3) at lowest point, CD360AT and above: (1) at lowest point.</p> <p>15a TAPPED HOLE, add \$430 list per motor. No adder required for Waterproof enclosures.</p> <p>15b TAPPED HOLE WITH SOLID PLUG, add \$430 list per motor. No adder required for Waterproof enclosures.</p> <p>15c AUTOMATIC DRAIN BREATHER, add \$510 list per motor. Available on totally enclosed CD210AT-CD5010AY frames only. Not available on CD6000 frames.</p>

Accessories and Modifications

CD180AT through CD6900

ITEM	DESCRIPTION
16	ENCLOSURES
16a	<p>BLOWER VENTILATED, FULLY GUARDED (DPFG-BV) For use on fully guarded motors where the application requires extended periods of low-speed operation by armature voltage control at full load torque. The amount of ventilating air is independent of motor speed, allowing constant torque operation with safe operating temperatures down to five percent rated speed with most power supplies. See application section page 5.3 for motor heating limitations.</p> <p>The standard blower motor is 230/460 Volt AC, 60 hertz and is suitable for (but not nameplated for) 220-240/440-480 Volt AC, 60 hertz. Refer to Wolong for 50 hertz blowers and special blower motor voltages.</p> <p>Filters are optional for applications requiring protection against particles in the air. For fine particles such as cast iron dust, a blower and filter is not recommended. For these conditions, totally enclosed construction or separate ventilation should be considered. Blower filters on frames CD5010AY and below are washable. Filters for frames CD6000-CD6900 are disposable. For use of splash-proof fully guarded on blower ventilated motors, see page 3.14, Item 16d.</p>
16b	<p>SEPARATELY VENTILATED, FULLY GUARDED OR TOTALLY ENCLOSED SEPARATELY VENTILATED (DPFG-SV) OR (TESV) For applications where a contaminated atmosphere is encountered, ventilating air is piped into the motor or generator from an external source to the commutator end on frames CDL182AT-CD5010AY and to the drive end on CD6000-CD6900 frames. Openings have drilled and tapped holes for convenient duct connection. Price does not include blower, pipe or duct. See page 5.13 for separate ventilating air requirements.</p> <p>Separately ventilated motors with recommended air supply are suitable for constant torque operation with allowable operating temperatures down to five percent base speed with most power supplies. See application section page 5.3 for motor heating limitations.</p> <p>On separately ventilated, fully guarded motors, air is expelled into the surrounding environment through air exhaust openings which are fully guarded.</p> <p>For use of splashproof on separately ventilated, fully guarded motors, see page 3.14, Item 16c.</p> <p>On totally enclosed separately ventilated motors, the ventilating air is ducted in and out of the motor and solid covers are placed on all other air openings. The motor is then inherently splashproof, and the addition of the splashproof modification to a totally enclosed separately ventilated motor is not necessary.</p> <p>Note: CD180AT motors must have an 8 1/2" C-Face. Totally enclosed separately ventilated CD180AT frames in hazardous locations are not available.</p>

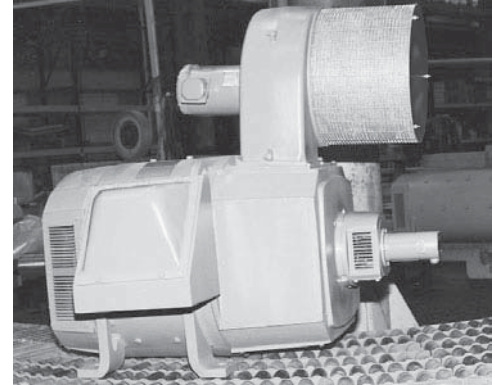

Dripproof Fully Guarded Blower Ventilator (DPFG-BV) (Shown above with filter)

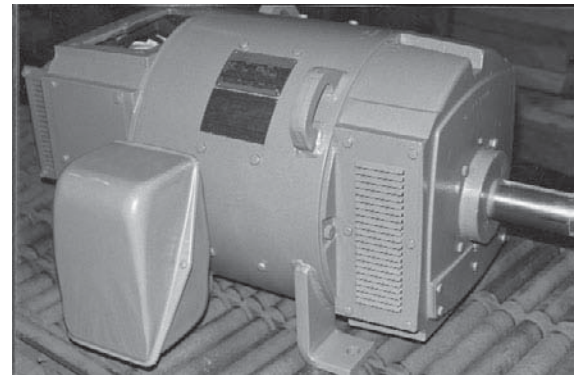

Dripproof Fully Guarded, Separately-Ventilated (DPFG-SV) (Frame CD366AT shown above with air inlet on top of motor commutator end. Other air inlet locations available.)

Accessories and Modifications

Accessories and Modifications

CD180AT through CD6900

Accessories and Modifications

ITEM	DESCRIPTION
16c	<p>SPLASHPROOF FULLY GUARDED (SPFG) (FOR SEPARATELY VENTILATED OR SELF-VENTILATED FULLY GUARDED MOTORS) Provides for bolted-on splash covers to meet NEMA Standard MG-1-2009, Part 1.25.2. The covers are constructed to prevent liquids and solid particles from entering in a straight line at any angle not greater than 60° from the vertical. This does not apply to motors operated in a vertical position. For these applications, refer to Wolong. For CD180AT frames, splash-proof fully guarded, separately ventilated is only available when horizontally mounted.</p>
16d	<p>SPLASHPROOF FULLY GUARDED (FOR BLOWER VENTILATED, FULLY GUARDED MOTORS) For splash-proof fully guarded, blower ventilated, list price additions for Modifications a. and d. must both be added. Provides for bolted-on splash covers to meet NEMA Standard MG-1-2009, Part 1.25.2. The covers are constructed to prevent liquids and solid particles from entering in a straight line at any angle not greater than 60° from the vertical. In addition, on CD6000-CD6900 frames with a splash-proof fully guarded, blower ventilated enclosures, splash-proof hoods are required to cover the blower air inlets. See page 4.37 for outline dimensions of frames CD6000-CD6900 with a splash-proof, fully guarded blower ventilated enclosure. This does not apply to motors operated in a vertical position. For these applications, refer to Wolong. For CD180AT frames, splash-proof fully guarded, blower ventilated is only available when horizontally mounted.</p>
16e	<p>WATERPROOF (WP) For use where motors are required to exclude water applied from a hose and for outdoor application. (Do not use where ice may form on fan of TEFC motors or generators.) Waterproof features are not available in TEAAC or TEWAC. Standard waterproof features for frames CDL182AT-CD5010AY (TEFC, TENV, and TEAO) include:</p> <ul style="list-style-type: none"> • Spot faced surfaces on frame under the pole bolts • Washers under pole bolts • Drain holes at low point of machine • Polyurethane paint • Special neoprene-gasketed, heavy handhold covers with machined surfaces on cover and bearing bracket • Waterproof conduit box with tapped conduit entrance hole and machined mating surfaces (Not on CD180AT. On CD180AT frames the conduit box is built into the endshield.) • Sealed frame fits and special treatment of all mating surfaces • Lip type rubbing seals on both outboard bearings (where applicable) • Corrosion-resistant hardware <p>Space heaters are recommended for all waterproof motors.</p>

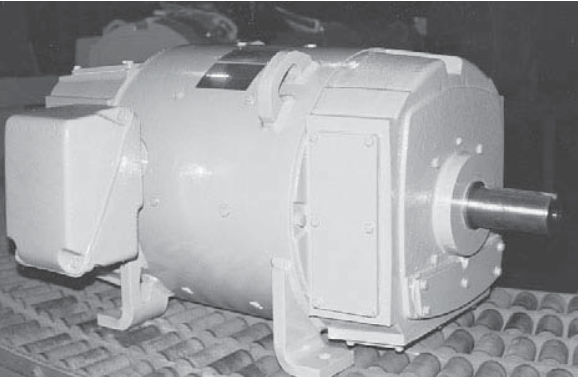

Totally Enclosed Nonventilated Waterproof (TENV-WP)
 (Frame CD407ATY shown above)

Accessories and Modifications

CD180AT through CD6900

ITEM	DESCRIPTION													
16f	DUSTPROOF (DP) Applies to frames CDL182AT-CD5010AY with TEFC and TENV enclosures only. For applications requiring protection against fine abrasive dust such as taconite. Price addition includes: <ul style="list-style-type: none"> • Metal labyrinth seal on drive end • Gasketed handhole covers • A sealed dust cap on the commutator end of TENV motors • A labyrinth seal on the commutator end of TEFC motors. For cement mill applications or for TEAC or TEWAC motors, refer to Wolong. 													
	16g TROPICAL PROTECTION Suitable for operation in tropical climates, where fungus and high humidity are present, without price addition. Space heaters are recommended for motors to be used in environments where high humidity is present. (See page 3.21, Item 26 for space heaters.)													
	ENCLOSURE	MOTOR LIST PRICE												
		Up to \$2500	\$2501 to \$3592	\$3593 to \$5578	\$5579 to \$9748	\$9749 to \$13218	\$13219 to \$23922	\$23923 to \$42136	\$42137 to \$61750	\$61751 to \$98628	\$98629 to \$157704	\$157704 to \$252288	\$252289 to \$403650	\$403651 and up
		List Price Addition												
	a. Blower Ventilated Motor-mounted blower with filter: 230/460 V or 575V, 3Ph, 60 Hz	\$1472	\$1472	\$1472	\$2274	\$2576	\$2866	\$3158	\$3706	\$4778	\$13578	\$16848	\$28904	\$28904
	Motor-mounted blower without filter: 230/460V or 575V, 3Ph, 60 Hz	\$1032	\$1032	\$1032	\$1814	\$1814	\$2318	\$2318	\$3014	\$4306	\$7090	\$8214	\$12516	\$12516
	For 190/380V, 50 Hz Blower Motors, add to blower assembly (a) above	\$208	\$208	\$208	\$364	\$364	\$464	\$464	\$604	\$862	\$1418	\$1644	\$2504	\$2504
	b. Separately ventilated, fully guarded or enclosed separately ventilated	For CDL182AT-CD5010AY and CD6000-CD6900 frames, NO PRICE ADDITION												
	c. Splashproof, fully guarded (for use with self of separately ventilated, fully guarded machines)	\$204	\$204	\$420	\$636	\$810	\$810	\$810	\$810	\$1216	\$1216	\$1216	\$1216	\$1620
	d. Splashproof, fully guarded (for use with blower ventilated fully guarded machines) Modification Item a. must also be added for splashproof, fully guarded, blower ventilated	\$204	\$312	\$420	\$636	\$810	\$810	\$810	\$810	\$1216	\$4086	\$4086	\$6762	\$7368
	e. Waterproof	\$1502	\$1502	\$1658	\$2050	\$2520	\$3100	\$3810	\$4710	\$5780	Not Available			
	f. Dustproof (taconite dusts)	\$304	\$340	\$486	\$756	\$988	\$620	\$1570	\$1700	\$1970	Not Available			
	Note: Items e. and f. apply to totally enclosed motors. Items b. and c. apply to splashproof fully guarded, separately ventilated motors. Items a. and d. apply to splashproof fully guarded, blower ventilated motors.													

Accessories and Modifications

Accessories and Modifications

CD180AT through CD6900

ITEM	DESCRIPTION
------	-------------

17 ENDSHIELDS
Standard NEMA Type C-Face and Type D-Flange dimensions are shown on the dimensions pages. Refer to **Wolong** for CD6000-CD6900 frames. Where oil will be above the bottom of the horizontal shaft, including splashing or spraying, a special shaft seal is required. (Refer to page 3.18, Item 22 for shaft seal.)

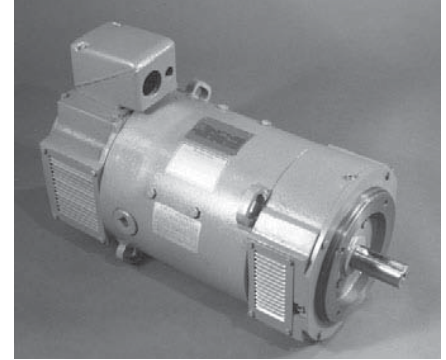

NEMA Type C-Face Endshield

17a Type C-Face Endshields are available on frames CD320AT and below. NEMA does not specify C-Face dimensions for CD365AT-CD5010AY frames. The desired C-Face dimensions must be approved by **Wolong** and specified with the order.

17b Type D-Flange Endshields are available on frames CD5010AY and below. Available on frame 5010AY if supported by feet.

17c P-Base Adapters — NEMA does not specify P-Base dimensions for DC motors. The desired P-Base dimensions must be approved by **Wolong** and specified with the order. The factory will use an adapter on a D-Flange (price included in P-Base adder) to achieve desired dimensions. Apply adder from page 3.31, Item 33 for vertical mounting. If special drive end shaft dimensions are required, see page 3.19, Item 24 for adder.

SPECIAL ENDSHIELDS	MOTOR FRAME SIZE								
	CD180AT	CD210AT	CD250AT	CD280AT	CD320AT	CD360AT	CD400AT	CD500AT	CD5010AY
	List Price Addition								
a. Type C-Face	\$172†	\$502	\$652	\$846	\$1100	‡	‡	‡	‡
b. Type D-Flange	\$216	\$964	\$1060	\$1706	\$1282	\$5356	\$6644	\$7308‡‡	\$7308‡‡
c. P-Base Adapter	\$648	\$1928	\$2312	\$2774	\$3328	\$6652	\$8636	\$9500	\$9500

†For CD180AT frames, please specify 4.5" or 8.5" C-Face.

‡Contact **Wolong**

‡‡On CD5010AY frames, motor must also be supported by feet.

The following chart details the standard endshield material used on Kinamatic motors. Non-standard Kinamatic motors manufactured for special applications may not use standard endshield material. Refer to **Wolong** for non-standard motors.

ENDSHIELD	MOTOR FRAME SIZE								
	CD180AT	CD210AT	CD250AT	CD280AT	CD320AT	CD360AT	CD400AT	CD500AT	CD5010AY
	STANDARD ENDSHIELD MATERIAL								
a. Standard Drive End	Cast Iron	Cast Iron (16)	Cast Iron (16)	Cast Iron (16)	Cast Iron (16)	Cast Iron (16)	Cast Iron (16)	Cast Iron (16)	Ductile Iron
b. C-Face Drive End	Cast Iron	Cast Iron (16)	Cast Iron (16)	Cast Iron (16)	Cast Iron (16)	Fabricated Steel	Not Available	Not Available	Not Available
c. D-Flange Drive End	Cast Iron	Cast Iron (16)	Cast Iron (16)	Cast Iron (16)	Cast Iron (16)	Fabricated Steel	Fabricated Steel	Fabricated Steel	Fabricated Steel
d. P-Base Drive End	Cast Iron	Cast Iron (16)	Cast Iron (16)	Cast Iron (16)	Cast Iron (16)	Fabricated Steel	Fabricated Steel	Fabricated Steel	Fabricated Steel
e. Commutator End	Cast Iron	Cast Iron (16)	Cast Iron (16)	Cast Iron (16)	Cast Iron (16)	Cast Iron (16)	Cast Iron (16)	Cast Iron (16)	Cast Iron (16)

Price addition for fabricated steel (per endshield) is as follows:

Motor Frame Size	List Price Addition
CD210AT-CD320AT	\$2412
CD360AT	\$3600
CD400AT	\$4268
CD500AT	\$4826
CD5010AY	Not Available

(16) Fabricated steel is available.

Accessories and Modifications

CD180AT through CD6900

ITEM	DESCRIPTION																																						
18	<p>EXPORT BOXING The price for export boxing is a NET PRICE adder applied to the total price of the motor after adjusting for all modifications. Export boxing must be specified at the time of order.</p> <table border="1" data-bbox="185 495 1502 638"> <thead> <tr> <th data-bbox="185 495 402 600" rowspan="2">Export Boxing</th> <th colspan="9" data-bbox="402 495 1502 533">FRAME SIZE</th> </tr> <tr> <th data-bbox="402 533 524 600">CD182- CD2110</th> <th data-bbox="524 533 646 600">CD250- CD320</th> <th data-bbox="646 533 768 600">CD365- CD409</th> <th data-bbox="768 533 889 600">CD504- CD5010</th> <th data-bbox="889 533 1011 600">CD6000- CD6100</th> <th data-bbox="1011 533 1133 600">CD6200</th> <th data-bbox="1133 533 1255 600">CD6700</th> <th data-bbox="1255 533 1377 600">CD6800</th> <th data-bbox="1377 533 1502 600">CD6900</th> </tr> </thead> <tbody> <tr> <td data-bbox="185 600 402 638">Net Price</td> <td data-bbox="402 600 524 638">\$400</td> <td data-bbox="524 600 646 638">\$600</td> <td data-bbox="646 600 768 638">\$800</td> <td data-bbox="768 600 889 638">\$1000</td> <td data-bbox="889 600 1011 638">\$1400</td> <td data-bbox="1011 600 1133 638">\$2000</td> <td data-bbox="1133 600 1255 638">\$2500</td> <td data-bbox="1255 600 1377 638">\$3000</td> <td data-bbox="1377 600 1502 638">\$3700</td> </tr> </tbody> </table>										Export Boxing	FRAME SIZE									CD182- CD2110	CD250- CD320	CD365- CD409	CD504- CD5010	CD6000- CD6100	CD6200	CD6700	CD6800	CD6900	Net Price	\$400	\$600	\$800	\$1000	\$1400	\$2000	\$2500	\$3000	\$3700
Export Boxing	FRAME SIZE																																						
	CD182- CD2110	CD250- CD320	CD365- CD409	CD504- CD5010	CD6000- CD6100	CD6200	CD6700	CD6800	CD6900																														
Net Price	\$400	\$600	\$800	\$1000	\$1400	\$2000	\$2500	\$3000	\$3700																														
19	GREASE AND FITTINGS																																						
19a	<p>GREASE The following greases are available: Standard (Alvania® #2) or equivalent. Suitable for 15°F (-10°C) to 212°F (100°C) ambient temperature. No price addition. Low Temperature (Shell Aeroshell® #7) or equivalent. Suitable for -60°F (-51°C) to 200°F (93°C) ambient temperature. Add \$172 list per motor. High Temperature (Mobil Polyrex EM®) or equivalent. Suitable for -20°F (-28°C) to 350°F (176°C) ambient temperature. Add \$172 list per motor.</p>																																						
19b	FITTINGS																																						
	<p>Grease fittings — Not necessary on frames CDL182AT-CD2110AT because prelubricated and shielded bearings are standard. On CD258AT-CD5010AY and CD6000-CD6900 frames, zerk grease fittings are standard. When grease fittings are required, open ball bearings and bearing caps are included. (Not available on CD180 frames.) No price addition. For re-greaseable bearings with standard alemite grease fittings on CD218AT-CD2110AT, add \$516 list per motor. For special grease fittings, button head, pin head or other than standard, add \$172 list per motor. Pressure Relief Valve add \$172 list per motor.</p>																																						
20	<p>CURRENT OVERLOAD — MAXIMUM LOAD AT BASE SPEED In accordance with NEMA standards, continuous rated industrial DC motors rated 3/4 HP/RPM and less shall be capable of occasionally repeated loads of 150% of the base speed full load current at all speeds within the standard speed ranges listed on pages 2.4 – 2.29. Although NEMA does not specify frequently repeated load capability, DC motors in these ratings are capable of 140%. For motors larger than 3/4 HP/RPM, the following load capability applies:</p> <table border="1" data-bbox="185 1535 1502 1661"> <thead> <tr> <th data-bbox="185 1535 451 1570">Percent Base Speed</th> <th data-bbox="451 1535 824 1570">Occasionally Repeated Loads</th> <th data-bbox="824 1535 1502 1570">Frequently Repeated Loads</th> </tr> </thead> <tbody> <tr> <td data-bbox="185 1570 451 1598">100%</td> <td data-bbox="451 1570 824 1598">150%</td> <td data-bbox="824 1570 1502 1598">140%</td> </tr> <tr> <td data-bbox="185 1598 451 1625">200%</td> <td data-bbox="451 1598 824 1625">150%</td> <td data-bbox="824 1598 1502 1625">130%</td> </tr> <tr> <td data-bbox="185 1625 451 1661">300% or greater</td> <td data-bbox="451 1625 824 1661">140%</td> <td data-bbox="824 1625 1502 1661">125%</td> </tr> </tbody> </table> <p>For occasionally repeated load capability of 200% with a frequency repeated load capability of 175% on motors rated 3/4 HP/RPM and less with standard speed ranges listed on pages 2.4 – 2.29 and on motors rated larger than 3/4 HP/RPM at base speed only, add 10% and refer to Wolong for effect on frame size. Occasionally repeated loads are defined as one-minute duration or less and are not considered as part of the regular duty cycle. Occasionally repeated loads are considered as commutation limits rather than heating limits. Frequently repeated loads are defined as one-minute duration or less repeated such that the RMS current does not exceed rated current over any five-minute period.</p>										Percent Base Speed	Occasionally Repeated Loads	Frequently Repeated Loads	100%	150%	140%	200%	150%	130%	300% or greater	140%	125%																	
Percent Base Speed	Occasionally Repeated Loads	Frequently Repeated Loads																																					
100%	150%	140%																																					
200%	150%	130%																																					
300% or greater	140%	125%																																					

Accessories and Modifications

Accessories and Modifications

CD180AT through CD6900

Accessories and Modifications

ITEM	DESCRIPTION																											
21	<p>PUMP MOTORS</p> <p>DC Motors with armature voltages from 105-130 Volts in most cases are used in pump applications. These are special motors built to pump manufacturer specifications. Because of the low armature voltage these motors have special electrical designs and in many cases frame sizes are larger than standard. If a model number is not available, a request for motors in this voltage range must be accompanied by the following information.</p> <p>Pump motors operated from DC potential busses or batteries will show significant speed variations from nominal when the motor is cold and when the applied voltage varies below nominal.</p> <p>Typically Motor RPM will be lower than nameplate speed (approx. 10-15%) when cold and increase to nameplate RPM as main field reaches operating temperature. To reduce the cold to hot speed variations, the shunt fields should be energized at 50-70% of rated voltage to stabilize. However, for 'emergency' pump motor applications, where field pre-heating may not be feasible, the pump capacity must be sized to the cold start RPM.</p> <p>Also, at lower than nominal voltage the motor will run slower than nameplate RPM, while conversely the motor will run higher than nameplate RPM when voltage is higher than nominal.</p> <p>For Pump Motor quotations, contact Wolong.</p>																											
22	<p>SEALS, DRIVE END SHAFT (horizontal or vertical with shaft up or down)</p> <p>We offer the following shaft seals: Lip type rubbing seals (which provide protection against oil mist or splash), labyrinth seals (which provide protection against fine abrasive dust), and Inpro® seals (which provide protection from liquids, solids, steam, and slurries of all types). Price addition (per seal) is as follows:</p> <p>Note: For availability and pricing of commutator end shaft seals, refer to Wolong.</p> <table border="1" style="width: 100%; margin-top: 10px;"> <thead> <tr> <th rowspan="2">Motor Frame Size</th> <th colspan="3">List Price Addition</th> </tr> <tr> <th>Lip Seal</th> <th>Labyrinth Seal</th> <th>Inpro Seal</th> </tr> </thead> <tbody> <tr> <td>CD180AT-CD210AT</td> <td>\$298</td> <td>\$298</td> <td>Not Available</td> </tr> <tr> <td>CD250AT-CD320AT</td> <td>\$420</td> <td>\$490</td> <td>\$2442</td> </tr> <tr> <td>CD360AT-CD5010AY</td> <td>\$596</td> <td>\$838</td> <td>\$3736</td> </tr> <tr> <td>CD6000-CD6200</td> <td>Not Available</td> <td>\$1138</td> <td>\$6900</td> </tr> <tr> <td>CD6700-CD6900</td> <td>Not Available</td> <td>\$1394</td> <td>\$8912</td> </tr> </tbody> </table> <p style="font-size: small; margin-top: 10px;">Inpro® is a registered trademark of Inpro/Seal Inc., Rock Island, Illinois</p>	Motor Frame Size	List Price Addition			Lip Seal	Labyrinth Seal	Inpro Seal	CD180AT-CD210AT	\$298	\$298	Not Available	CD250AT-CD320AT	\$420	\$490	\$2442	CD360AT-CD5010AY	\$596	\$838	\$3736	CD6000-CD6200	Not Available	\$1138	\$6900	CD6700-CD6900	Not Available	\$1394	\$8912
Motor Frame Size	List Price Addition																											
	Lip Seal	Labyrinth Seal	Inpro Seal																									
CD180AT-CD210AT	\$298	\$298	Not Available																									
CD250AT-CD320AT	\$420	\$490	\$2442																									
CD360AT-CD5010AY	\$596	\$838	\$3736																									
CD6000-CD6200	Not Available	\$1138	\$6900																									
CD6700-CD6900	Not Available	\$1394	\$8912																									

Accessories and Modifications

CD180AT through CD6900

ITEM	DESCRIPTION																								
23	<p>SEVERE MECHANICAL "A" Severe mechanical duty "A" features are used on applications where motors are subject to severe torsional loads (severe transients, rapid reversals), where additional strength of components is required to resist high electromagnetic forces.</p> <p>Severe mechanical duty "A" features include:</p> <ul style="list-style-type: none"> • Solid or pinned, laminated commutating poles • High-strength (grade 8) bolts on both main poles and commutating poles; A black oxide finish on these bolts prevents the possibility of hydrogen embrittlement. • The magnet frame is spotfaced for firm seating of these high strength bolts. • Cables are securely anchored with extra lead tying. • Bolted connections at commutating coils and series coils are insulated to prevent chafing of leads that come in contact with those connections. • A cable clamp is used in the conduit box. • A molded insert is located in the lead exit hole to protect leads from threads and other sharp corners. • For CD360AT, CD400AT, CD504AT-CD508AT, high-strength armature banding and epoxy RHP armature varnish is used. <table border="1" data-bbox="196 989 727 1377"> <thead> <tr> <th data-bbox="196 1031 448 1058">Motor Frame Size</th> <th data-bbox="448 989 727 1058">List Price Addition Duty "A"</th> </tr> </thead> <tbody> <tr> <td data-bbox="196 1062 448 1089">CDL182AT-CD189AT</td> <td data-bbox="448 1062 727 1089">Not Available</td> </tr> <tr> <td data-bbox="196 1094 448 1121">CD218AT-CD2110AT</td> <td data-bbox="448 1094 727 1121">\$892</td> </tr> <tr> <td data-bbox="196 1125 448 1152">CD258AT-CD259AT</td> <td data-bbox="448 1125 727 1152">\$1136</td> </tr> <tr> <td data-bbox="196 1157 448 1184">CD287AT-CD288AT</td> <td data-bbox="448 1157 727 1184">\$1403</td> </tr> <tr> <td data-bbox="196 1188 448 1215">CD327AT-CD328AT*</td> <td data-bbox="448 1188 727 1215">\$1631</td> </tr> <tr> <td data-bbox="196 1220 448 1247">CD329AT</td> <td data-bbox="448 1220 727 1247">Not Available</td> </tr> <tr> <td data-bbox="196 1251 448 1278">CD365AT-CD368AT</td> <td data-bbox="448 1251 727 1278">\$2123</td> </tr> <tr> <td data-bbox="196 1283 448 1310">CD407AT-CD409AT</td> <td data-bbox="448 1283 727 1310">\$2645</td> </tr> <tr> <td data-bbox="196 1314 448 1341">CD504AT-CD508AT</td> <td data-bbox="448 1314 727 1341">\$4439</td> </tr> <tr> <td data-bbox="196 1346 448 1373">CD5010AY</td> <td data-bbox="448 1346 727 1373">Not Available</td> </tr> <tr> <td data-bbox="196 1377 448 1404">CD6000-CD6900</td> <td data-bbox="448 1377 727 1404">Refer to Wolong</td> </tr> </tbody> </table> <p data-bbox="196 1415 461 1442">* Subject to engineering approval</p>	Motor Frame Size	List Price Addition Duty "A"	CDL182AT-CD189AT	Not Available	CD218AT-CD2110AT	\$892	CD258AT-CD259AT	\$1136	CD287AT-CD288AT	\$1403	CD327AT-CD328AT*	\$1631	CD329AT	Not Available	CD365AT-CD368AT	\$2123	CD407AT-CD409AT	\$2645	CD504AT-CD508AT	\$4439	CD5010AY	Not Available	CD6000-CD6900	Refer to Wolong
Motor Frame Size	List Price Addition Duty "A"																								
CDL182AT-CD189AT	Not Available																								
CD218AT-CD2110AT	\$892																								
CD258AT-CD259AT	\$1136																								
CD287AT-CD288AT	\$1403																								
CD327AT-CD328AT*	\$1631																								
CD329AT	Not Available																								
CD365AT-CD368AT	\$2123																								
CD407AT-CD409AT	\$2645																								
CD504AT-CD508AT	\$4439																								
CD5010AY	Not Available																								
CD6000-CD6900	Refer to Wolong																								
24	<p>SHAFT EXTENSIONS</p>																								
24a	<p>Standard Single Shaft Extension. Dimensions will be as shown on dimension prints.</p>																								
24b	<p>Standard Double Shaft Extension. Dimensions will be as shown on dimension prints.</p>																								
24c	<p>Standard Oversize Single Drive End Shaft Extension. Standard shaft extension of the next larger frame diameter for CD210AT-CD360AT. Oversize shafts are not available on Explosion-proof Motors. See table in Item 24d for CD400AT and CD500AT frames. On CD5010AY frame, the standard drive end shaft is oversize (4.125 in. dia.), no price addition. For overhung loads, refer to Wolong. Where standard oversize shaft is used, oversize bearing is included in price.</p>																								

Accessories and Modifications

Accessories and Modifications

CD180AT through CD6900

ITEM	DESCRIPTION
------	-------------

24d Standard Oversize Double Shaft Extension. Standard double shaft extension of the next larger frame diameter for CD210AT-CD360AT. Oversize shafts are not available on Explosion-proof Motors. For overhung loads, refer to Wolong. Oversize shafts for CD400AT-CD500AT are as follows:

Frame	OVERSIZE SHAFT DIAMETER (inches)	
	Commutator End	Drive End
CD400AT	2.625	2.875
CD504AT-CD508AT	3.25	3.75
CD5010AY	No additional oversize shaft available. See dimension prints for standard shaft.	

Note: With oversize shafts, the shaft length may be longer and the overall machine length may be longer. Refer to Wolong for exact dimensions.

24e Shaft Extension, Special. Special straight extensions on drive end or commutator end or both. The desired dimension must be specified when ordered. The special diameter must not exceed the oversize diameter where an oversize shaft is available.

On CD6000 frame the special shaft diameter must not exceed the standard shaft diameter.

If required, pricing for oversize bearing must also be added.

CAUTION:

Belted drives using smaller than standard diameter shafts and/or longer than standard shafts must be referred to GE with complete belt drive data.

MOTOR LIST PRICE

SHAFT EXTENSION	Up to \$2500	\$2501 to \$3592	\$3593 to \$5578	\$5579 to \$9748	\$9749 to \$13218	\$13219 to \$23922	\$23923 to \$42136	\$42137 to \$61750	\$61751 to \$98628	\$98629 to \$157704	\$157704 to \$252288	\$252289 to \$403650	\$403651 and up
	List Price Addition												
a. Standard Single Shaft Extension	Furnished as standard on all motors and generators. No price addition for larger frame size generators where double shaft is standard.												
b. Standard Double Shaft Extension	\$70	\$82	\$96	\$150	\$244	\$352	\$420	\$594	\$676	On CD6000-CD6900, no adder required			
c. Standard Oversize Single Drive End Shaft Extension	Not available on CD180AT frames.			\$366	\$468	\$574	\$680	\$766	\$892	Not available on CD6000-CD6900 frames.			
d. Standard Oversize Double Shaft Extension	Not available on CD180AT frames.			\$732	\$936	\$1148	\$1360	\$1532	\$1782	Not available on CD6000-CD6900 frames.			
e. Shaft Extension, Special	\$488	\$488	\$488	\$488	\$680	\$788	\$972	\$1272	\$1784	\$2520	\$2520	\$5040	\$5040

Accessories and Modifications

CD180AT through CD6900

ITEM	DESCRIPTION																				
25	<p>SHAFT GROUNDING BRUSH A shaft grounding brush is recommended to minimize possible bearing failures caused by shaft voltages. It is mounted externally on the drive end of CD218AT-CD5010AY frames (which reduces usable drive end shaft length by approximately 1 inch) and is mounted internally on the drive end of CD6000-CD6900 frames. Note: The shaft grounding brush and labyrinth seal are furnished as standard with papermill features.</p> <table border="1" data-bbox="203 562 682 745"> <thead> <tr> <th>Motor Frame Size</th> <th>List Price Addition</th> </tr> </thead> <tbody> <tr> <td>CD180AT</td> <td>Not Available</td> </tr> <tr> <td>CD210AT</td> <td>\$1448</td> </tr> <tr> <td>CD250AT-CD320AT</td> <td>\$1676</td> </tr> <tr> <td>CD360AT-CD5010AY</td> <td>\$2024</td> </tr> <tr> <td>CD6000-CD6900</td> <td>\$1186</td> </tr> </tbody> </table> <p>N/A on C-face, D-flange or P-base motors. Use TACH options. Price addition includes labyrinth seal on CD218AT-CD5010AY frames. See page 3.18, Item 22 for labyrinth seal on CD6000-CD6900 frames.</p>			Motor Frame Size	List Price Addition	CD180AT	Not Available	CD210AT	\$1448	CD250AT-CD320AT	\$1676	CD360AT-CD5010AY	\$2024	CD6000-CD6900	\$1186						
Motor Frame Size	List Price Addition																				
CD180AT	Not Available																				
CD210AT	\$1448																				
CD250AT-CD320AT	\$1676																				
CD360AT-CD5010AY	\$2024																				
CD6000-CD6900	\$1186																				
26	<p>SPACE HEATERS Note: Furnished as standard with crane duty feature Space heaters are installed inside the machine with leads brought out through the standard conduit box. Single phase AC and DC ratings available are 120, 240, and 480 Volts on frames CD180AT-CD6900. Refer to Wolong for higher voltage.</p> <table border="1" data-bbox="203 961 1039 1144"> <thead> <tr> <th>Motor Frame Size</th> <th>Wattage</th> <th>List Price Addition</th> </tr> </thead> <tbody> <tr> <td>CD180AT-CD210AT</td> <td>30</td> <td>\$582</td> </tr> <tr> <td>CD250AT-CD320AT</td> <td>75</td> <td>\$582</td> </tr> <tr> <td>CD360AT-CD5010AY</td> <td>180</td> <td>\$582</td> </tr> <tr> <td>CD6000-CD6100</td> <td>500</td> <td>\$1658</td> </tr> <tr> <td>CD6200-CD6900</td> <td>1000</td> <td>\$1658</td> </tr> </tbody> </table>			Motor Frame Size	Wattage	List Price Addition	CD180AT-CD210AT	30	\$582	CD250AT-CD320AT	75	\$582	CD360AT-CD5010AY	180	\$582	CD6000-CD6100	500	\$1658	CD6200-CD6900	1000	\$1658
Motor Frame Size	Wattage	List Price Addition																			
CD180AT-CD210AT	30	\$582																			
CD250AT-CD320AT	75	\$582																			
CD360AT-CD5010AY	180	\$582																			
CD6000-CD6100	500	\$1658																			
CD6200-CD6900	1000	\$1658																			
27	<p>SPEED LIMIT DEVICE Provides for addition of calibrated speed limit device (non-adjustable on frames CD508AT and below and adjustable on frames CD5010AY and above) for motor over speed protection when connected in proper circuit. The device is flange mounted on the commutator end of the motor. Contact will be normally closed on frames CD508AT and below. On frames CD5010AY and above, both normally open and normally closed contacts are provided. The device will be set at the factory to operate at 13-17% above the top rated speed. For special limiting speed, refer to Wolong. Note: Non-adjustable speed limit devices are not recommended for crane duty use. If adjustable speed limit switch is required on frames CDL182AT-CD508AT, refer to Wolong.</p> <table border="1" data-bbox="191 1430 987 1669"> <thead> <tr> <th rowspan="3">SPEED LIMIT DEVICE</th> <th colspan="2">MOTOR FRAME SIZE</th> </tr> <tr> <th>CD182AT-CD508AT</th> <th>CD5010AY-CD6900</th> </tr> <tr> <th colspan="2">List Price Addition</th> </tr> </thead> <tbody> <tr> <td>a. Speed limit device (mounted)</td> <td>\$2534</td> <td>\$5982</td> </tr> <tr> <td>b. Speed limit device (mounted) with double shaft extension</td> <td>Refer to Wolong</td> <td>\$5982</td> </tr> <tr> <td>c. Euclid speed switch</td> <td>\$7646</td> <td>\$8480</td> </tr> </tbody> </table> <div data-bbox="1003 1430 1503 1766" data-label="Image"> </div> <p>Speed Limit Devices are available on all frames with a single or double shaft extension. (Frame CD5010AY shown above with double shaft extension.)</p>			SPEED LIMIT DEVICE	MOTOR FRAME SIZE		CD182AT-CD508AT	CD5010AY-CD6900	List Price Addition		a. Speed limit device (mounted)	\$2534	\$5982	b. Speed limit device (mounted) with double shaft extension	Refer to Wolong	\$5982	c. Euclid speed switch	\$7646	\$8480		
SPEED LIMIT DEVICE	MOTOR FRAME SIZE																				
	CD182AT-CD508AT	CD5010AY-CD6900																			
	List Price Addition																				
a. Speed limit device (mounted)	\$2534	\$5982																			
b. Speed limit device (mounted) with double shaft extension	Refer to Wolong	\$5982																			
c. Euclid speed switch	\$7646	\$8480																			

Accessories and Modifications

Accessories and Modifications

CD180AT through CD6900

Accessories and Modifications

ITEM	DESCRIPTION																			
28	SPEED RANGE GREATER THAN STANDARD BY FIELD CONTROL*																			
	Provides for increased speed range by field control with constant horsepower output. For top speeds not listed, use the price of the next higher top speed listed. The frame size may be different from standard. On single phase power supply, refer to Wolong . The overloads to these speeds are defined in page 3.17, Item 20. All Voltages, Continuous or Short Time Rated Drip-proof Fully Guarded and Totally Enclosed																			
	Base Speed RPM	Rated Top Speed RPM	HORSEPOWER																	
			3 and Below	5	7.5	10	15	20	25	30	40	50	60	75	100	125	150	200	250	
PERCENTAGE ADDITION TO LIST PRICE OF BASIC MOTOR																				
2500	3500	10	10	10	10	10	10	10	10	10	15	20								
1750	2500	10	10	10	10	10	10	10	10	10	10	10	10	10	15	15	15	15	15	
	2900	10	10	10	10	10	10	10	10	10	15	15	15	15	20	20	20	20		
	3000	10	10	10	10	10	10	10	10	10	15	15	15	15	20	20				
	3500	15	15	15	15	15	15	15	15	20	20	20	20							
1500	1900	0	0	0	0	0	0	0	0	0	0	0	0	0	0	0	0	10	10	
	2300	10	10	10	10	10	10	10	10	10	10	10	10	10	15	15	15	15	15	
	2600	10	10	10	10	10	10	10	10	15	15	15	15	15	20	20	20			
	2900	10	10	10	10	10	15	15	15	15	15	20	20	20						
	3100	15	15	15	15	15	15	15	15	20	20	20	20							
	3200	15	15	15	15	15	20	20	20	25	25	25	25							
1150	2000	0	0	0	0	0	0	0	0	0	0	0	0	0	0	0	0	10	10	
	2300	10	10	10	10	10	10	10	10	10	10	10	10	15	15	15	20	20	20	
	2550	10	10	15	15	15	15	15	15	15	15	20	20	20	20	20	20	20	20	
	2900	10	10	15	15	15	15	15	15	15	15	20	20	20	20					
	3450	15	20	20	20	20	20	20	25	25	25	25	25							
850	2000	10	10	10	10	10	10	10	10	10	10	10	10	10	10	10	15	15	15	
	2200	10	10	10	10	15	15	15	15	15	15	15	15	15	15	15	15	15	15	
	2550	10	10	10	10	15	15	15	15	15	15	15	20	20	20	20	20	20	20	
	3400	15	15	15	15	15	20	20	20	25	25	25	25							
650	2000	10	10	10	10	10	10	10	10	10	10	10	10	10	15	15	15	15	15	
	2200	15	15	15	15	15	15	15	15	15	15	15	15	15	15	15	15	15	15	
	2550	15	15	15	15	15	15	15	15	20	20	20	20	20	20	20	20	20	20	
	2600	15	15	15	15	15	15	15	15	20										
500	2000	10	10	10	10	10	10	10	10	10	10	10	10	15	15	15	15	20	20	
	2200	15	15	15	15	15	15	15	15	15	15	15	15	15	15	15	20	20	20	
	2500	15	15	15	15	15	15	15	15	15	15	15	15	15	20					
400	1600	10	10	10	10	10	10	10	10	10	10	10	10	10	10	10	15	15	15	
	1900	10	10	15	15	15	15	15	15	15	15	15	15	15	15	15	20	20	20	
	2200	15	15	20	20	20	20	20	20	20	20	20	20	20	20	20	25			
	2400	20	20	20	20	20	20	20	20	20	20	20	20							
300	1200	10	10	10	10	10	10	10	10	10	10	10	10	10	10	10	10	10	10	
	1500	15	15	15	15	15	15	15	15	15	15	15	15	15	15	15	15	15	15	
	1800	15	15	15	15	15	15	15	15	15	20	20	20	20	20	20	20	20	20	
250	800	Refer to Factory										2	2	2	2	2	2	2	2	2
	900											2	2	2	2	2	2	2	2	
	1000											4	4	4	4	4	4	4	4	
	1100											6	6	6	6	6	6	6	6	
	1200											8	8	8	8	8	8	8	8	
	1250											10	10	10	10	10	10	10	10	
	1300											12.5	12.5	12.5	12.5	12.5	12.5	12.5	12.5	
	1350											15	15	15	15	15	15	15	15	
	1400											17.5	17.5	17.5	17.5	17.5	17.5	17.5	17.5	
	1500											20	20	20	20	20	20	20	20	

* Contact **Wolong** for design verification (affected by ambient, overload, Class B rise, etc.)

Accessories and Modifications

CD180AT through CD6900

ITEM	DESCRIPTION																																																																																		
28a	SPEED RANGE GREATER THAN STANDARD BY FIELD CONTROL																																																																																		
	Provides for increased speed range by field control with constant horsepower output. For top speeds not listed, use the price of the next higher top speed listed. The frame size may be different from standard. On single-phase power supply, refer to Wolong. The overloads to these speeds are defined in page 3.17, Item 20.																																																																																		
	All Voltages, Continuous or Short Time Rated Drip-proof Fully Guarded and Totally Enclosed																																																																																		
	<table border="1"> <thead> <tr> <th rowspan="2">Base Speed RPM</th> <th rowspan="2">Rated Top Speed RPM</th> <th colspan="3">HORSEPOWER</th> </tr> <tr> <th>300</th> <th>400</th> <th>500</th> </tr> </thead> <tbody> <tr> <td colspan="5" style="text-align: center;">PERCENTAGE ADDITION TO LIST PRICE OF BASIC MOTOR</td> </tr> </tbody> </table>					Base Speed RPM	Rated Top Speed RPM	HORSEPOWER			300	400	500	PERCENTAGE ADDITION TO LIST PRICE OF BASIC MOTOR					<table border="1"> <thead> <tr> <th rowspan="2">Base Speed RPM</th> <th rowspan="2">Rated Top Speed RPM</th> <th colspan="3">HORSEPOWER</th> </tr> <tr> <th>300</th> <th>400</th> <th>500</th> </tr> </thead> <tbody> <tr> <td colspan="5" style="text-align: center;">PERCENTAGE ADDITION TO LIST PRICE OF BASIC MOTOR</td> </tr> </tbody> </table>					Base Speed RPM	Rated Top Speed RPM	HORSEPOWER			300	400	500	PERCENTAGE ADDITION TO LIST PRICE OF BASIC MOTOR																																																			
	Base Speed RPM	Rated Top Speed RPM	HORSEPOWER																																																																																
			300	400	500																																																																														
	PERCENTAGE ADDITION TO LIST PRICE OF BASIC MOTOR																																																																																		
	Base Speed RPM	Rated Top Speed RPM	HORSEPOWER																																																																																
			300	400	500																																																																														
	PERCENTAGE ADDITION TO LIST PRICE OF BASIC MOTOR																																																																																		
<table border="1"> <tbody> <tr> <td rowspan="3">1750</td> <td>1900</td> <td>0</td> <td>0</td> <td>0</td> </tr> <tr> <td>2000</td> <td>10</td> <td>10</td> <td>10</td> </tr> <tr> <td>2200</td> <td>10</td> <td>10</td> <td>10</td> </tr> </tbody> </table>					1750	1900	0	0	0	2000	10	10	10	2200	10	10	10	<table border="1"> <tbody> <tr> <td rowspan="10">400</td> <td>1000</td> <td>0</td> <td>0</td> <td>0</td> </tr> <tr> <td>1100</td> <td>0</td> <td>4</td> <td>4</td> </tr> <tr> <td>1200</td> <td>0</td> <td>4</td> <td>6</td> </tr> <tr> <td>1300</td> <td>6</td> <td>6</td> <td>8</td> </tr> <tr> <td>1400</td> <td>10</td> <td>10</td> <td>12.5</td> </tr> <tr> <td>1500</td> <td>12.5</td> <td>12.5</td> <td>15</td> </tr> <tr> <td>1600</td> <td>15</td> <td>15</td> <td>17.5</td> </tr> <tr> <td>1700</td> <td>15</td> <td>17.5</td> <td>20</td> </tr> <tr> <td>1800</td> <td>17.5</td> <td>20</td> <td>22.5</td> </tr> <tr> <td>1900</td> <td>20</td> <td></td> <td></td> </tr> </tbody> </table>					400	1000	0	0	0	1100	0	4	4	1200	0	4	6	1300	6	6	8	1400	10	10	12.5	1500	12.5	12.5	15	1600	15	15	17.5	1700	15	17.5	20	1800	17.5	20	22.5	1900	20																						
1750	1900	0	0	0																																																																															
	2000	10	10	10																																																																															
	2200	10	10	10																																																																															
400	1000	0	0	0																																																																															
	1100	0	4	4																																																																															
	1200	0	4	6																																																																															
	1300	6	6	8																																																																															
	1400	10	10	12.5																																																																															
	1500	12.5	12.5	15																																																																															
	1600	15	15	17.5																																																																															
	1700	15	17.5	20																																																																															
	1800	17.5	20	22.5																																																																															
	1900	20																																																																																	
<table border="1"> <tbody> <tr> <td rowspan="7">1500</td> <td>1800</td> <td>0</td> <td>0</td> <td>6</td> </tr> <tr> <td>1900</td> <td>10</td> <td>10</td> <td>10</td> </tr> <tr> <td>2000</td> <td>15</td> <td>15</td> <td>15</td> </tr> <tr> <td>2100</td> <td>15</td> <td>15</td> <td>15</td> </tr> <tr> <td>2200</td> <td>15</td> <td></td> <td></td> </tr> <tr> <td>2300</td> <td>20</td> <td></td> <td></td> </tr> </tbody> </table>					1500	1800	0	0	6	1900	10	10	10	2000	15	15	15	2100	15	15	15	2200	15			2300	20			<table border="1"> <tbody> <tr> <td rowspan="10">300</td> <td>750</td> <td>0</td> <td>0</td> <td>0</td> </tr> <tr> <td>900</td> <td>0</td> <td>4</td> <td>4</td> </tr> <tr> <td>1000</td> <td>4</td> <td>4</td> <td>4</td> </tr> <tr> <td>1100</td> <td>6</td> <td>6</td> <td>8</td> </tr> <tr> <td>1200</td> <td>10</td> <td>10</td> <td>12.5</td> </tr> <tr> <td>1300</td> <td>12.5</td> <td>12.5</td> <td>17.5</td> </tr> <tr> <td>1400</td> <td>12.5</td> <td>17.5</td> <td>20</td> </tr> <tr> <td>1500</td> <td>17.5</td> <td>20</td> <td>22.5</td> </tr> <tr> <td>1600</td> <td>20</td> <td></td> <td></td> </tr> <tr> <td>1700</td> <td>22.5</td> <td></td> <td></td> </tr> </tbody> </table>					300	750	0	0	0	900	0	4	4	1000	4	4	4	1100	6	6	8	1200	10	10	12.5	1300	12.5	12.5	17.5	1400	12.5	17.5	20	1500	17.5	20	22.5	1600	20			1700	22.5										
1500	1800	0	0	6																																																																															
	1900	10	10	10																																																																															
	2000	15	15	15																																																																															
	2100	15	15	15																																																																															
	2200	15																																																																																	
	2300	20																																																																																	
	300	750	0	0	0																																																																														
900		0	4	4																																																																															
1000		4	4	4																																																																															
1100		6	6	8																																																																															
1200		10	10	12.5																																																																															
1300		12.5	12.5	17.5																																																																															
1400		12.5	17.5	20																																																																															
1500		17.5	20	22.5																																																																															
1600		20																																																																																	
1700		22.5																																																																																	
<table border="1"> <tbody> <tr> <td rowspan="8">1150</td> <td>1500</td> <td>0</td> <td>0</td> <td>0</td> </tr> <tr> <td>1600</td> <td>0</td> <td>4</td> <td>4</td> </tr> <tr> <td>1700</td> <td>6</td> <td>6</td> <td>6</td> </tr> <tr> <td>1800</td> <td>8</td> <td>8</td> <td>8</td> </tr> <tr> <td>1900</td> <td>12.5</td> <td>12.5</td> <td>12.5</td> </tr> <tr> <td>2000</td> <td>15</td> <td>15</td> <td>15</td> </tr> <tr> <td>2100</td> <td>17.5</td> <td>17.5</td> <td>17.5</td> </tr> <tr> <td>2200</td> <td>17.5</td> <td>17.5</td> <td>17.5</td> </tr> </tbody> </table>					1150	1500	0	0	0	1600	0	4	4	1700	6	6	6	1800	8	8	8	1900	12.5	12.5	12.5	2000	15	15	15	2100	17.5	17.5	17.5	2200	17.5	17.5	17.5	<table border="1"> <tbody> <tr> <td rowspan="10">250</td> <td>710</td> <td>0</td> <td>0</td> <td>0</td> </tr> <tr> <td>750</td> <td>0</td> <td>1</td> <td>1</td> </tr> <tr> <td>800</td> <td>2</td> <td>2</td> <td>2</td> </tr> <tr> <td>900</td> <td>2</td> <td>2</td> <td>4</td> </tr> <tr> <td>1000</td> <td>4</td> <td>6</td> <td>8</td> </tr> <tr> <td>1100</td> <td>6</td> <td>10</td> <td>12.5</td> </tr> <tr> <td>1200</td> <td>10</td> <td>15</td> <td>17.5</td> </tr> <tr> <td>1250</td> <td>12.5</td> <td>17.5</td> <td>17.5</td> </tr> <tr> <td>1300</td> <td>15</td> <td>17.5</td> <td>17.5</td> </tr> <tr> <td>1350</td> <td>17.5</td> <td>20</td> <td>20</td> </tr> </tbody> </table>					250	710	0	0	0	750	0	1	1	800	2	2	2	900	2	2	4	1000	4	6	8	1100	6	10	12.5	1200	10	15	17.5	1250	12.5	17.5	17.5	1300	15	17.5	17.5	1350	17.5	20	20
1150	1500	0	0	0																																																																															
	1600	0	4	4																																																																															
	1700	6	6	6																																																																															
	1800	8	8	8																																																																															
	1900	12.5	12.5	12.5																																																																															
	2000	15	15	15																																																																															
	2100	17.5	17.5	17.5																																																																															
	2200	17.5	17.5	17.5																																																																															
250	710	0	0	0																																																																															
	750	0	1	1																																																																															
	800	2	2	2																																																																															
	900	2	2	4																																																																															
	1000	4	6	8																																																																															
	1100	6	10	12.5																																																																															
	1200	10	15	17.5																																																																															
	1250	12.5	17.5	17.5																																																																															
	1300	15	17.5	17.5																																																																															
	1350	17.5	20	20																																																																															
<table border="1"> <tbody> <tr> <td rowspan="7">850</td> <td>1500</td> <td>0</td> <td>0</td> <td>4</td> </tr> <tr> <td>1600</td> <td>4</td> <td>6</td> <td>8</td> </tr> <tr> <td>1700</td> <td>8</td> <td>8</td> <td>10</td> </tr> <tr> <td>1800</td> <td>10</td> <td>10</td> <td>12.5</td> </tr> <tr> <td>1900</td> <td>12.5</td> <td>12.5</td> <td>15</td> </tr> <tr> <td>2000</td> <td>15</td> <td>15</td> <td>17.5</td> </tr> <tr> <td>2100</td> <td>17.5</td> <td>17.5</td> <td>20</td> </tr> </tbody> </table>					850	1500	0	0	4	1600	4	6	8	1700	8	8	10	1800	10	10	12.5	1900	12.5	12.5	15	2000	15	15	17.5	2100	17.5	17.5	20	<table border="1"> <tbody> <tr> <td rowspan="10">500</td> <td>1000</td> <td>0</td> <td>0</td> <td>0</td> </tr> <tr> <td>1100</td> <td>0</td> <td>0</td> <td>4</td> </tr> <tr> <td>1200</td> <td>0</td> <td>0</td> <td>4</td> </tr> <tr> <td>1300</td> <td>0</td> <td>4</td> <td>6</td> </tr> <tr> <td>1400</td> <td>4</td> <td>6</td> <td>8</td> </tr> <tr> <td>1500</td> <td>6</td> <td>10</td> <td>12.5</td> </tr> <tr> <td>1600</td> <td>12.5</td> <td>12.5</td> <td>15</td> </tr> <tr> <td>1700</td> <td>15</td> <td>15</td> <td>17.5</td> </tr> <tr> <td>1800</td> <td>15</td> <td>17.5</td> <td>20</td> </tr> <tr> <td>1900</td> <td>17.5</td> <td></td> <td></td> </tr> </tbody> </table>					500	1000	0	0	0	1100	0	0	4	1200	0	0	4	1300	0	4	6	1400	4	6	8	1500	6	10	12.5	1600	12.5	12.5	15	1700	15	15	17.5	1800	15	17.5	20	1900	17.5						
850	1500	0	0	4																																																																															
	1600	4	6	8																																																																															
	1700	8	8	10																																																																															
	1800	10	10	12.5																																																																															
	1900	12.5	12.5	15																																																																															
	2000	15	15	17.5																																																																															
	2100	17.5	17.5	20																																																																															
500	1000	0	0	0																																																																															
	1100	0	0	4																																																																															
	1200	0	0	4																																																																															
	1300	0	4	6																																																																															
	1400	4	6	8																																																																															
	1500	6	10	12.5																																																																															
	1600	12.5	12.5	15																																																																															
	1700	15	15	17.5																																																																															
	1800	15	17.5	20																																																																															
	1900	17.5																																																																																	
<table border="1"> <tbody> <tr> <td rowspan="8">650</td> <td>1400</td> <td>0</td> <td>0</td> <td>4</td> </tr> <tr> <td>1500</td> <td>0</td> <td>4</td> <td>6</td> </tr> <tr> <td>1600</td> <td>4</td> <td>6</td> <td>10</td> </tr> <tr> <td>1700</td> <td>10</td> <td>10</td> <td>12.5</td> </tr> <tr> <td>1800</td> <td>10</td> <td>12.5</td> <td></td> </tr> <tr> <td>1900</td> <td>12.5</td> <td>15</td> <td></td> </tr> <tr> <td>2000</td> <td>15</td> <td></td> <td></td> </tr> <tr> <td>2100</td> <td>17.5</td> <td></td> <td></td> </tr> </tbody> </table>					650	1400	0	0	4	1500	0	4	6	1600	4	6	10	1700	10	10	12.5	1800	10	12.5		1900	12.5	15		2000	15			2100	17.5																																																
650	1400	0	0	4																																																																															
	1500	0	4	6																																																																															
	1600	4	6	10																																																																															
	1700	10	10	12.5																																																																															
	1800	10	12.5																																																																																
	1900	12.5	15																																																																																
	2000	15																																																																																	
	2100	17.5																																																																																	

Accessories and Modifications

Accessories and Modifications

CD180AT through CD6900

ITEM	DESCRIPTION
------	-------------

29 TACHOMETER GENERATORS

29a SPEED RANGES

The following tachometer generator operating speeds are available with listed items:

Type	Tachometer Output	Operating Range
BC42	50 Volts/1000 RPM 100 Volts/1000 RPM	100-5000 RPM 100-2750 RPM
BC46	50 Volts/1000 RPM 100 Volts/1000 RPM 200 Volts/1000 RPM	100-5000 RPM 100-3600 RPM 100-1800 RPM
Form Y	50 Volts/1000 RPM 100 Volts/1000 RPM	100-5000 RPM 100-2500 RPM
AN-AC	90 Volts/1000 RPM	100-5000 RPM



BC tachometers produce DC output to provide high accuracy speed regulation or speed indication.



PY tachometers provide a medium accuracy DC output for use with a regulated drive or for speed indication.



AN Series tachometers provide a compact construction with thru-shaft capabilities. The AN Series tachometers can be furnished with either AC or digital output signal for speed regulation or speed indication. (Type AN-DG tachometer shown above.)

Accessories and Modifications

CD180AT through CD6900

ITEM	DESCRIPTION													
29b	MOTOR MOUNTED, DIRECT CONNECTED TACHOMETERS													
	MOTOR FRAME SIZE CDL182AT-CD5010AY CD6000-CD6900 List Price Addition													
	<p>TYPE BC ^{②③} A DC tachometer for high accuracy speed-indicating and/or speed-regulating applications. The tachometer generator is flange mounted, rabbeted to the commutator end-shield, and is coupled with an anti-backlash coupling to the motor shaft extension. The BC tachometer generators will have a footed frame and commutator end extension covered by a thimble. This allows belt driving a second tachometer mounted on the BC feet and simplifies customer tachometer standardization. Any other arrangement should be referred to Wolong. Note: A double shaft extension is not available on severe duty or explosion proof BC tachometers.</p> <p>Type BC BC42, 50 or 100 Volts/1000 RPM BC46, 50, 100 or 200 Volts/1000 RPM</p> <p>Type BC, Waterproof or Dustproof BC42, 100 Volts/1000 RPM BC46, 100 Volts/1000 RPM</p> <p>Type BC, Explosionproof (Class I, Group D, Class II, Groups E, F, G) BC42, 50 or 100 Volts/1000 RPM</p> <p>Mounting kit is assembled to motor and is only for flange mounted BC tachometer. (This includes coupling, stub shaft, and mounting bracket for BC tach.) For explosionproof tachometer to be mounted on explosionproof motor, refer to page 2.24.</p>	<p>OUTLINE PAGE 4.60</p> <table border="0"> <tr> <td>\$7440</td> <td>\$8333</td> </tr> <tr> <td>\$10008</td> <td>\$11209</td> </tr> <tr> <td>\$8194</td> <td>\$9117</td> </tr> <tr> <td>\$10728</td> <td>\$11562</td> </tr> <tr> <td>\$10400</td> <td>\$11645</td> </tr> <tr> <td>\$1666</td> <td>\$2500</td> </tr> </table>	\$7440	\$8333	\$10008	\$11209	\$8194	\$9117	\$10728	\$11562	\$10400	\$11645	\$1666	\$2500
\$7440	\$8333													
\$10008	\$11209													
\$8194	\$9117													
\$10728	\$11562													
\$10400	\$11645													
\$1666	\$2500													
	<p>FORM Y, DC ^{②③} A DC tachometer for medium accuracy speed-indicating and/or speed-regulating applications. The tachometer generator is flange mounted and rabbeted to the commutator endshield, and is coupled with an antibacklash coupling to the motor shaft extension. (Not available as waterproof.)</p> <p>5PY59JY, 50 or 100 Volts/1000 RPM (max speed 2500 RPM)</p> <p>Mounting kit is assembled to motor and is only for flange mounted PY tachometer. (This includes coupling, stub shaft, and mounting bracket for Form Y.)</p>	<p>OUTLINE PAGE 4.61</p> <table border="0"> <tr> <td>\$4925</td> <td>\$5516</td> </tr> <tr> <td>\$1666</td> <td>\$2500</td> </tr> </table>	\$4925	\$5516	\$1666	\$2500								
\$4925	\$5516													
\$1666	\$2500													
	<p>TYPE AN-AC ^{②④} An AC tachometer for medium accuracy speed-indicating or for use with some speed-regulating systems. The tachometer generator is flange mounted and rabbeted to the commutator endshield. (Not available for separate mounting or belt connection.)</p> <p>45/90 Volts/1000 RPM (For frames CD180AT-CD6200 only, including CD180AT and CD210AT TEFC enclosures.)</p>	<p>OUTLINE PAGE 4.55</p> <table border="0"> <tr> <td>\$1784</td> <td>\$4222 ^{②④}</td> </tr> </table>	\$1784	\$4222 ^{②④}										
\$1784	\$4222 ^{②④}													
	<p>^{②③} CD180AT and CD210AT TEFC motors suitable only for AN tachometer mounting on commutator end. ^{②④} Not available on CD6700-CD6900.</p>													

Accessories and Modifications

Accessories and Modifications

CD180AT through CD6900

Accessories and Modifications

ITEM	DESCRIPTION					
29b Cont'd	MOTOR MOUNTED, DIRECT CONNECTED TACHOMETERS	MOTOR FRAME SIZE				
		CD182AT- CD5010AY	CD6000- CD6900			
	MODEL NUMBER AND DESCRIPTION		List Price Addition		Environmental Rating	
	Avtron AV85 THIN-LINE II™ (Replaces M85) Style tachometer/encoder. Mounts on 8.5" accessory flange. No bearings, couplings, or adapters. Magnetostrictive (MR) sensors, Wide-Gap technology, full wiring protection and LED diagnostics.		OUTLINE PAGE 4.54		Heavy Duty Industrial Applications with frequent exposure to temperatures variations and contamination. Paper, metals processing, plastics, textiles, food, petrochemical, machine tool, marine duty, material handling	
			240, 600, 1024, 1200 pulses/revolution, single output	\$3285		\$5805
			240, 600, 1024, 1200 pulses/revolution, dual output	\$5468		\$7988
			2000, 2048, 4096, 5000 pulses/revolution, single output	\$3641		\$6156
			2000, 2048, 4096, 5000 pulses/revolution, dual output	\$6174		\$8690
	Avtron AV485 SMARTach II™ (Replaces M3 and M4 solid-shaft, M385, M485, M785) Style tachometer/encoder. NEMA 56C motor face mount (like BC). MR sensors, full wiring protection and LED diagnostics, removable sensors.		OUTLINE PAGE 4.53		Severe Duty Industrial Applications with constant exposure to temperature variations and contamination, and increased physical demands occur. Paper, primary metals, petrochemical, mining, dockside cranes, marine duty, wash down; Ideal for MD style motors.	
			240, 600, 1024, 1200 pulses/revolution, single output	\$5945		\$5945
240, 600, 1024, 1200 pulses/revolution, dual output			\$8721	\$8721		
2000, 2048, 4096, 5000 pulses/revolution, single output			\$6080	\$6080		
2000, 2048, 4096, 5000 pulses/revolution, dual output			\$9000	\$9000		
TYPE AN-DG Avtron AV850 SMARTach II (Replaces AN-DG, M193B, M285) Mounts on 8.5" accessory flange. No bearings, couplings or adapters. MR sensors, Wide-Gap technology, full wiring protection and LED diagnostics. Removable sensors. Shaft grounding brush option or permits thru-shafts up to 4.5"		OUTLINE PAGE 4.53		Heavy Duty Industrial Applications with frequent exposure to temperatures variations and contamination. Paper, metals processing, plastics, textiles, food, petrochemical, machine tool, marine duty, material handling.		
		240, 600, 1024, 1200 pulses/revolution, single output	\$4824		\$6480	
		240, 600, 1024, 1200 pulses/revolution, dual output	\$7034		\$8690	
		2000, 2048, 4096, 5000 pulses/revolution, single output	\$4959		\$6620	
		2000, 2048, 4096, 5000 pulses/revolution, dual output	\$7308		\$8969	
		Add shaft grounding brush to AV850	\$878		\$2534	
Avtron AV685 SMARTach II (Replaces M685) Mounts on stub shaft (tethered). MR sensors, full wiring protection and LED diagnostics, removable sensors.		OUTLINE PAGE 4.54		Severe Duty Industrial Applications with constant exposure to temperature variations and contamination and increased physical demands occur. Paper, primary metals, petrochemical, mining, dockside cranes, marine duty, wash down. Ideal for MD style motors.		
		240, 600, 1024, 1200 pulses/revolution, single output	\$6881		\$6881	
		240, 600, 1024, 1200 pulses/revolution, dual output	\$9338		\$9338	
		2000, 2048, 4096, 5000 pulses/revolution, single output	\$7187		\$7187	
		2000, 2048, 4096, 5000 pulses/revolution, dual output	\$9950		\$9950	
		Add shaft grounding brush to AV685	\$1319		\$1319	
Notes: Avtron AV850 SMARTach II can not be mounted on CD250AT-CD320AT frames with a TEFC enclosure. Use a TENV or TEAO enclosure. Avtron AV850, AV485 can not be mounted on CD180AT and CD210AT TEFC motors. Use a TENV enclosure. Integral end of shaft grounding brush, add \$2232 list to the above prices. Not available on tachs with thru shafts. (ppr) pulses per revolution, required at time of order						

Accessories and Modifications

CD180AT through CD6900

ITEM	DESCRIPTION			
29b Cont'd	MOTOR MOUNTED, DIRECT CONNECTED TACHOMETERS	MOTOR FRAME SIZE		
		CDL182AT- CD5010AY	CD6000- CD6900	
MODEL NUMBER AND DESCRIPTION		List Price Addition		Environmental Rating
NorthStar RIM Tach® 8500 NexGen (Direct replacement for NorthStar RIM 8500) Mounts on 8.5" accessory flange. No bearings, couplings, or adapters needed. Magneto-resistive sensors, ductile iron enclosure, polymer rotor and industrial connector. For through shaft or end of shaft mountings, the RIM Tach 8500 can fit up to a 4.5" diameter shaft. Features replaceable sensor modules. 240, 512, 600, 1024, 1200 pulses/revolution, single output 240, 512, 600, 1024, 1200 pulses/revolution, dual output		OUTLINE PAGE 4.55 \$4229 \$4829 \$5227 \$5899		Mill Duty Industrial Applications with temperatures between -40°C and +80°C, chemical resistance include salt spray, most solvents, mild acids and bases. Paper, metal finishing, plastics, textiles, converting, machine tools, material handling.
NorthStar RIM Tach® 6200 NexGen (Direct replacement for NorthStar RIM 6200) Foot mount or accessory bracket 56 C-face mount (mounts same as BC style tach). Magneto-resistive sensors, ductile iron enclosure, polymer rotor, industrial connector, extra severe duty bearings for long life. The RIM Tach 6200 is a close coupled design. Features replaceable sensor modules. 240, 512, 600, 1024, 1200, 2048 pulses/revolution, single output 240, 512, 600, 1024, 1200, 2048 pulses/revolution, dual output		OUTLINE PAGE 4.56 \$4780 \$5158 \$5812 \$6277		
NorthStar RIM Tach® 1250 NexGen (Direct replacement for NorthStar RIM 1250) Mounts on 12.5" accessory flange. No bearings, couplings, or adapters needed. Magneto-resistive sensors, ductile iron enclosure, polymer rotor and industrial connector. For a through shaft or end of shaft mountings the RIM Tach 1250 can fit up to a 8.0" diameter shaft. Features replaceable sensor modules. Used on CD6000's. 240, 512, 600, 1024, 1200, 2048 pulses/revolution, single output 240, 512, 600, 1024, 1200, 2048 pulses/revolution, dual output		OUTLINE PAGE 4.57 N/A \$5554 N/A \$6600		Mill Duty Industrial Applications with temperatures between -40°C and +80°C, chemical resistance include salt spray, most solvents, mild acids and bases. Paper, metal finishing, plastics, textiles, converting, machine tools, material handling.
Notes: NorthStar RIM Tach 8500 NexGen can not be mounted on CD180AT-CD320AT frames with a TEFC enclosure. Use a TENV or TEAO enclosure. The NorthStar RIM Tach 1250 NexGen, 6200 NexGen and SLIM Tach® SL85 and HS56 all have sealed electronics to prevent contaminant intrusion. Shaft grounding brush, add \$2232 list to the above prices. All items listed above are CE approved. (ppr) pulses per revolution, required at time of order				

Accessories and Modifications

Accessories and Modifications

CD180AT through CD6900

Accessories and Modifications

ITEM	DESCRIPTION			
29b Cont'd	MOTOR MOUNTED, DIRECT CONNECTED TACHOMETERS	MOTOR FRAME SIZE		
		CD182AT- CD5010AY	CD6000- CD6900	
MODEL NUMBER AND DESCRIPTION		List Price Addition		Environmental Rating
NorthStar SLIM Tach® SL85 (formerly LakeShore) Mounts on 8.5" accessory flange. No bearings, couplings, or adapters needed. Magneto-resistive sensors, ductile iron enclosure, polymer rotor and industrial connector. For through shaft or end of shaft mountings, the SLIM Tach SL85 can fit up to a 3.75" diameter shaft. Approx. half the thickness of the RIM 8500. The SL85 does not have replaceable sensor modules. Through shaft models are also available for shafts ranging from .5" through 3.75" in diameter. 64, 128, 256, 512, 1024 pulses/revolution, single output 64, 128, 256, 512, 1024 pulses/revolution, dual output 2048 pulses/revolution, single output		OUTLINE PAGE 4.56 		Heavy Industrial Industrial Applications with temperatures between -40°C and +80°C, chemical resistance include salt spray, most solvents, mild acids and bases. SL85 can be used in a Mill Duty environment.
NorthStar SLIM Tach HS56 (formerly LakeShore) Hollow shaft design allows for mounting when an accessory flange is not available. Mounts on a standard shaft extension or stub shaft. Magneto-resistive sensors, polymer rotor and industrial connector. SLIM Tach HS56 can fit up to a 1.125" diameter shaft. 64, 128, 256, 512, 1024 pulses/revolution, single output 64, 128, 256, 512, 1024 pulses/revolution, dual output 2048 pulses/revolution, single output 2048 pulses/revolution, dual output		OUTLINE PAGE 4.57 		Industrial Duty Industrial Applications with temperatures between -20°C and +80°C, chemical resistance include salt spray, most solvents, mild acids and bases.
Notes: NorthStar RIM Tach 8500 NexGen can not be mounted on CD180AT-CD320AT frames with a TEFC enclosure. Use a TENV or TEAO enclosure. The NorthStar RIM Tach 1250 NexGen, 6200 NexGen and SLIM Tach SL85 and HS56 all have sealed electronics to prevent contaminant intrusion. Shaft grounding brush, add \$2232 list to the above prices. All items listed above are CE approved. (ppr) pulses per revolution, required at time of order				
Dynapar HA625 Encoder Flange mounted Tach, 5-26 VDC input, push-pull and differential line driver, 5-26 VDC, single output, NEMA 4/IP66 sealed enclosure, side mount MS style connector (10 pin mating connector included) over voltage protection, output short circuit protection, and reverse voltage protection, 85°C operating temperature, CE labeled. 240, 512, 600, 1024, 1200, 2048 pulses/revolution		OUTLINE PAGE 4.58 		Heavy Industrial Industrial Applications with temperatures between 40°C and +80°C.
Dynapar H56 Rotopulser (Replaces the 62P) 56C face mounted tach (mounts same as BC series tachs). Heavy mill duty enclosure, 5-26 VDC input, push-pull and differential line driver, 5-26 VDC, single output, pluggable screw terminals (Industrial connectors) mating connector(s) included. 240, 512, 600, 1024, 1200, 2048 pulses/revolution, single output 240, 512, 600, 1024, 1200, 2048 pulses/revolution, dual output		OUTLINE PAGE 4.59 		Heavy Mill Duty Industrial Applications with temperatures between -40°C and +80°C NEMA 4/IP66 enclosure. Suitable for severe duty in paper, steel and lumber mills.
Notes: The HA625, H56 and X25 require a Tach mounting kit. (Tach mounting kit consists of Tach adapter, coupling and stub shaft). The H56 can also be foot mounted. The HA625, H56 and X25 can not be mounted on CD180-CD210 TEFC motors. Use TENV enclosure. (ppr) pulses per revolution, required at time of order				

Accessories and Modifications

CD180AT through CD6900

Accessories and Modifications

ITEM	DESCRIPTION				
29b Cont'd	MOTOR MOUNTED, DIRECT CONNECTED TACHOMETERS		MOTOR FRAME SIZE		
			CDL182AT- CD5010AY	CD6000- CD6900	
	MODEL NUMBER AND DESCRIPTION		List Price Addition		Environmental Rating
	Dynapar HS35R Sealed Hollow Shaft Hollow shaft encoder is designed for easy installation onto the motor, the unit sealed as well as equipped with an unbreakable disk that meets the demands of the most severe shake and vibration, the unit is electrically and thermally isolated, shaft seals at both ends, dust cover included. 5-26 VDC input, push-pull and differential line driver, 5-26 VDC output. 240, 512, 600, 1024, 1200, 2048 pulses/revolution, single output		OUTLINE PAGE 4.58		Industrial Industrial Applications with temperatures between -40°C and +70°C
			\$1200	\$1325	
Dynapar X25 Explosionproof Flange mounted tach, UL listed for Class 1, Division 1 & 2, Groups C, D, E, F, G locations, 5-26 VDC input, push-pull and differential line driver, 5-26 VDC output, single output 1/2-14 NPTF conduit entry. Heavy industrial enclosure. 240, 512, 600, 1024, 1200, 2048 pulses/revolution		OUTLINE PAGE 4.58		Explosionproof Industrial Applications with temperatures between 0°C and +70°C	
		\$3360	\$3864		
Notes: The HA625, H56 and X25 require a Tach mounting kit. (Tach mounting kit consists of Tach adapter, coupling and stub shaft). The H56 can also be foot mounted. The HA625, H56 and X25 can not be mounted on CD180-CD210 TEFC motors. Use TENV enclosure. (ppr) pulses per revolution, required at time of order					
29c	CUSTOMER SUPPLIED TACHOMETERS Customer-supplied tachometers will not be tested. Drawings and parts list of customer-supplied tachometers must be received at the time of order. Both the tachometer and shipping papers must be tagged with the Wolong order and item number. Refer to customer-supplied material section (page 3.12, Item 14) for additional information.				
MOTOR MOUNTED, DIRECT CONNECTED TACHOMETERS		MOTOR FRAME SIZE			
		CDL182AT- CD5010AY	CD6000- CD6900		
		List Price Addition			
For mounting only of a customer-supplied Type C-Face tachometer. (This includes coupling, stub shaft, mounting bracket, and assembly of tachometer.)		\$3024	\$3858		
For mounting kit only for customer-mounted Type C-Face tachometer. (This includes coupling, stub shaft, and mounting bracket.) Mounting kit is assembled to the motor.		\$1666	\$2500		
30	TERMINAL BOARD IN CONDUIT BOX Generally, all power, field and other internal accessory terminals will be located on a terminal board in the conduit box. On some higher current machines, the field and other internal accessory terminals will be located on a terminal board, but the power leads will be fixed and supported separately (all within the conduit box). On machines rated 2,000 amps or more, the field and other internal accessory terminals will be located on a terminal board and the power leads will be fixed and supported separately as standard (all within the conduit box.)				
List Price Addition					
Motor Frame Size		Shunt Wound		Stabilized Shunt or Compound Wound	
CD218AT-CD5010AY		\$1200		\$1500	
CD6000-CD6900		No Price Addition		Not Available	
Note: Not available for explosionproof motors.					

Accessories and Modifications

CD180AT through CD6900

Accessories and Modifications

ITEM	DESCRIPTION																																																																	
31	TESTS AND CURVES																																																																	
	AVAILABLE FOR CDL180AT-CD5010AY FRAME AND CD6000-CD6900 FRAME MOTORS																																																																	
	<table border="1" style="width: 100%;"> <thead> <tr> <th>Routine Test</th> <th>Motor</th> <th>Generator</th> </tr> </thead> <tbody> <tr><td>Neutral Check</td><td>YES</td><td>YES</td></tr> <tr><td>Winding Resistance</td><td>YES</td><td>YES</td></tr> <tr><td>High Potential</td><td>YES</td><td>YES</td></tr> <tr><td>Commutation Check</td><td>YES</td><td>YES</td></tr> <tr><td>Voltage Regulation</td><td>NO</td><td>YES</td></tr> <tr><td>Vibration Test</td><td>YES</td><td>YES</td></tr> <tr><td>Saturation Curve</td><td>NO</td><td>YES</td></tr> <tr><td>No Load Speed</td><td>YES</td><td>NO</td></tr> <tr><td>Running Full Load</td><td>YES</td><td>YES</td></tr> </tbody> </table>			Routine Test	Motor	Generator	Neutral Check	YES	YES	Winding Resistance	YES	YES	High Potential	YES	YES	Commutation Check	YES	YES	Voltage Regulation	NO	YES	Vibration Test	YES	YES	Saturation Curve	NO	YES	No Load Speed	YES	NO	Running Full Load	YES	YES	<table border="1" style="width: 100%;"> <thead> <tr> <th>Complete Test</th> <th>Motor</th> <th>Generator</th> </tr> </thead> <tbody> <tr><td>Neutral Check</td><td>YES</td><td>YES</td></tr> <tr><td>Full Load Heat Run</td><td>YES</td><td>YES</td></tr> <tr><td>Winding Resistance</td><td>YES</td><td>YES</td></tr> <tr><td>High Potential</td><td>YES</td><td>YES</td></tr> <tr><td>Commutation Adjustment</td><td>YES</td><td>YES</td></tr> <tr><td>Saturation Curve</td><td>NO</td><td>YES</td></tr> <tr><td>Voltage Regulation</td><td>NO</td><td>YES</td></tr> <tr><td>Running Full Load</td><td>YES</td><td>YES</td></tr> <tr><td>Speed Regulation (base speed and top weak field speed)</td><td>YES</td><td>NO</td></tr> </tbody> </table>			Complete Test	Motor	Generator	Neutral Check	YES	YES	Full Load Heat Run	YES	YES	Winding Resistance	YES	YES	High Potential	YES	YES	Commutation Adjustment	YES	YES	Saturation Curve	NO	YES	Voltage Regulation	NO	YES	Running Full Load	YES	YES	Speed Regulation (base speed and top weak field speed)	YES	NO
	Routine Test	Motor	Generator																																																															
	Neutral Check	YES	YES																																																															
	Winding Resistance	YES	YES																																																															
	High Potential	YES	YES																																																															
	Commutation Check	YES	YES																																																															
	Voltage Regulation	NO	YES																																																															
	Vibration Test	YES	YES																																																															
Saturation Curve	NO	YES																																																																
No Load Speed	YES	NO																																																																
Running Full Load	YES	YES																																																																
Complete Test	Motor	Generator																																																																
Neutral Check	YES	YES																																																																
Full Load Heat Run	YES	YES																																																																
Winding Resistance	YES	YES																																																																
High Potential	YES	YES																																																																
Commutation Adjustment	YES	YES																																																																
Saturation Curve	NO	YES																																																																
Voltage Regulation	NO	YES																																																																
Running Full Load	YES	YES																																																																
Speed Regulation (base speed and top weak field speed)	YES	NO																																																																
CHARGES																																																																		
<table border="1" style="width: 100%;"> <thead> <tr> <th>Tests</th> <th>Net Price Addition</th> </tr> </thead> <tbody> <tr> <td>A. Certified Test Report - Electrically duplicate machine previously tested</td> <td>\$300 per motor</td> </tr> <tr> <td>B. Unwitnessed Routine Test - 5 copies of certified test reports</td> <td>\$300 per motor</td> </tr> <tr> <td>C. Witnessed Routine Tests - 5 copies of certified test reports</td> <td>\$1800 per motor; Add 2 weeks lead time</td> </tr> <tr> <td>D. Unwitnessed Complete Test - 5 copies of certified test reports</td> <td>\$4250 per motor; Add 2 weeks lead time</td> </tr> <tr> <td>E. Witnessed Complete Test - 5 copies of certified test reports</td> <td>\$5500 per motor; Add 3 weeks lead time</td> </tr> </tbody> </table>					Tests	Net Price Addition	A. Certified Test Report - Electrically duplicate machine previously tested	\$300 per motor	B. Unwitnessed Routine Test - 5 copies of certified test reports	\$300 per motor	C. Witnessed Routine Tests - 5 copies of certified test reports	\$1800 per motor; Add 2 weeks lead time	D. Unwitnessed Complete Test - 5 copies of certified test reports	\$4250 per motor; Add 2 weeks lead time	E. Witnessed Complete Test - 5 copies of certified test reports	\$5500 per motor; Add 3 weeks lead time																																																		
Tests	Net Price Addition																																																																	
A. Certified Test Report - Electrically duplicate machine previously tested	\$300 per motor																																																																	
B. Unwitnessed Routine Test - 5 copies of certified test reports	\$300 per motor																																																																	
C. Witnessed Routine Tests - 5 copies of certified test reports	\$1800 per motor; Add 2 weeks lead time																																																																	
D. Unwitnessed Complete Test - 5 copies of certified test reports	\$4250 per motor; Add 2 weeks lead time																																																																	
E. Witnessed Complete Test - 5 copies of certified test reports	\$5500 per motor; Add 3 weeks lead time																																																																	
<table border="1" style="width: 100%;"> <thead> <tr> <th>Curves</th> <th>Net Price Addition</th> </tr> </thead> <tbody> <tr> <td>A. Speed and Torque vs Load Current Curve</td> <td>\$300</td> </tr> <tr> <td>B. HP and Efficiency vs Load Current Curve</td> <td>\$300</td> </tr> </tbody> </table>					Curves	Net Price Addition	A. Speed and Torque vs Load Current Curve	\$300	B. HP and Efficiency vs Load Current Curve	\$300																																																								
Curves	Net Price Addition																																																																	
A. Speed and Torque vs Load Current Curve	\$300																																																																	
B. HP and Efficiency vs Load Current Curve	\$300																																																																	
31a	CERTIFICATES																																																																	
	<table border="1" style="width: 100%;"> <tbody> <tr> <td>Certificate of Compliance</td> <td>\$150 Net Price Addition</td> </tr> </tbody> </table>				Certificate of Compliance	\$150 Net Price Addition																																																												
Certificate of Compliance	\$150 Net Price Addition																																																																	

Accessories and Modifications

CD180AT through CD6900

ITEM	DESCRIPTION				
32	TEMPERATURE DETECTORS				
	A bimetallic temperature-sensing device is mounted on the commutating coil. The device is available with normally open or normally closed contactors. Specify whether normally open or normally closed contacts are required. (Included as standard on TEUC motors). Thermostats are typically normally closed and the opening temperature is between 120° C to 150°C. Thermostats with special temperature rating are non-standard. Refer to Wolong when required.				
	Thermostat ratings for DPGF and TE motors (standard on TEAAC, TEWAC and explosionproof motors)	Maximum Current Ratings (Normally open or normally closed contacts)			
		Load	125V AC	250V AC	600V AC
		Resistive	5 Amps	2.5 Amps	1 Amp
Inductive*	3 Amps	1.5 Amps	0.5 Amp (Do not use above 600V AC)	5 Amps 1.5 Amps (Do not use above 30V DC)	
* Suitable for pilot duty only (relay coils)					
For the following types of temperature detectors mounted in the locations indicated, see below for pricing. Price does <u>not</u> include electronic sensor module.					
TEMPERATURE DETECTORS		LOCATION			
		Bearing	Commutator Field or Shunt Field		
List Price Addition					
a. Thermostats		Not Available	\$310		
b. Thermistors (PTC Type)		Not Available	\$450		
c. Resistance Temperature Detectors (RTD)					
Copper - 10 Ohm		\$2266	\$900		
Platinum - 100 Ohm		\$4532	\$1800		
Nickel - 120 Ohm		\$2266	\$900		
d. Thermocouples (Type J)		\$2266	Not Available		
33	VERTICAL MOUNTING (FOOTED)				
	The following applies to vertically-operated foot- or flange-mounted, standard ball bearing, motors where no external thrust is reflected back to the motor shaft. Refer to Wolong for external thrust limitations. For vertical brake applications, refer to Modification Item 8a. Note: For crane motors, refer to page 3.11, Item 13.				
	All drip-proof and splash-proof motors which are mounted vertically require non-standard covers (the louvers are rotated to provide protection in the vertical position). Totally enclosed motors require no modifications to the covers. Frames CD180AT-CD320AT do not require internal modification for vertical mounting. Thus, a standard motor in these frame sizes is suitable for vertical mounting.				
	Frames CD360AT-CD6900 require internal modification for vertical mounting. Thus, a standard motor in these frame sizes is not suitable for vertical mounting. The CD365AT-CD5010AY frames require shaft seals for vertical mounting with the shaft down. The CD365AT-CD5010AY frames mounted shaft up require additional modifications to the bearings and shaft. Refer to Wolong for applications involving vertical mounting of CD6000-CD6900 frames.				
	Enclosure		List Price Addition		
		CD180AT-CD320AT	CD365AT-CD5010AY		
Vertical Shaft Down	DP	Add 2%	Add 2% + \$596		
	TE	No Price Addition*	Add 2% + \$596*		
Vertical Shaft Up	DP	Add 2% ③	Add 2% + \$1050		
	TE	No Price Addition	Add 2% + \$1050		
Refer to Wolong					
Notes: DP Dripproof TE Totally Enclosed * If TEFC waterproof, contact Wolong ③ For CD180AT, will not meet NEMA definition for DPGF, the motor is considered "fully guarded". (Refer to page 3.16, Item 17 for C-Face and D-Flange pricing.)					

Accessories and Modifications

CD180AT through CD6900

Accessories and Modifications

ITEM	DESCRIPTION		
34	VOLTAGES		
34a	Armature, Non-Standard		
	Provides for special armature voltages, with same speed range and operating characteristics as standard ratings. Frames may be different than standard.		
	VOLTAGES, ARMATURE (NON-STANDARD)		
	Voltage	HP	Base Speed RPM
	120	1-3	1150-3500
	105-130	Contact GE	
	550	1-250 300-2000	ALL ALL
	600	7 1/2-4500	ALL
	700	500-1000 1250-4500	300-1150 ALL
	750	300-1000 1250-4500	ALL ALL
			List Price Addition
			No price addition
			No price addition Add 3%
			No price addition
			Add 6%
			No price addition
			Add 6%
			Add 3%
34b	Field, Standard		
	The following field voltages are standard. Voltages listed are nominal values. For more exact values, refer to Wolong .		
	Standard Armature Voltages	Standard Field Voltages (Frames CD5010AY and Below)	Standard Field Voltages (CD6000-CD6900 frames)
	180	100, 200	—
	240, 500, 700	120, 150, 240, 300	120, 150, 200, 240, 300
34c	Field, Non-Standard		
	Non-standard field voltages can be obtained by using the standard fields and adding a series resistance. For non-standard field voltages and pricing, refer to Wolong .		
35	WARRANTY EXTENSION		
	The standard warranty for Kinamatic motors is 24 months from title transfer to third party, and 30 months from shipment by seller, whichever occurs first. The CD6000 standard warranty is 12 months from title transfer to 3rd party, and 18 months from shipment by seller, whichever occurs first. Extended warranties are available as follows:		
35a	Kinamatic Warranty Extension		
	From Title Transfer to 3rd Person	From Shipment by Seller	Price Addition
	36 months	42 months	Add 3% of Motor NET Price
35b	CD6000 Series Warranty Extension		
	From Title Transfer to 3rd Person	From Shipment by Seller	Price Addition
	24 months	30 months	Add 3% of Motor NET Price

Note: For voltages not listed in the table, refer to **Wolong** with application requirements, including type of power supply, speed range by field control, and armature-voltage control.

Accessories and Modifications

CD180AT through CD6900

ITEM	DESCRIPTION												
36	<p>WINDINGS, STABILIZED SHUNT, COMPOUND OR SERIES</p> <p>Stabilized shunt, compound, or series windings are not available on frames CD329AT, CD6700, CD6800 and CD6900. These frames are only available with shunt wound fields. Also not available on some CD328AT frames. Refer to Wolong for all design verification.</p> <p>Standard motors are shunt wound. Where speed regulation greater than that provided by shunt wound is required, a compound or stabilized shunt wound motor may be specified.</p> <p>Standard compound wound motors will have approximately 15-25% speed regulation at rated speed. For other degrees of compounding, refer to Wolong.</p> <p>CAUTION:</p> <p>Compound wound motors are generally not suited to applications requiring speed control by field weakening. In no case should the field be weakened more than enough to obtain 125% of rated speed. When use with field weakening is intended, the order must specify the speed range. The nameplate will show maximum allowable speed.</p> <p>WARNING:</p> <p>Series motor excitation is entirely dependent on load. The application of series motors should be avoided where the load may drop below 25% rated torque or where the load is not solidly coupled, since the motor may over-speed. Standard base speeds of series wound motors are different than shunt wound motors. Refer to Wolong for exact speeds.</p>												
MOTOR LIST PRICE													
DESCRIPTION	Up to \$2500	\$2501 to \$3592	\$3593 to \$5578	\$5579 to \$9748	\$9749 to \$13218	\$13219 to \$23922	\$23923 to \$42136	\$42137 to \$61750	\$61751 to \$98628	\$98629 to \$157704	\$157704 to \$252288	\$252289 to \$403650	\$403651 and up
List Price Addition													
For Stabilized Shunt, Compound or Series Windings*	\$244	\$244	\$330	\$424	\$516	\$690	\$892	\$1540	\$2430	\$4860	\$9720	\$19440	Not Available
* For frames where this is not available, see above.													

Accessories and Modifications

CD180AT through CD6900

Accessories and Modifications

ITEM	DESCRIPTION					
37	MOD SHOP PRICING					
	Modification	FRAME SIZE				
		List Price Addition				
	CD180AT	CD210AT-CD280AT	CD320AT	CD360AT	CD400AT	CD500AT-CD5010AY
Mod Shop Fee	\$250	\$320	\$650	\$720	\$1200	\$1600
Standard C-Face Endshield (Specify 4.5" or 8/5" for CD180AT)	\$200	\$725	\$1200	\$3000	N.A.	N.A.
Conduit Box:						
Condulet Off Main Conduit Box (for accessory leads)	\$605	\$605	\$605	\$825	\$825	\$825
Waterproof	\$495	\$495	\$495	\$990	\$990	\$990
Covers:						
Transparent* (Lucite or equivalent)	\$300	\$300	\$450	\$450	\$450	\$450
Transparent* (Lexan or equivalent)	\$600	\$600	\$900	\$900	\$900	\$900
Auxiliary or Customer Nameplate	\$60	\$60	\$60	\$60	\$60	\$60
Enclosure Conversions:						
DPFG-BV (Blower, with filter, mounted on comm end only)						
- 230/460 Volt, 60Hz	\$1600	\$2850	\$3150	\$3500	\$4100	\$5250
DPFG (Self-Ventilated - Motor must have internal fan, Contact GE)	\$300	\$300	\$600	\$600	\$600	\$1200
DPFG-SV (Separately Ventilated on comm end only)	\$300	\$300	\$600	\$600	\$600	\$1200
SPFG Splashproof Fully Guarded (add for Blower as required)	\$300	\$300	\$600	\$600	\$600	\$1200
Sliding Base (Horizontal mounting only)	\$300	\$450	\$600	\$1100	\$2000	\$2600
Transition Base (Horizontal mounting only)	\$450	\$900	\$1200	\$2200	\$4000	\$5200
Space Heater (120V AC Standard - Inquire for optional voltages)	\$640	\$640	\$640	\$640	\$640	\$640
Tachometers (Analog)						
Type AN-AC 45 or 90V/1000 RPM	\$1975	\$1975	\$1975	\$1975	\$1975	\$1975
Form Y (PY), DC 50 or 100V/1000 RPM (max speed 2500 RPM)	\$5400	\$5400	\$5400	\$5400	\$5400	\$5400
Type BC						
- BC42, 50 or 100V/1000 RPM	\$8175	\$8175	\$8175	\$8175	\$8175	\$8175
- BC46, 50, 100, or 200V/1000 RPM	\$11000	\$11000	\$11000	\$11000	\$11000	\$11000
Type BC Waterproof or Dustproof						
- BC42, 100V/1000 RPM	\$9025	\$9025	\$9025	\$9025	\$9025	\$9025
- BC46, 100V/1000 RPM	\$11800	\$11800	\$11800	\$11800	\$11800	\$11800
Tachometers (Digital)						
Avtron AV850 SMARTach II (Type AN-DG) (HD)						
- 240, 600, 1024, or 1200 ppr, single output	\$5300	\$5300	\$5300	\$5300	\$5300	\$5300
- 240, 600, 1024, or 1200 ppr, dual output	\$7750	\$7750	\$7750	\$7750	\$7750	\$7750
NorthStar RIM Tach 8500 NexGen						
- 240, 512, 600, 1024, or 1200 ppr, single output	\$4650	\$4650	\$4650	\$4650	\$4650	\$4650
- 240, 512, 600, 1024, or 1200 ppr, dual output	\$5750	\$5750	\$5750	\$5750	\$5750	\$5750
Tachometer Mounting Only						
Form Y (PY) Mounting Kit Only Assembled to Motor						
- Includes Coupling, Stub Shaft, Mounting Bracket for PY	\$1850	\$1850	\$1850	\$1850	\$1850	\$1850
Type C-Face Tachometer Mounting Kit Only Assembled to Motor						
- Includes Coupling, Stub Shaft, Mounting Bracket	\$1850	\$1850	\$1850	\$1850	\$1850	\$1850
Mounting Customer-supplied C-Face tachometer						
- Includes Coupling, Stub Shaft, Mounting Bracket	\$3325	\$3325	\$3325	\$3325	\$3325	\$3325
Vertical (Frame will be supplied with feet)						

* Not Available on all CD180AT frames or CD210AT TEFC Frames

Accessories and Modifications

CD180AT through CD6900

ITEM	DESCRIPTION																												
37 Cont'd	<p>Pricing Example</p> <table border="0" style="width: 100%; border-collapse: collapse;"> <tr> <td style="width: 15%; border-bottom: 1px solid black;">D450 5CD184TA094B070</td> <td style="width: 30%; border-bottom: 1px solid black;">Motor List</td> <td style="width: 15%; border-bottom: 1px solid black; text-align: right;">\$18,098</td> <td style="width: 40%;"></td> </tr> <tr> <td></td> <td style="border-bottom: 1px solid black;">Mod Shop Fee</td> <td style="border-bottom: 1px solid black; text-align: right;">\$650</td> <td></td> </tr> <tr> <td style="border-bottom: 1px solid black;">Lexan Covers</td> <td></td> <td style="border-bottom: 1px solid black; text-align: right;">\$900</td> <td></td> </tr> <tr> <td style="border-bottom: 1px solid black;">120V Space Heater</td> <td></td> <td style="border-bottom: 1px solid black; text-align: right;">\$640</td> <td></td> </tr> <tr> <td></td> <td style="border-bottom: 1px solid black;">Mod Motor List</td> <td style="border-bottom: 1px solid black; text-align: right;">\$21,050</td> <td></td> </tr> <tr> <td></td> <td style="border-bottom: 1px solid black;">GO-2A Multiplier</td> <td style="border-bottom: 1px solid black; text-align: right;">x 0.5</td> <td></td> </tr> <tr> <td></td> <td style="border-bottom: 1px solid black;">Mod Motor Net</td> <td style="border-bottom: 1px solid black; text-align: right;">\$10,525</td> <td></td> </tr> </table> <p>Additional Information:</p> <ol style="list-style-type: none"> 1. MOTOR - List price from GE Standard Products Catalog or Elitenet 2. MOD SHOP FEE - List price per the appropriate frame size from the top row of this price list 3. MODIFICATION LIST PRICE - Add price(s) for all modifications from the price list 4. MULTIPLIER SYMBOL - Use your appropriate multiplier based on multiplier symbol for stock motor 5. MULTIPLIER TIMES TOTAL LIST = NET PRICE <p>If you have any questions, or require a modification that is not listed, please contact your Wolong Sales Representative.</p> <p>Pricing subject to change without notice. Verify pricing and lead time with your Wolong Sales Representative at time of order.</p>	D450 5CD184TA094B070	Motor List	\$18,098			Mod Shop Fee	\$650		Lexan Covers		\$900		120V Space Heater		\$640			Mod Motor List	\$21,050			GO-2A Multiplier	x 0.5			Mod Motor Net	\$10,525	
D450 5CD184TA094B070	Motor List	\$18,098																											
	Mod Shop Fee	\$650																											
Lexan Covers		\$900																											
120V Space Heater		\$640																											
	Mod Motor List	\$21,050																											
	GO-2A Multiplier	x 0.5																											
	Mod Motor Net	\$10,525																											

Accessories and Modifications

Outline Dimensions

Index

Frame Size	Outline	Page	Frame Size	Outline	Page
L182AT to 189AT.	DPFG, TENV	4.2	6000 to 6200	TEWAC	4.40
L182ACY to 189ACY	DPFG, TENV	4.3	6700 to 6900	TEWAC	4.41
L182ATC to 189ATC.	DPFG, TENV	4.4	6050 to 6066	Air Openings.	4.42
L182ATD to 189ATD	DPFG, TENV	4.5	6154 to 6177	Air Openings.	4.43
L182AT to 189AT.	TEFC.	4.6	6259 to 6280	Air Openings.	4.44
L182ACY to 189ACY	TEFC.	4.7	6766 to 6785	Air Openings.	4.45
L182ATC to 189ATC.	TEFC.	4.8	6873 to 6896	Air Openings.	4.46
L182ATD to 189ATD	TEFC.	4.9	6977 to 6999	Air Openings.	4.47
218AT to 329AT	DPFG, TENV	4.10	180AT to 5010AY	Accessory Mountings	4.48
218ATC to 329ATC	DPFG, TENV	4.11	6000 to 6900	Accessory Mountings	4.49
218ATD to 329ATD	DPFG, TENV	4.12	180AT to 500AT	Accessory Couplings.	4.50
218AT to 2110AT	TEFC.	4.13	and 6000 to 6900		
258AT to 328AT	TEFC.	4.14	180AT to 500AT	Accessory Adapters	4.51
365AT to 5010AY	DPFG, TENV	4.15	and 6000 to 6900		
365ATD to L508ATD	DPFG, TENV	4.16	180AT to 6900.	Speed Limit Device.	4.52
365AT to 5010AY	Conduit Box	4.17	180AT to 6900.	Avtron Tachometer.	4.53
365AT to L409AT	TEFC.	4.18	180AT to 6900.	Avtron Tachometer.	4.54
188AT to 409AT	Explosionproof	4.19	180AT to 6900.	Type AN Tachometer	4.55
188ATC to 189ATC	Explosionproof	4.20	CD180AT to CD6900	NorthStar Tachometer	4.56
366AT to L508AT	TEAAC.	4.21	CD180 to CD6900.	NorthStar Tachometer	4.57
5010AY	TEAAC.	4.22	CD180 to CD6900.	Dynapar Encoder.	4.58
327AT to L508AT	TEAO	4.23	180AT to 6900.	Dynapar Rotopulser	4.59
210AT to 5010AY	Air Openings.	4.24	180AT to 6900.	Excellon® Type BC	4.60
180AT to 280AT	Blower Ventilated.	4.25		Tachometer	
320AT	Blower Ventilated.	4.26	180AT to 6900.	Excellon Form Y.	4.61
360AT to 400AT	Blower Ventilated.	4.27		Tachometer	
500AT	Blower Ventilated.	4.28	180AT to 500AT	Sliding Base	4.62
6050 to 6066	DPFG-SV, ESV	4.29	CD210AT to CD500AT	Soleplates	4.63
6154 to 6177	DPFG-SV, ESV	4.30	CD6050 to CD6280.	Soleplates	4.64
6259 to 6280	DPFG-SV, ESV	4.31	CD6766 to CD6999.	Soleplates	4.65
6766 to 6785	DPFG-SV, ESV	4.32		NEMA Mounting Configurations.	4.66
6873 to 6896	DPFG-SV, ESV	4.33			
6977 to 6999	DPFG-SV, ESV	4.34			
6000 to 6900	Blower Ventilated, No Filter	4.35			
6000 to 6900	Blower Ventilated, With Filter	4.36			
6000 to 6900	Splashproof, Blower Ventilated	4.37			
6000 to 6200	TEAAC.	4.38			
6700 to 6900	TEAAC.	4.39			

DIMENSIONS - For ESTIMATING ONLY unless endorsed for construction

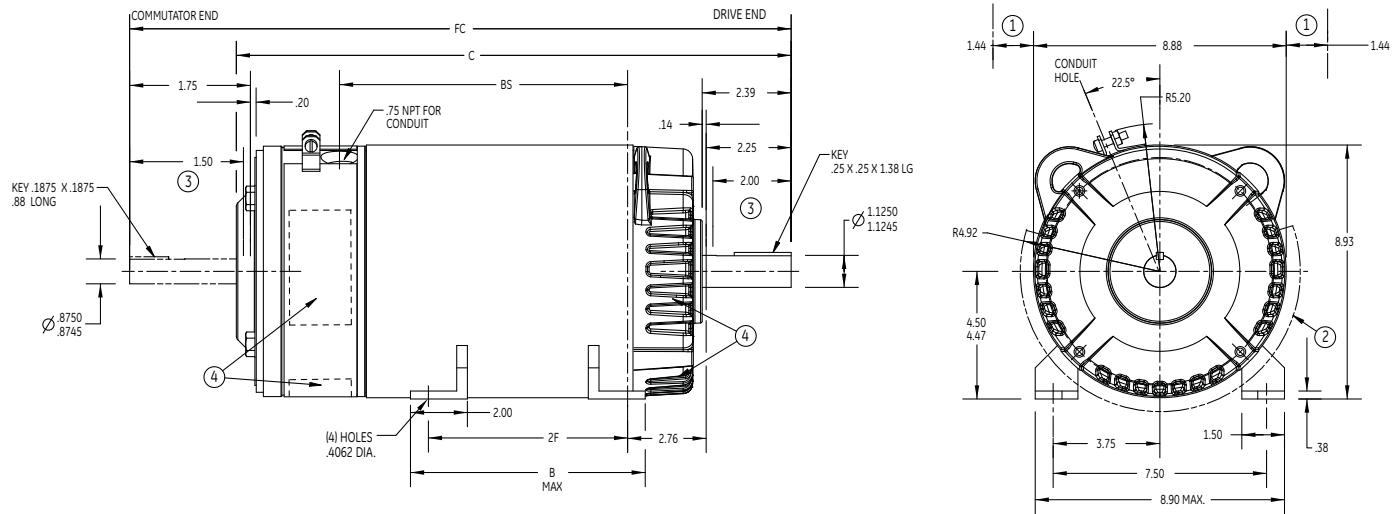

- ① Splashproof fully guarded machines will have additional covers, increasing the overall width at the commutator end and drive end side air openings.
- ② Dripproof, fully guarded vertical drive end shaft down machines will have additional covers, increasing the overall width and exceeding bottom of mounting feet at the commutator end openings.
- ③ Represents minimum length of shaft available for hubs.
- ④ Air openings for dripproof fully guarded. Totally enclosed machines will not have openings.

Commutator end shaft extension is furnished only when specifically ordered.

Shaft runout shall not exceed 0.002 inch total indicator reading.

The standard single shaft machine has the commutator end bearing bracket and shaft extension prepared to accept accessories. For additional information, see page 4.48.

For blower ventilated, blower can only be mounted on side of motor, because there's no air opening at the top of the motor. The motor leads exit at the top of the motor.

Outline Dimensions

Frame	Approx. Wk ² of Arm. Lb. Ft. ²	B	C	FC	2F	BS	Approx. Net Wt. Lbs.
L182AT	0.28	5.80	15.26	16.51	4.50	6.63	83
186AT	0.45	8.30	16.76	18.01	7.00	8.13	105
L186AT	0.67	8.30	18.76	20.01	7.00	10.13	128
189AT	0.77	11.56	20.76	22.01	10.00	12.13	162

Frames L182ACY to 189ACY

4.5" Type C-Face Mounting with Feet

Dripproof Fully Guarded and
Totally Enclosed Nonventilated

Type CD

DIMENSIONS - For ESTIMATING ONLY unless endorsed for construction

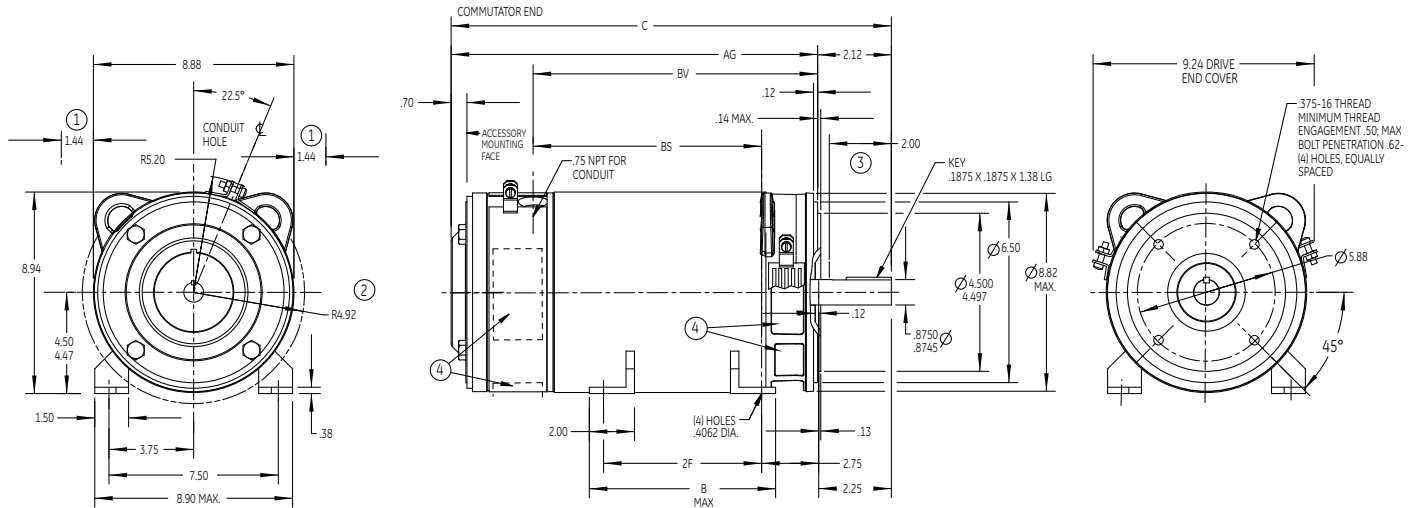

- ① Splashproof fully guarded machines will have additional covers, increasing the overall width at the commutator end and drive end side air openings.
- ② Dripproof, fully guarded vertical drive end shaft down machines will have additional covers, increasing the overall width and exceeding bottom of mounting feet at the commutator end openings.
- ③ Represents minimum length of shaft available for hubs.
- ④ Air openings for dripproof fully guarded. Totally enclosed machines will not have openings.

Mounting face will be square and rabbet diameter concentric with shaft within .004 inch total indicator reading.

Shaft runout not to exceed .002 inch total indicator reading.

The standard single shaft machine has the commutator end bearing bracket and shaft extension prepared to accept accessories. For additional information, see page 4.48.

Frame	Approx. Wk ² of Arm. Lb. Ft. ²	B	C	2F	AG	BS	BV	Approx. Net Wt. Lbs.
L182ACY	0.28	5.80	15.26	4.50	13.14	6.63	9.51	80
186ACY	0.45	8.30	16.76	7.00	14.64	8.13	11.01	102
L186ACY	0.67	8.30	18.76	7.00	16.64	10.13	13.01	128
189ACY	0.77	11.56	20.76	10.00	18.64	12.13	15.01	162

Outline Dimensions

Frames L182ATC to 189ATC

8.5" Type C-Face Mounting with Feet

Dripproof Fully Guarded and
Totally Enclosed Nonventilated

Type CD

DIMENSIONS - For ESTIMATING ONLY unless endorsed for construction

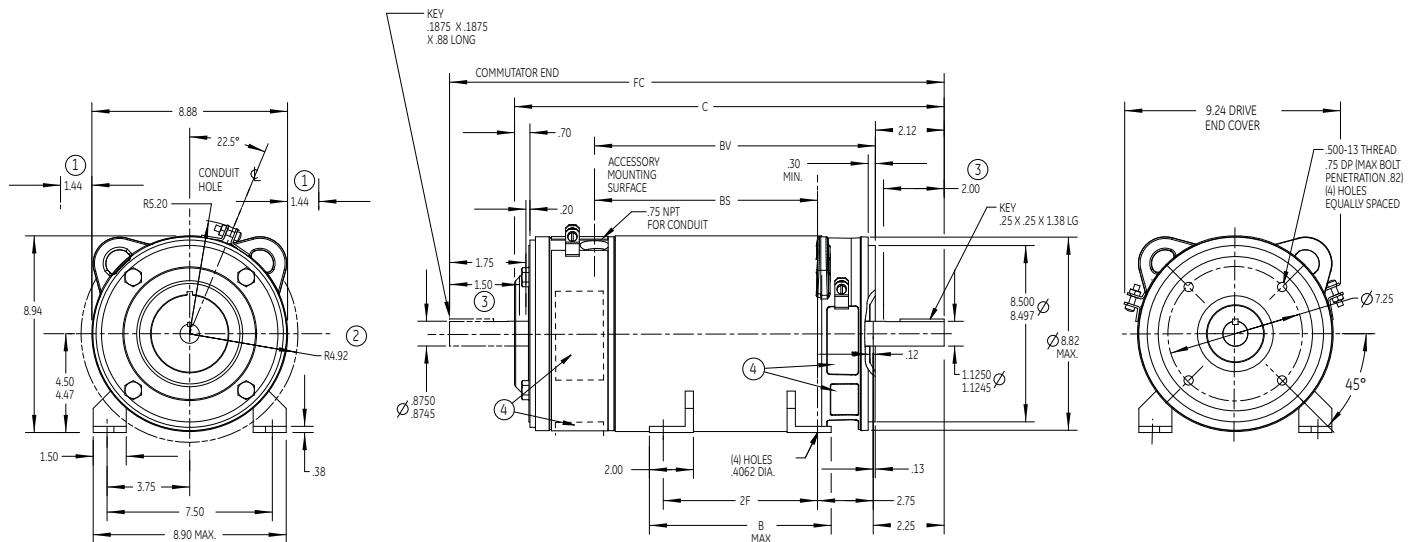

- ① Splashproof fully guarded machines will have additional covers, increasing the overall width at the commutator end and drive end side air openings.
- ② Dripproof, fully guarded vertical drive end shaft down machines will have additional covers, increasing the overall width and exceeding bottom of mounting feet at the commutator end openings.
- ③ Represents minimum length of shaft available for hubs.
- ④ Air openings for dripproof fully guarded. Totally enclosed machines will not have openings.

Mounting face will be square and rabbet diameter concentric with shaft within .004 inch total indicator reading.
 Shaft runout not to exceed .002 inch total indicator reading.
 Commutator end shaft extension is furnished only when specifically ordered.
 The standard single shaft machine has the commutator end bearing bracket and shaft extension prepared to accept accessories. For additional information, see page 4.48.

Outline Dimensions

Frame	Approx. Wk ² of Arm. Lb. Ft. ²	B	C	FC	2F	BS	BV	Approx. Net Wt. Lbs.
L182ATC	0.28	5.80	15.26	16.51	4.50	6.63	9.51	80
186ATC	0.45	8.30	16.76	18.01	7.00	8.13	11.01	102
L186ATC	0.67	8.30	18.76	20.01	7.00	10.13	13.01	128
189ATC	0.77	11.56	20.76	22.01	10.00	12.13	15.01	162

From 36C69710CA

Frames L182ATD to 189ATD

Type D-Flange Mounting with Feet

Dripproof Fully Guarded and
Totally Enclosed Nonventilated

Type CD

DIMENSIONS - For ESTIMATING ONLY unless endorsed for construction

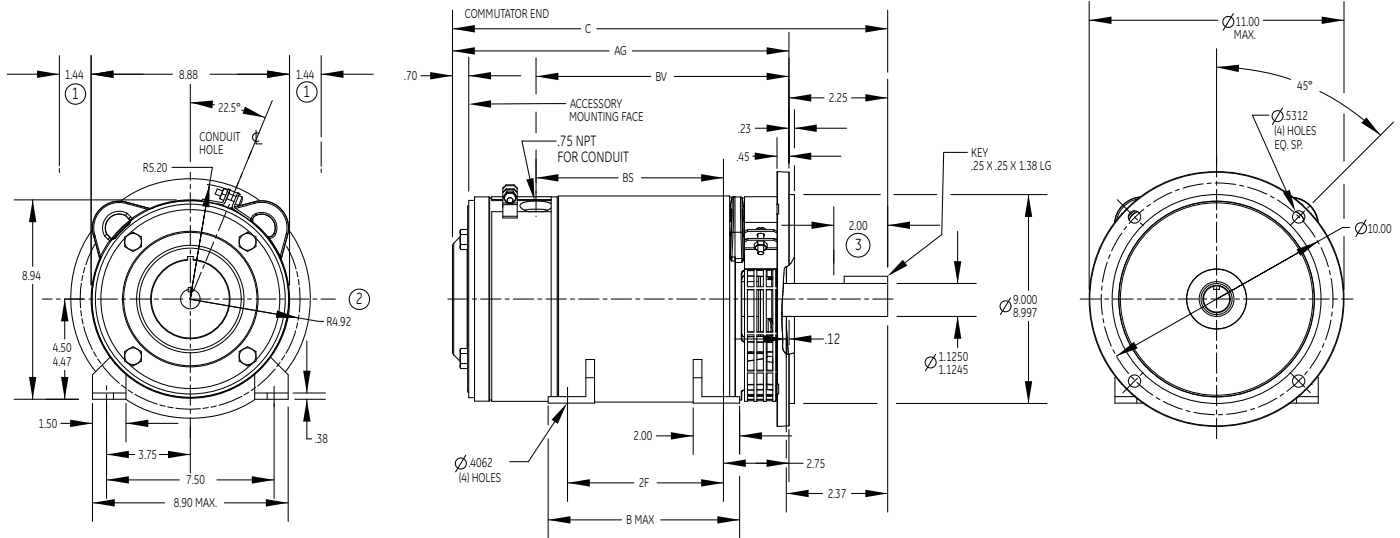

- ① Splashproof fully guarded machines will have additional covers, increasing the overall width at the commutator end and drive end side air openings.
- ② Dripproof, fully guarded vertical drive end shaft down machines will have additional covers, increasing the overall width and exceeding bottom of mounting feet at the commutator end openings.
- ③ Represents minimum length of shaft available for hubs.

Mounting face will be square and rabbet diameter concentric with shaft within .004 inch total indicator reading.

Shaft runout not to exceed .002 inch total indicator reading.

The standard single shaft machine has the commutator end bearing bracket and shaft extension prepared to accept accessories. For additional information, see page 4.48.

Frame	Approx. Wk ² of Arm. Lb. Ft. ²	B	C	2F	AG	BS	BV	Approx. Net Wt. Lbs.
L182ATD	0.28	5.80	15.26	4.50	13.01	6.63	9.38	82
186ATD	0.45	8.30	16.76	7.00	14.51	8.13	10.88	104
L186ATD	0.67	8.30	18.76	7.00	16.51	10.13	12.88	130
189ATD	0.77	11.56	20.76	10.00	18.51	12.13	14.88	164

Outline Dimensions

DIMENSIONS - For ESTIMATING ONLY unless endorsed for construction

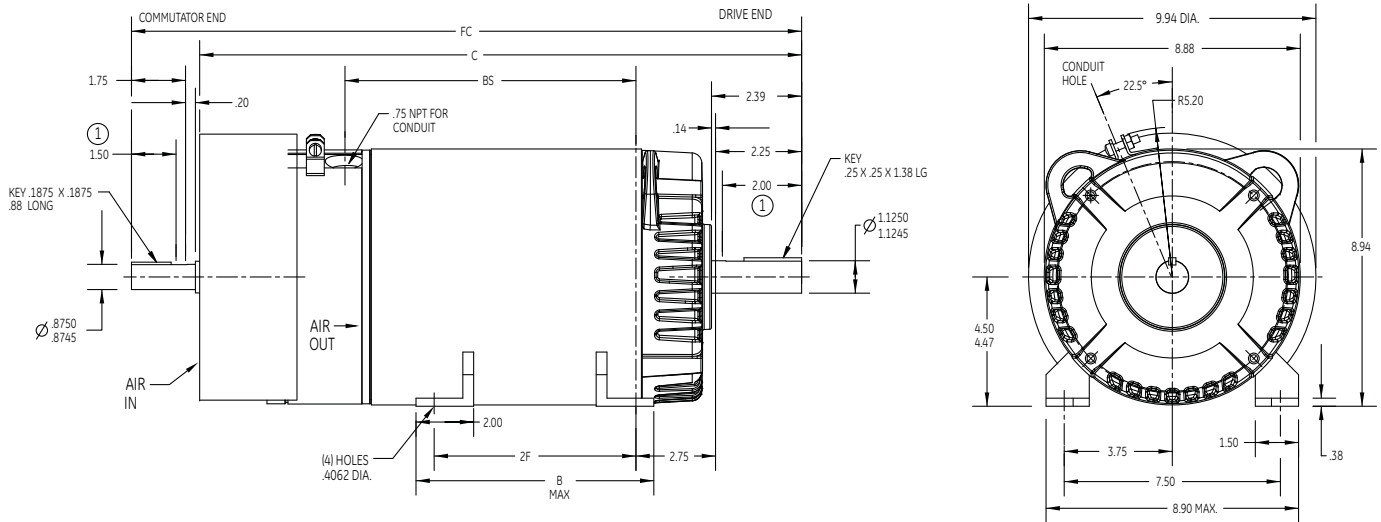

① Represents minimum length of shaft available for hubs.
For mounting position, see enclosure and mounting assembly.

Shaft runout shall not exceed .002 inch total indicator reading.
Commutator end shaft extension is furnished only when specifically ordered.

Outline Dimensions

Frame	Approx. Wk ² of Arm. Lb. Ft. ²	B	C	FC	2F	BS	Approx. Net Wt. Lbs.
182AT	0.28	5.80	17.45	19.47	4.50	6.63	83
186AT	0.45	8.30	18.95	20.97	7.00	8.13	105
L186AT	0.67	8.30	20.95	22.97	7.00	10.13	128
189AT	0.77	11.56	22.95	24.97	10.00	12.13	165

Frames L182ACY to 189ACY

4.5" Type C-Face Mounting with Feet

Totally Enclosed
Fan Cooled

Type CD

DIMENSIONS - For ESTIMATING ONLY unless endorsed for construction

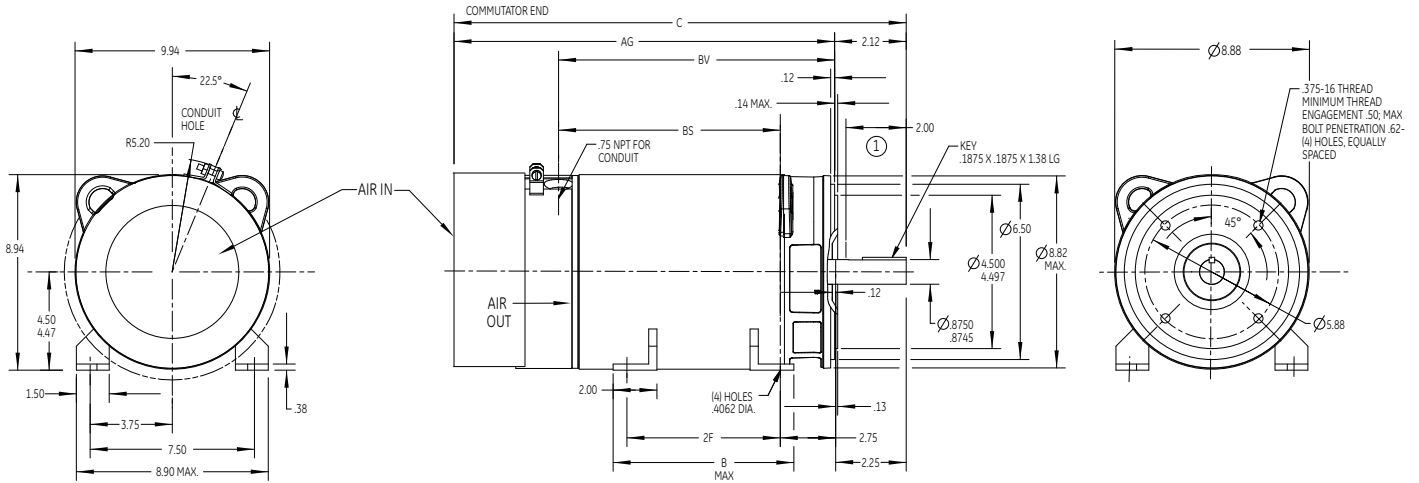

① Represents minimum length of shaft available for hubs.
For mounting position, see enclosure and mounting assembly.

Mounting face will be square and rabbet diameter concentric with shaft within .004 inch total indicator reading.

Shaft runout shall not exceed .002 inch total indicator reading.

Frame	Approx. Wk ² of Arm. Lb. Ft. ²	B	C	2F	AG	BS	BV	Approx. Net Wt. Lbs.
L182ACY	0.28	5.80	17.45	4.50	15.33	6.63	9.51	83
L186ACY	0.45	8.30	18.95	7.00	16.83	8.13	11.01	105
L186ACY	0.67	8.30	20.95	7.00	18.83	10.13	13.01	133
189ACY	0.77	11.56	22.95	10.00	20.83	12.13	15.01	165

Outline Dimensions

From 36B467421TA

Frames L182ATC to 189ATC

8.5" Type C-Face Mounting with Feet

Totally Enclosed
Fan Cooled

Type CD

DIMENSIONS - For ESTIMATING ONLY unless endorsed for construction

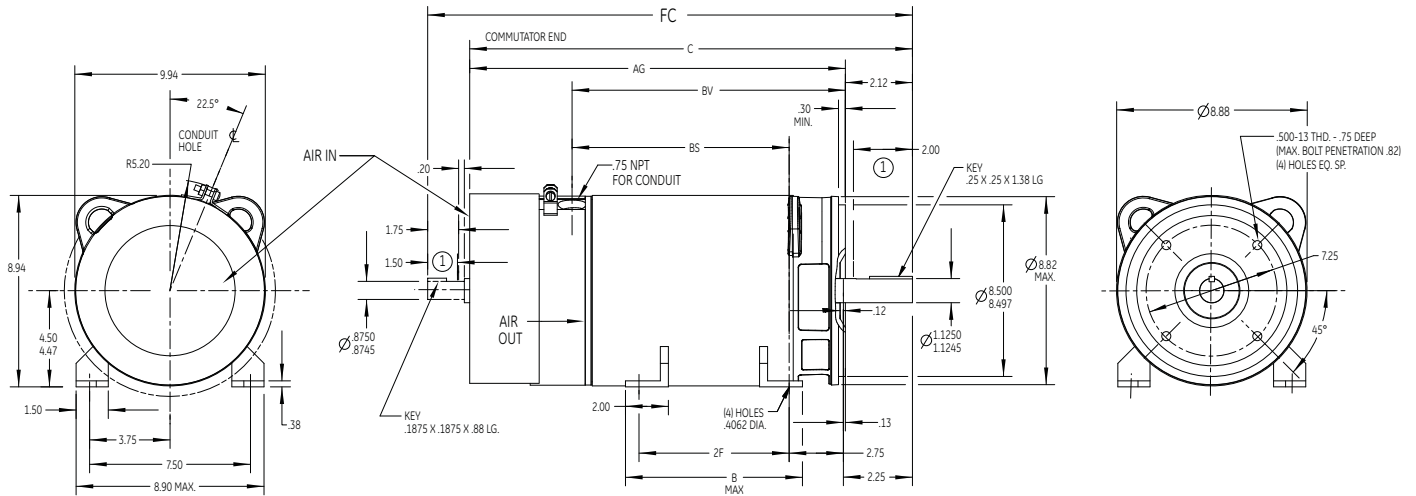

① Represents minimum length of shaft available for hubs.
For mounting position, see enclosure and mounting assembly.
Mounting face will be square and rabbet diameter concentric with shaft within .004 inch total indicator reading.

Shaft runout shall not exceed .002 inch total indicator reading.
Commutator end shaft extension is furnished only when specifically ordered.

Outline Dimensions

Frame	Approx. Wk ² of Arm. Lb. Ft. ²	B	C	FC	2F	AG	BS	BV	Approx. Net Wt. Lbs.
L182ATC	0.28	5.80	17.45	19.47	4.50	15.33	6.63	9.51	83
186ATC	0.45	8.30	18.95	20.97	7.00	16.83	8.13	11.01	105
L186ATC	0.67	8.30	20.95	22.97	7.00	18.83	10.13	13.01	133
189ATC	0.77	11.56	22.95	24.97	10.00	20.83	12.13	15.01	165

Frames L182ATD to 189ATD

Type D-Flange Mounting with Feet

Totally Enclosed
Fan Cooled

Type CD

DIMENSIONS - For ESTIMATING ONLY unless endorsed for construction

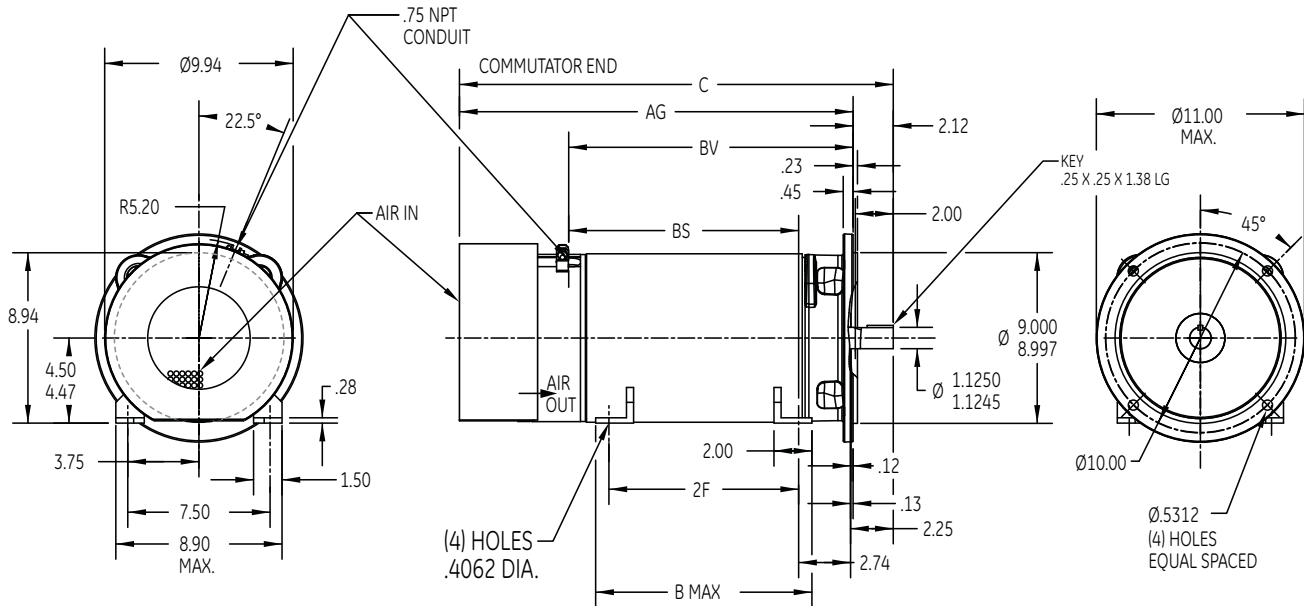

① Represents minimum length of shaft available for hubs.
For mounting position, see enclosure and mounting assembly.

Mounting face will be square and rabbet diameter concentric with shaft within $.004$ inch total indicator reading.

Shaft runout shall not exceed $.002$ inch total indicator reading.

Frame	Approx. Wk ² of Arm. Lb. Ft. ²	B	C	2F	AG	BS	BV	Approx. Net Wt. Lbs.
L182ATD	0.28	5.80	17.45	4.50	15.20	6.63	9.38	85
186ATD	0.45	8.30	18.95	7.00	16.70	8.13	10.88	107
L186ATD	0.67	8.30	20.95	7.00	18.70	10.13	12.88	133
189ATD	0.77	11.56	22.95	10.00	20.70	12.13	14.88	167

Outline Dimensions

From 36B467521FA

DIMENSIONS - For ESTIMATING ONLY unless endorsed for construction

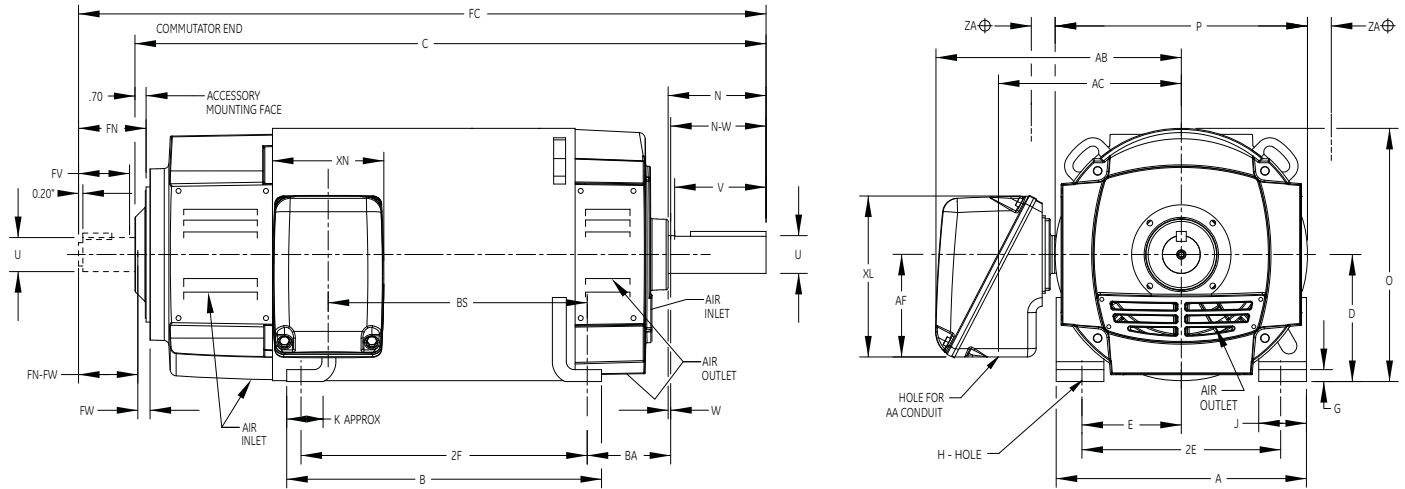

Frame	Approx. Net Wt. in Lb. ⚡	Approx. WK ² of Arm Lb. Ft. ²	DIMENSIONS IN INCHES															
			Drive End			Commutator												
			Key			End Key			A Max.	B Max.	C	‡ D	E	2F	G	H	J	K
218AT	234	1.350	0.3125	0.3125	1.75	0.2500	0.2500	1.00	10.40	11.56	24.22	5.25	4.25	10.0	0.50	0.4062	2.00	2.20
219AT	252	1.490	0.3125	0.3125	1.75	0.2500	0.2500	1.00	10.40	12.56	25.22	5.25	4.25	11.0	0.50	0.4062	2.00	2.20
2110AT	280	1.710	0.3125	0.3125	1.75	0.2500	0.2500	1.00	10.40	14.06	26.72	5.25	4.25	12.5	0.50	0.4062	2.00	2.20
258AT	361	2.910	0.3750	0.3750	2.25	0.3125	0.3125	1.50	12.40	14.06	27.14	6.25	5.00	12.5	0.62	0.5312	2.25	2.00
259AT	403	3.310	0.3750	0.3750	2.25	0.3125	0.3125	1.50	12.40	15.56	28.76	6.25	5.00	14.0	0.62	0.5312	2.25	2.00
287AT	493	4.670	0.5000	0.5000	2.50	0.3750	0.3750	2.00	13.88	14.16	30.98	7.00	5.50	12.5	0.64	0.5312	2.50	2.00
288AT	548	5.360	0.5000	0.5000	2.50	0.3750	0.3750	2.00	13.88	15.66	32.72	7.00	5.50	14.0	0.64	0.5312	2.50	2.00
327AT	691	8.450	0.5000	0.5000	3.00	0.5000	0.5000	2.25	15.88	15.96	33.44	8.00	6.25	14.0	0.50	0.6562	3.00	2.30
328AT	769	9.670	0.5000	0.5000	3.00	0.5000	0.5000	2.25	15.88	17.96	35.32	8.00	6.25	16.0	0.75	0.6562	3.00	2.30
329AT	888	11.40	0.5000	0.5000	3.00	0.5000	0.5000	2.25	15.88	19.96	37.94	8.00	6.25	18.0	0.75	0.6562	3.00	2.30

Frame	DIMENSIONS IN INCHES															
	AA=1.25					AA=2.00					AA=3.00					
	AB	AC	AF	XL	XN	AB	AC	AF	XL	XN	AB	AC	AF	XL	XN	
210	9.620	7.56	3.62	5.94	4.38	11.48	8.920	4.62	7.38	5.38	Not Available					
250	10.62	8.56	3.62	5.94	4.38	11.74	9.180	4.62	7.38	5.38	Not Available					
280	11.34	9.28	3.62	5.94	4.38	12.46	9.900	4.62	7.38	5.38	14.90	11.28	6.62	10.50	8.56	
320	Not Available					13.44	10.88	4.62	7.38	5.38	15.12	11.50	6.62	10.50	8.56	

Frame	DIMENSIONS IN INCHES																
	N	O	P	□ U	Δ V	W	N-W	BA	FC	FN	□ FU	Δ FV	FW	FN-FW	BS	⊕ ZA	
218AT	2.91	10.46	10.42	1.375	2.5	0.16	2.75	3.50	25.97	2.45	1.125	2.0	0.2	2.25	8.360	1.5	
219AT	2.91	10.46	10.42	1.375	2.5	0.16	2.75	3.50	26.97	2.45	1.125	2.0	0.2	2.25	9.360	1.5	
2110AT	2.91	10.46	10.42	1.375	2.5	0.16	2.75	3.50	28.47	2.45	1.125	2.0	0.2	2.25	10.87	1.5	
258AT	3.41	12.46	12.42	1.625	3.0	0.16	3.25	4.25	29.39	2.95	1.375	2.5	0.2	2.75	9.650	1.5	
259AT	3.41	12.46	12.42	1.625	3.0	0.16	3.25	4.25	31.01	2.95	1.375	2.5	0.2	2.75	11.26	1.5	
287AT	3.91	13.94	13.88	1.875	3.5	0.16	3.75	4.75	33.75	3.45	1.625	3.0	0.2	3.25	10.89	1.5	
288AT	3.91	13.94	13.88	1.875	3.5	0.16	3.75	4.75	35.47	3.45	1.625	3.0	0.2	3.25	12.62	1.5	
327AT	4.41	15.94	15.88	2.125	4.0	0.16	4.25	5.25	36.69	3.95	1.875	3.5	0.2	3.75	11.80	1.5	
328AT	4.41	15.94	15.88	2.125	4.0	0.16	4.25	5.25	38.57	3.95	1.875	3.5	0.2	3.75	13.68	1.5	
329AT	4.41	15.94	15.88	2.125	4.0	0.16	4.25	5.25	41.19	3.95	1.875	3.5	0.2	3.75	16.30	1.5	

- * Dripproof, fully guarded machines can be used for wall or ceiling mounting. Assembly modifications must be made to maintain proper enclosure.
- ‡ Dimensions "D" will not be exceeded. When exact dimension is required, shims up to .03 inches may be necessary where dimension "D" is 8 inches or less. When dimension "D" is over 8 inches, shims up to .06 inch may be necessary.
- ⊕ Splashproof machines will have additional covers, increasing the overall width at the commutator end and drive end side cover openings.
- Δ "V" represents minimum length of shaft available for hubs.
- Shaft diameters 1.5 inches and smaller will come within the limits of +0.0000 inch -0.0005 inch. Diameters larger than 1.5 inches will come within the limits of +0.0000 inch -0.0010 inch. Shaft runout on diameters 1.625 inches and smaller shall not exceed .002 inch indicator reading. Diameters larger than 1.625 inches shall not exceed .003 inch indicator reading.

- ⚡ For shipping weight add 15% to net weight.
- Conduit box will be assembled on the right hand side facing the commutator end for motors, and on the left hand side facing the commutator end for generators. Conduit box will be assembled on opposite side of frame, if so specified. Conduit box may be oriented to accommodate customers' application. Dimensions pertaining to conduit boxes vary according to rating. Refer to **Wolong** for dimensions.
- The standard single shaft machine has the commutator end bearing bracket and shaft prepared to accept accessories. For additional information, see page 4.48.
- Commutator end shaft extension is furnished only when specifically ordered, and is prepared for accessory drive.

Frames 218ATC to 329ATC

Type C-Face Mounting with Feet

Dripproof Fully Guarded*, Splashproof* and Totally Enclosed Nonventilated

Type CD

DIMENSIONS - For ESTIMATING ONLY unless endorsed for construction

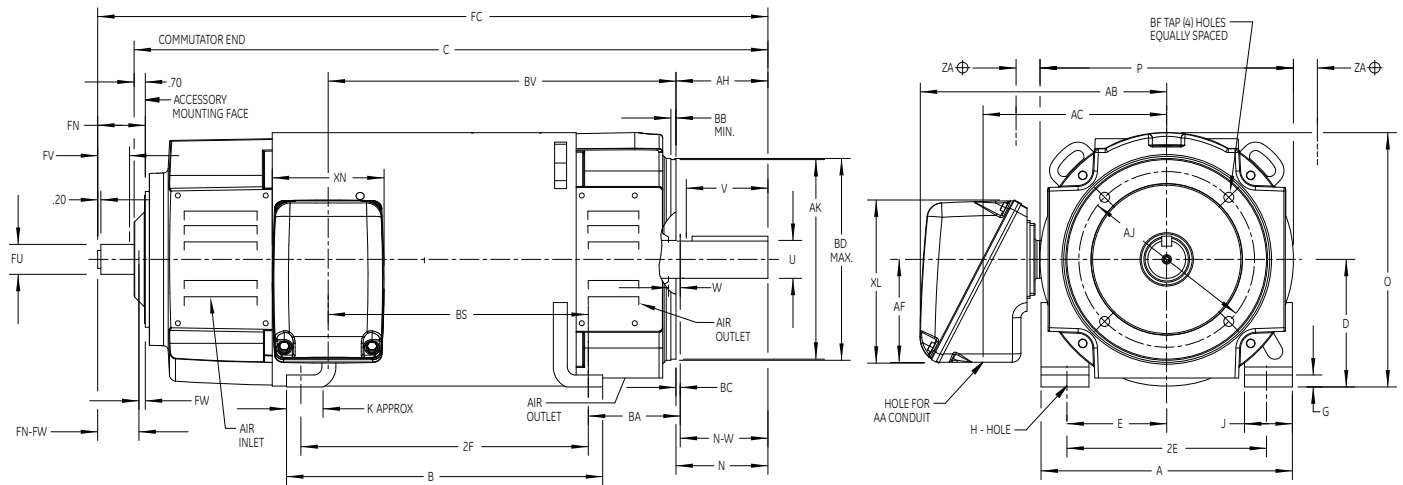

Frame	Approx. Net Wt. In Lb. Ⓢ	Approx. WK ² of Arm Lb. Ft. ²	Drive End Key			Commutator End Key			DIMENSIONS IN INCHES																
			Width	Thick	Lgth. ±.03	Width	Thick	Lgth. ±.03	A Max.	B Max.	C	± D	E	2F	G	H	J	K	N	O	P	□ U	△ V	W	N-W
218ATC	243	1.35	0.3125	0.3125	1.75	0.2500	0.2500	1.00	10.40	11.56	24.22	5.25	4.25	10.0	0.50	0.4062	2.0	2.2	2.97	10.46	10.42	1.375	2.5	0.22	2.75
219ATC	261	1.49	0.3125	0.3125	1.75	0.2500	0.2500	1.00	10.40	12.56	25.22	5.25	4.25	11.0	0.50	0.4062	2.0	2.2	2.97	10.46	10.42	1.375	2.5	0.22	2.75
2110ATC	289	1.71	0.3125	0.3125	1.75	0.2500	0.2500	1.00	10.40	14.06	26.72	5.25	4.25	12.5	0.50	0.4062	2.0	2.2	2.70	10.46	10.42	1.375	1.5	0.22	2.75
258ATC	378	2.91	0.3750	0.3750	2.25	0.3125	0.3125	1.50	12.40	14.06	27.14	6.25	5.00	12.5	0.62	0.5312	2.3	2.0	3.47	12.46	12.42	1.625	3.0	0.22	3.25
259ATC	420	3.31	0.3750	0.3750	2.25	0.3125	0.3125	1.50	12.40	15.56	28.76	6.25	5.00	14.0	0.62	0.5312	2.3	2.0	3.47	12.46	12.42	1.625	3.0	0.22	3.25
287ATC	522	4.67	0.5000	0.5000	2.50	0.3750	0.3750	2.00	13.88	14.16	30.98	7.00	5.50	12.5	0.64	0.5312	2.5	2.0	3.97	13.94	13.88	1.875	3.5	0.22	3.75
288ATC	577	5.36	0.5000	0.5000	2.50	0.3750	0.3750	2.00	13.88	15.66	32.72	7.00	5.50	14.0	0.64	0.5312	2.5	2.0	3.97	13.94	13.88	1.875	3.5	0.22	3.75
327ATC	720	8.45	0.5000	0.5000	3.00	0.5000	0.5000	2.25	15.88	15.96	33.44	8.00	6.25	14.0	0.75	0.6562	3.0	2.3	4.47	15.94	15.88	2.125	4.0	0.22	4.25
328ATC	798	9.67	0.5000	0.5000	3.00	0.5000	0.5000	2.25	15.88	17.96	35.32	8.00	6.25	16.0	0.75	0.6562	3.0	2.3	4.47	15.94	15.88	2.125	4.0	0.22	4.25
329ATC	917	11.4	0.5000	0.5000	3.00	0.5000	0.5000	2.25	15.88	19.96	37.94	8.00	6.25	18.0	0.75	0.6562	3.0	2.3	4.47	15.94	15.88	2.125	4.0	0.22	4.25

Frame	DIMENSIONS IN INCHES																	
	BA	BB Min.	FN	FU	BC	BF		△ FV	FW	FN-FW	AH	AJ	AK	⌀ ZA	Max	BV	BS	FC
						Tap	Depth											
218ATC	3.5	0.3	2.45	1.125	0.25	.500-13	1.00	2.0	0.2	2.25	2.5	7.250	8.50	1.5	9.000	12.11	8.360	25.97
219ATC	3.5	0.3	2.45	1.125	0.25	.500-13	1.00	2.0	0.2	2.25	2.5	7.250	8.50	1.5	9.000	13.11	9.360	26.97
2110ATC	3.5	0.3	2.45	1.125	0.25	.500-13	1.00	2.0	0.2	2.75	2.5	7.250	8.50	1.5	9.000	14.62	10.87	28.47
258ATC	4.25	0.3	2.95	1.375	0.24	.500-13	1.00	2.5	0.2	2.75	3.0	7.250	8.50	1.5	10.00	14.14	9.650	29.39
259ATC	4.25	0.3	2.95	1.375	0.24	.500-13	1.00	2.5	0.2	2.75	3.0	7.250	8.50	1.5	10.00	15.75	11.26	31.01
287ATC	4.75	0.3	3.45	1.625	0.24	.500-13	1.00	3.0	0.2	3.25	3.5	9.000	10.5	1.5	11.25	15.88	10.87	33.73
288ATC	4.75	0.3	3.45	1.625	0.24	.500-13	1.00	3.0	0.2	3.25	3.5	9.000	10.5	1.5	11.25	17.61	12.62	35.47
327ATC	5.25	0.3	3.95	1.875	0.24	.625-11	1.25	3.5	0.2	3.75	4.0	11.00	12.5	1.5	14.00	17.29	11.80	36.69
328ATC	5.25	0.3	3.95	1.875	0.24	.625-11	1.25	3.5	0.2	3.75	4.0	11.00	12.5	1.5	14.00	19.17	13.68	38.57
329ATC	5.25	0.3	3.95	1.875	0.24	.625-11	1.25	3.5	0.2	3.75	4.0	11.00	12.5	1.5	14.00	21.79	13.68	41.19

Frame	DIMENSIONS IN INCHES														
	AA=1.25					AA=2.0					AA=3.0				
	AB	AC	AF	XL	XN	AB	AC	AF	XL	XN	AB	AC	AF	XL	XN
210	9.620	7.56	3.62	5.94	4.38	11.48	8.920	4.62	7.38	5.38	Not Available				
250	10.62	8.56	3.62	5.94	4.38	11.74	9.180	4.62	7.38	5.38	Not Available				
280	11.34	9.28	3.62	5.94	4.38	12.46	9.900	4.62	7.38	5.38	14.90	11.28	6.62	10.5	8.56
320	Not Available					13.44	10.88	4.62	7.38	5.38	15.12	11.50	6.62	10.5	8.56

- * Dripproof, fully guarded machines can be used for wall or ceiling mounting. Assembly modifications must be made to maintain proper enclosure.
- ‡ Dimensions "D" will not be exceeded. When exact dimension is required, shims up to .03 inches may be necessary where dimension "D" is 8 inches or less. When dimension "D" is over 8 inches, shims up to .06 inch may be necessary.
- ⊕ Splashproof machines will have additional covers, increasing the overall width at the commutator end and drive end side cover openings.
- △ "V" represents minimum length of shaft available for hubs.
- Shaft diameters 1.5 inches and smaller will come within the limits of +0.0000 inch -0.0005 inch. Diameters larger than 1.5 inches will come within the limits of +0.0000 inch -0.0010 inch. Shaft runout on diameters 1.625 inches and smaller shall not exceed .002 inch indicator reading. Diameters larger than 1.625 inches shall not exceed .003 inch indicator reading.

- ⊕ For shipping weight add 15% to net weight.
- Conduit box will be assembled on the right hand side facing the commutator end for motors, and on the left hand side facing the commutator end for generators. Conduit box will be assembled on opposite side of frame, if so specified. Conduit box may be oriented to accommodate customers' application. Dimensions pertaining to conduit boxes vary according to rating. Refer to Wologong for dimensions.
- For frames CD218ATC thru CD288ATC inclusive, mounting face will be square and rabbit diameter concentric with shaft within 0.004 inch total indicator reading. "AK" dimension: +0.000 inch -0.005 inch.
- For frames CD327ATC thru CD328ATC inclusive, mounting face will be square and rabbit diameter concentric with shaft within 0.004 inch total indicator reading. "AK" dimensions: +0.000 inch -0.005 inch.
- Commutator end shaft extension is furnished only when specifically ordered, and is prepared for accessory drive.

From 36C697102CA

Outline Dimensions

Frames 218ATD to 329ATD

Type D-Flange Mounting with Feet

Dripproof Fully Guarded*, Splashproof* and Totally Enclosed Nonventilated

Type CD

DIMENSIONS - For ESTIMATING ONLY unless endorsed for construction

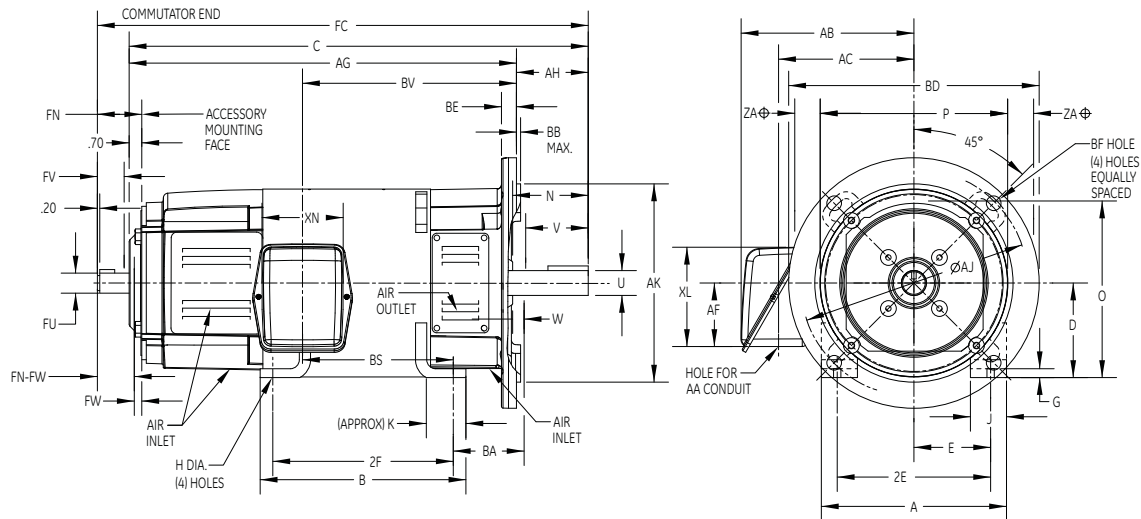

Frame	Approx. Net Wt. In Lb. ⚡	Approx. WK ² of Arm Lb. Ft. ²	DIMENSIONS IN INCHES																						
			Drive End Key			Commutator End Key			DIMENSIONS IN INCHES																
			Width	Thick	Lgth. ±.03	Width	Thick	Lgth. ±.03	A Max.	B Max.	C	± D	E	2F	G	H	J	K	N	O	P	U	V	W	BA
218ATD	264	1.35	0.3125	0.3125	1.75	0.250	0.2500	1.00	10.40	11.56	24.22	5.25	4.25	10.0	0.50	0.4062	2.00	2.2	2.97	10.46	10.42	1.375	2.5	0.22	3.50
219ATD	282	1.49	0.3125	0.3125	1.75	0.250	0.2500	1.00	10.40	12.56	25.22	5.25	4.25	11.0	0.50	0.4062	2.00	2.2	2.97	10.46	10.42	1.375	2.5	0.22	3.50
2110ATD	310	1.71	0.3125	0.3125	1.75	0.250	0.2500	1.00	10.40	14.06	26.72	5.25	4.25	12.5	0.50	0.4062	2.00	2.2	2.97	10.46	10.42	1.375	2.5	0.22	3.50
258ATD	416	2.91	0.3750	0.3750	2.25	0.313	0.3125	1.50	12.40	14.06	27.14	6.25	5.00	12.5	0.62	0.5312	2.25	2.0	3.47	12.46	12.42	1.625	3.0	0.22	4.25
259ATD	458	3.31	0.3750	0.3750	2.25	0.313	0.3125	1.50	12.40	15.56	28.76	6.25	5.00	14.0	0.62	0.5312	2.25	2.0	3.47	12.46	12.42	1.625	3.0	0.22	4.25
287ATD	551	4.67	0.5000	0.5000	2.50	0.375	0.3750	2.00	13.88	14.16	30.98	7.00	5.50	12.5	0.64	0.5312	2.50	2.0	3.97	13.94	13.88	1.875	3.5	0.22	4.75
288ATD	606	5.36	0.5000	0.5000	2.50	0.375	0.3750	2.00	13.88	15.66	32.72	7.00	5.50	14.0	0.64	0.5312	2.50	2.0	3.97	13.94	13.88	1.875	3.5	0.22	4.75
327ATD	745	8.45	0.5000	0.5000	3.00	0.500	0.5000	2.25	15.88	15.96	33.44	8.00	6.25	14.0	0.75	0.6562	3.00	2.3	4.47	15.94	15.88	2.125	4.0	0.22	5.75
328ATD	823	9.67	0.5000	0.5000	3.00	0.500	0.5000	2.25	15.88	17.96	35.32	8.00	6.25	16.0	0.75	0.6562	3.00	2.3	4.47	15.94	15.88	2.125	4.0	0.22	5.75
329ATD	942	11.4	0.5000	0.5000	3.00	0.500	0.5000	2.25	15.88	19.96	37.94	8.00	6.25	18.0	0.75	0.6562	3.00	2.3	4.47	15.94	15.88	2.125	4.0	0.22	5.75

Frame	DIMENSIONS IN INCHES																
	BB Max	BD	BE	BF	BV	FC	FN	Δ	FV	FW	FN-FW	AG	AH	AJ	AK	BS	⊕ ZA
218ATD	0.25	14	0.75	0.8125	11.86	25.97	2.45	1.125	2.0	0.2	2.25	21.47	2.75	12.5	11	8.360	1.5
219ATD	0.25	14	0.75	0.8125	12.86	26.97	2.45	1.125	2.0	0.2	2.25	22.47	2.75	12.5	11	9.360	1.5
2110ATD	0.25	14	0.75	0.8125	14.86	28.47	2.45	1.125	2.0	0.2	2.25	23.97	2.75	12.5	11	10.86	1.5
258ATD	0.25	18	0.75	0.8125	13.89	29.39	2.95	1.375	2.5	0.2	2.75	23.89	3.25	16.0	14	9.640	1.5
259ATD	0.25	18	0.75	0.8125	15.50	31.01	2.95	1.375	2.5	0.2	2.75	25.51	3.25	16.0	14	11.26	1.5
287ATD	0.25	18	0.75	0.8125	15.63	33.73	3.45	1.625	3.0	0.2	3.25	27.23	3.75	16.0	14	10.83	1.5
288ATD	0.25	18	0.75	0.8125	17.37	35.47	3.45	1.625	3.0	0.2	3.25	28.97	3.75	16.0	14	12.62	1.5
327ATD	0.25	18	0.75	0.8125	17.04	36.69	3.95	1.875	3.5	0.2	3.75	29.19	4.25	16.0	14	11.80	1.5
328ATD	0.25	18	0.75	0.8125	18.92	38.57	3.95	1.875	3.5	0.2	3.75	31.07	4.25	16.0	14	13.68	1.5
329ATD	0.25	18	0.75	0.8125	21.54	41.19	3.95	1.875	3.5	0.2	3.75	33.69	4.25	16.0	14	16.30	1.5

Frame	DIMENSIONS IN INCHES														
	AA=1.25					AA=2.0					AA=3.0				
	AB	AC	AF	XL	XN	AB	AC	AF	XL	XN	AB	AC	AF	XL	XN
210	9.620	7.56	3.62	5.94	4.38	11.48	8.920	4.62	7.38	5.38	Not Available				
250	10.62	8.56	3.62	5.94	4.38	11.74	9.180	4.62	7.38	5.38	Not Available				
280	11.34	9.28	3.62	5.94	4.38	12.46	9.900	4.62	7.38	5.38	14.90	11.28	6.62	10.5	8.56
320	Not Available					13.44	10.88	4.62	7.38	5.38	15.12	11.50	6.62	10.5	8.56

- * Dripproof, fully guarded machines can be used for wall or ceiling mounting. Assembly modifications must be made to maintain proper enclosure.
- ‡ Dimensions "D" will not be exceeded. When exact dimension is required, shims up to .03 inches may be necessary where dimension "D" is 8 inches or less. When dimension "D" is over 8 inches, shims up to .06 inch may be necessary.
- ⊕ Splashproof machines will have additional covers, increasing the overall width at the commutator end and drive end side cover openings.
- Δ "V" represents minimum length of shaft available for hubs.
- Shaft diameters 1.5 inches and smaller will come within the limits of +0.0000 inch -0.0005 inch. Diameters larger than 1.5 inches will come within the limits of +0.0000 inch -0.0010 inch. Shaft runout on diameters 1.625 inches and smaller shall not exceed .002 inch indicator reading. Diameters larger than 1.625 inches shall not exceed .003 inch indicator reading.

- ⚡ For shipping weight add 15% to net weight.
- Conduit box will be assembled on the right hand side facing the commutator end for motors, and on the left hand side facing the commutator end for generators. Conduit box will be assembled on opposite side of frame, if so specified. Conduit box may be oriented to accommodate customers' application. Dimensions pertaining to conduit boxes vary according to rating. Refer to **Wolong** for dimensions.
- For frames CD218ATC thru CD288ATC inclusive, mounting face will be square and rabbit diameter concentric with shaft within 0.004 inch total indicator reading. "AK" dimension: +0.000 inch -0.005 inch.
- For frames CD327ATC thru CD328ATC inclusive, mounting face will be square and rabbit diameter concentric with shaft within 0.004 inch total indicator reading. "AK" dimensions: +0.000 inch -0.005 inch.
- Commutator end shaft extension is furnished only when specifically ordered, and is prepared for accessory drive.

From 36C697102DA

DIMENSIONS - For ESTIMATING ONLY unless endorsed for construction

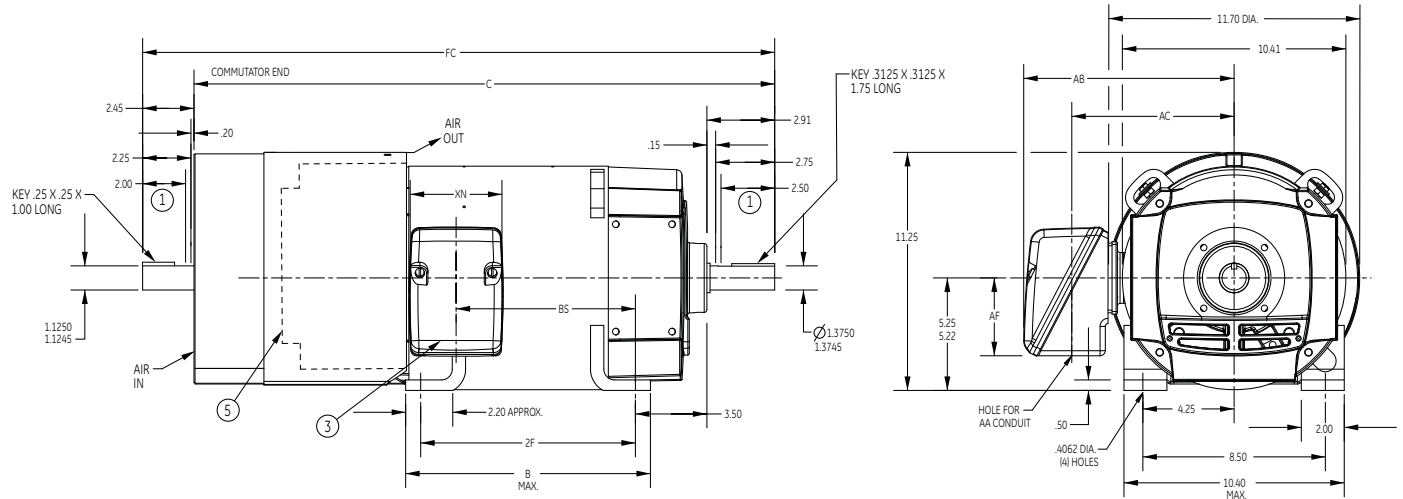

Frame	B	C	FC	2F	BS	Approx. Net Wt. ⚡
218AT	11.56	26.82	29.34	10.0	8.360	241
219AT	12.56	27.82	30.34	11.0	9.360	259
2110AY	14.06	29.32	31.84	12.5	10.87	287

AA	Conduit Box Dimensions			XL	XN
	AB	AC	AF		
1.25	9.620	7.56	3.62	5.94	4.38
2	11.48	8.92	4.62	7.38	5.38

- ① Represents minimum length of shaft available for hubs.
- ② Machine can be used for wall or ceiling mounting.
- ③ Conduit box will be assembled on the right hand side facing the commutator end for motors, and on the left hand side facing the commutator end for generators. Conduit box will be assembled on opposite side of frame, if so specified. Conduit box may be oriented to accommodate customers' application. Dimensions pertaining to conduit boxes vary according to rating.

- ④ Shaft runout shall not exceed 0.002 inch total indicator reading on drive end.
- ⑤ Shroud is removable to permit access to hand hole covers.
- ⑥ Commutator end shaft extension is furnished only when specifically ordered.
- ⚡ For shipping weight, add 15% to net weight.

DIMENSIONS - For ESTIMATING ONLY unless endorsed for construction

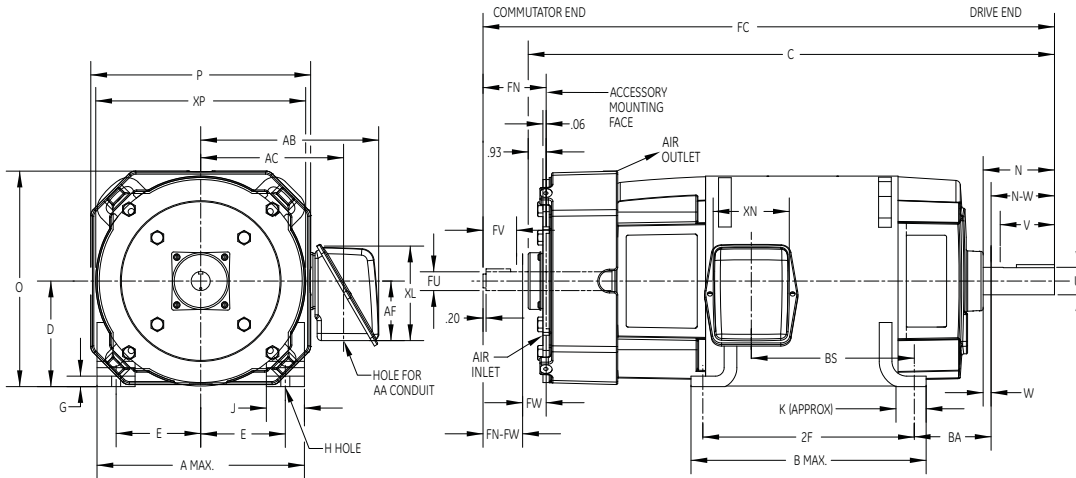

Frame	Approx. Net Wt. In Lb. ⬠	Approx. WK² of Arm Lb. Ft.²	Drive End		Commutator			DIMENSIONS IN INCHES										
			Key		End Key			A Max.	B Max.	C	‡ D	E	2F	G	H	J	K	
			Width	Thick	Lgth. ±.03	Width	Thick											Lgth. ±.03
258AT	397	3.170	0.375	0.375	2.25	0.3125	0.3125	1.50	12.40	14.06	30.32	6.25	5.00	12.5	0.62	0.5312	2.25	2.0
259AT	442	3.570	0.375	0.375	2.25	0.3125	0.3125	1.50	12.40	15.56	31.94	6.25	5.00	14.0	0.62	0.5312	2.25	2.0
287AT	532	5.090	0.500	0.500	2.50	0.3750	0.3750	2.00	13.88	14.16	34.66	7.00	5.50	12.5	0.64	0.5312	2.50	2.0
288AT	587	5.780	0.500	0.500	2.50	0.3750	0.3750	2.00	13.88	15.66	36.40	7.00	5.50	14.0	0.64	0.5312	2.50	2.0
327AT	732	9.200	0.500	0.500	3.00	0.5000	0.5000	2.25	15.88	15.96	37.62	8.00	6.25	14.0	0.75	0.6562	3.00	2.3
328AT	812	10.42	0.500	0.500	3.00	0.5000	0.5000	2.25	15.88	17.96	39.50	8.00	6.25	16.0	0.75	0.6562	3.00	2.3

Frame	DIMENSIONS IN INCHES															
	N	O	P	□ U	Δ V	W	N-W	BA	FC	FN	□ FU	Δ FV	FW	FN-FW	BS	XP
258AT	3.41	12.75	13.00	1.625	3.0	0.16	3.25	4.25	32.64	3.25	1.375	2.5	0.5	2.75	9.650	12.42
259AT	3.41	12.75	13.00	1.625	3.0	0.16	3.25	4.25	34.26	3.25	1.375	2.5	0.5	2.75	11.26	12.42
287AT	3.91	14.25	14.52	1.875	3.5	0.16	3.75	4.75	37.48	3.75	1.625	3.0	0.5	3.25	10.89	13.88
288AT	3.91	14.25	14.52	1.875	3.5	0.16	3.75	4.75	39.22	3.75	1.625	3.0	0.5	3.25	12.62	13.88
327AT	4.41	16.25	16.52	2.125	4.0	0.16	4.25	5.25	40.94	4.25	1.875	3.5	0.5	3.75	11.80	15.88
328AT	4.41	16.25	16.52	2.125	4.0	0.16	4.25	5.25	42.82	4.25	1.875	3.5	0.5	3.75	13.68	15.88

Frame	DIMENSIONS IN INCHES														
	AA=1.25					AA=2.0					AA=3.0				
	AB	AC	AF	XL	XN	AB	AC	AF	XL	XN	AB	AC	AF	XL	XN
210	9.620	7.56	3.62	5.94	4.38	11.48	8.920	4.62	7.38	5.38	Not Available				
250	10.62	8.56	3.62	5.94	4.38	11.74	9.180	4.62	7.38	5.38	Not Available				
280	11.34	9.28	3.62	5.94	4.38	12.46	9.900	4.62	7.38	5.38	14.90	11.28	6.62	10.5	8.56
320	Not Available					13.44	10.88	4.62	7.38	5.38	15.12	11.50	6.62	10.5	8.56

Outline Dimensions

- ‡ Dimensions "D" will not be exceeded. When exact dimension is required, shims up to .03 inches may be necessary where dimension "D" is 8 inches or less. When dimension "D" is over 8 inches, shims up to .06 inch may be necessary.
- Δ "V" represents minimum length of shaft available for hubs.
- Shaft diameters 1.5 inches and smaller will come within the limits of +0.0000 inch -0.0005 inch. Diameters larger than 1.5 inches will come within the limits of +0.0000 inch -0.0010 inch. Shaft runout on diameters 1.625 inches and smaller shall not exceed .002 inch indicator reading. Diameters larger than 1.625 inches shall not exceed .003 inch indicator reading.

- ⬠ For shipping weight add 15% to net weight.
- Conduit box will be assembled on the right hand side facing the commutator end for motors, and on the left hand side facing the commutator end for generators. Conduit box will be assembled on opposite side of frame, if so specified. Conduit box may be oriented to accommodate customers' application. Dimensions pertaining to conduit boxes vary according to rating. Refer to **Wolong** for dimensions.
- The standard single shaft machine has the commutator end bearing bracket and shaft prepared to accept accessories. For additional information, see page 4.48.
- Commutator end shaft extension is furnished only when specifically ordered, and is prepared for accessory drive.
- When commutator end shaft is not furnished, shaft and fan shroud on commutator end is prepared for shaft driven accessories. Refer to 36C697103BA for dimensions.

DIMENSIONS - For ESTIMATING ONLY unless endorsed for construction

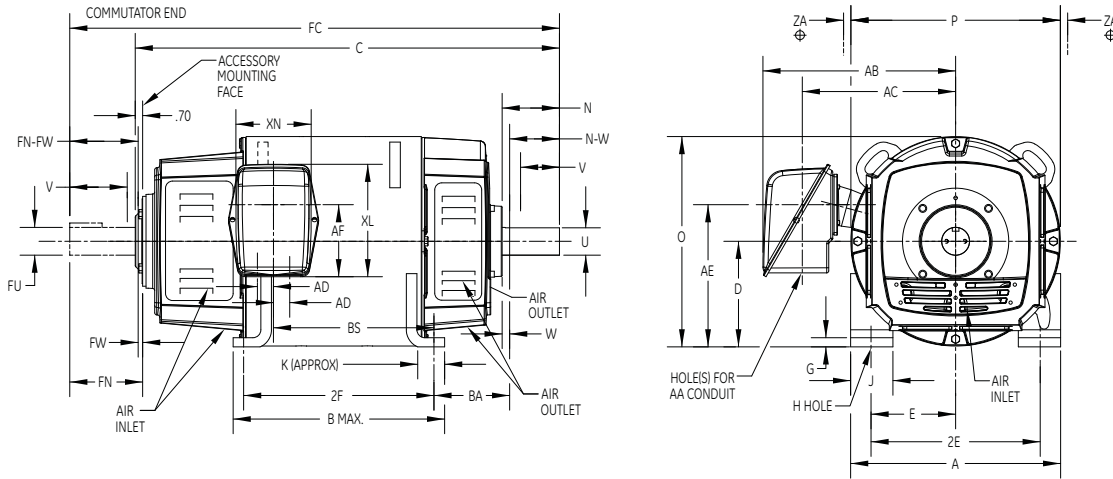

Frame	Approx. Net Wt. In Lb. ♂	Approx. WK ² of Arm Lb. Ft. ²	Drive End			Commutator			DIMENSIONS IN INCHES										
			Key			End Key			A Max.	B Max.	C	⌀ D	E	2F	G	H	J	K	N
			Width	Thick	Lgth. ±.03	Width	Thick	Lgth. ±.03											
365AT	750.0	15.610	0.625	0.625	3.50	0.500	0.500	3.00	17.920	14.16	33.70	9.00	7.0	12.25	0.74	0.8125	3.26	2.31	4.92
366AT	860.0	18.270	0.625	0.625	3.50	0.500	0.500	3.00	17.920	15.90	35.90	9.00	7.0	14.00	0.74	0.8125	3.26	2.31	4.92
368AT	1020	22.210	0.625	0.625	3.50	0.500	0.500	3.00	17.920	19.90	38.90	9.00	7.0	18.00	0.74	0.8125	3.26	2.31	4.92
407AT	1300	35.470	0.625	0.625	4.00	0.625	0.625	3.50	20.000	20.16	40.12	10.0	8.0	18.00	0.86	0.9375	4.00	2.38	5.42
L407AT	1350	35.540	0.625	0.625	4.00	0.625	0.625	3.50	20.000	20.16	43.52	10.0	8.0	18.00	0.86	0.9375	4.00	2.38	5.42
409AT	1600	43.810	0.625	0.625	4.00	0.625	0.625	3.50	20.000	24.16	44.62	10.0	8.0	22.00	0.86	0.9375	4.00	2.38	5.42
L409AT	1650	43.880	0.625	0.625	4.00	0.625	0.625	3.50	20.000	24.16	48.02	10.0	8.0	22.00	0.86	0.9375	4.00	2.38	5.42
504AT	1900	79.100	0.750	0.750	5.25	0.750	0.750	4.50	24.920	18.96	45.74	12.5	10	16.00	1.11	1.1875	4.50	3.00	6.67
L504AT	2070	79.150	0.750	0.750	5.25	0.750	0.750	4.50	24.920	18.96	47.50	12.5	10	16.00	1.11	1.1875	4.50	3.00	6.67
506AT	2290	98.760	0.750	0.750	5.25	0.750	0.750	4.50	24.920	22.96	49.74	12.5	10	20.00	1.11	1.1875	4.50	3.00	6.67
L506AT	2440	98.810	0.750	0.750	5.25	0.750	0.750	4.50	24.920	22.96	51.50	12.5	10	20.00	1.11	1.1875	4.50	3.00	6.67
508AT	2810	121.87	0.750	0.750	5.25	0.750	0.750	4.50	24.920	27.96	54.74	12.5	10	25.00	1.11	1.1875	4.50	3.00	6.67
L508AT	2970	122.92	0.750	0.750	5.25	0.750	0.750	4.50	24.920	27.96	56.50	12.5	10	25.00	1.11	1.1875	4.50	3.00	6.67
5010AY	4260	157.28	1.000	1.000	6.50	0.750	0.750	5.25	24.920	34.86	65.49	12.5	10	32.00	1.11	1.1875	4.50	3.00	8.42

Frame	DIMENSIONS IN INCHES																⌀ ZA	
	O	P	□ U	Δ V	W	N-W	BA	FC	FN	□ FU	Δ FV	FW	FN-FW	BS				
														AA=3"	AA=4"	AA=(2) 4"		AA=Blank
365AT	17.91	17.90	2.375	4.50	0.17	4.75	5.875	37.45	4.45	2.125	4.00	0.2	4.25	9.020	9.02	6.640	-	0.25
366AT	17.91	17.90	2.375	4.50	0.17	4.75	5.875	39.65	4.45	2.125	4.00	0.2	4.25	11.22	11.22	8.840	-	0.25
368AT	17.91	17.90	2.375	4.50	0.17	4.75	5.875	42.65	4.45	2.125	4.00	0.2	4.25	14.22	14.22	11.84	-	0.25
407AT	20.15	20.38	2.625	5.00	0.17	5.25	6.625	44.37	4.95	2.375	4.50	0.2	4.75	15.18	15.18	12.80	12.80	-
L407AT	20.15	20.38	2.625	5.00	0.17	5.25	6.625	47.77	4.95	2.375	4.50	0.2	4.75	15.18	15.18	12.80	12.80	-
409AT	20.15	20.38	2.625	5.00	0.17	5.25	6.625	48.87	4.95	2.375	4.50	0.2	4.75	19.68	19.68	17.30	17.30	-
L409AT	20.15	20.38	2.625	5.00	0.17	5.25	6.625	52.27	4.95	2.375	4.50	0.2	4.75	19.68	19.68	17.30	17.30	-
504AT	25.15	25.38	3.250	6.25	0.17	6.50	8.500	50.99	5.95	2.875	5.50	0.2	5.75	-	13.26	10.88	10.88	-
L504AT	25.15	25.38	3.250	6.25	0.17	6.50	8.500	52.75	5.95	2.875	5.50	0.2	5.75	-	-	-	11.16	-
506AT	25.15	25.38	3.250	6.25	0.17	6.50	8.500	54.99	5.95	2.875	5.50	0.2	5.75	-	17.26	14.88	14.88	-
L506AT	25.15	25.38	3.250	6.25	0.17	6.50	8.500	56.75	5.95	2.875	5.50	0.2	5.75	-	-	-	15.16	-
508AT	25.15	25.38	3.250	6.25	0.17	6.50	8.500	59.99	5.95	2.875	5.50	0.2	5.75	-	22.26	19.88	19.88	-
L508AT	25.15	25.38	3.250	6.25	0.17	6.50	8.500	61.75	5.95	2.875	5.50	0.2	5.75	-	-	-	20.16	-
5010AY	25.17	25.38	4.125	8.00	0.17	8.25	8.500	71.49	6.70	3.25	6.25	0.2	6.25	-	31.26	28.88	28.88	-

* Dripproof, fully guarded machines can be used for wall or ceiling mounting. Assembly modifications must be made to maintain proper enclosure.

‡ Dimensions "D" will not be exceeded. When exact dimension is required, shims up to .03 inches may be necessary where dimension "D" is 8 inches or less. When dimension "D" is over 8 inches, shims up to .06 inch may be necessary.

♣ Splashproof machines will have additional covers, increasing the overall width at the commutator end and drive end side cover openings.

Δ "V" represents minimum length of shaft available for hubs.

□ Shaft diameters 1.5 inches and smaller will come within the limits of +0.0000 inch -0.0005 inch. Diameters larger than 1.5 inches will come within the limits of +0.0000 inch -0.0010 inch. Shaft runout on diameters 1.625 inches and smaller shall not exceed .002 inch indicator reading. Diameters larger than 1.625 inches shall not exceed .003 inch indicator reading.

♢ For shipping weight add 15% to net weight.

Conduit box will be assembled on the right hand side facing the commutator end for motors, and on the left hand side facing the commutator end for generators. Conduit box will be assembled on opposite side of frame, if so specified. Conduit box may be oriented to accommodate customers' application. Dimensions pertaining to conduit boxes vary according to rating. Refer to **Wolong** for dimensions. The standard single shaft machine has the commutator end bearing bracket and shaft prepared to accept accessories. For additional information, see page 4.48. Commutator end shaft extension is furnished only when specifically ordered, and is prepared for accessory drive.

Outline Dimensions

Frames 365ATD TO L508ATD

Type D-Flange Mounting with Feet

Dripproof Fully Guarded*, Splashproof* and Totally Enclosed Nonventilated

Type CD

DIMENSIONS - For ESTIMATING ONLY unless endorsed for construction

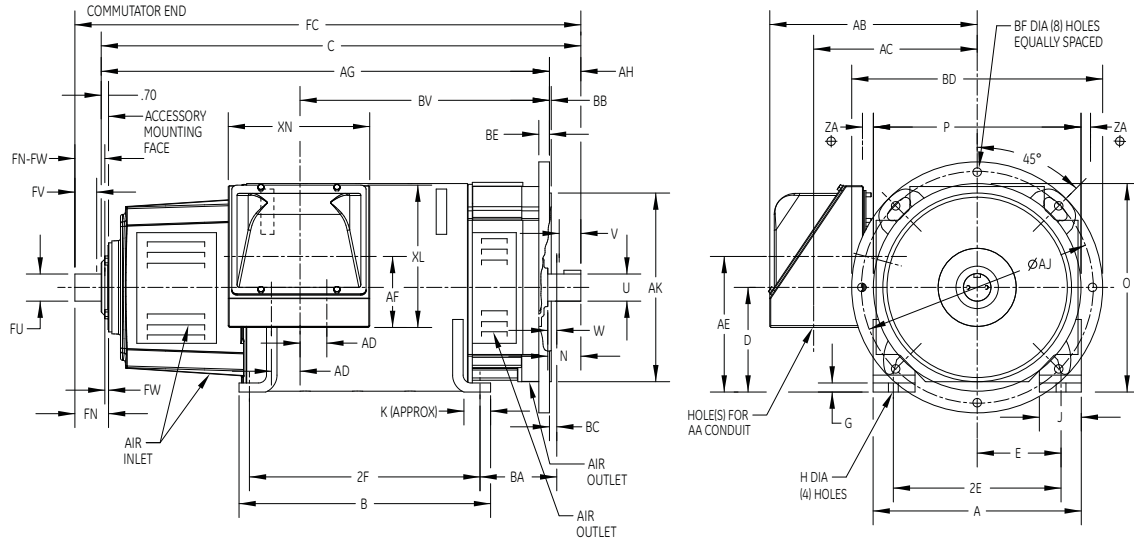

Frame	Approx. Net Wt. In Lb. ◊	Approx. WK ² of Arm Lb. Ft. ²	Drive End		Commutator			DIMENSIONS IN INCHES												
			Key		End Key			A Max.	B Max.	C	‡ D	E	2F	G	H	J	K	N	O	
			Width	Thick	Lgth. ±.03	Width	Thick													Lgth. ±.03
365ATD	820.0	15.610	0.625	0.625	3.50	0.500	0.500	3.0	17.92	14.16	33.70	9.00	7.0	12.25	0.74	0.8125	3.26	2.31	4.92	17.91
366ATD	930.0	18.270	0.625	0.625	3.50	0.500	0.500	3.0	17.92	15.90	35.90	9.00	7.0	14.00	0.74	0.8125	3.26	2.31	4.92	17.91
368ATD	1090	22.210	0.625	0.625	3.50	0.500	0.500	3.0	17.92	19.90	38.9	9.00	7.0	18.00	0.74	0.8128	3.26	2.31	4.92	17.91
407ATD	1380	35.470	0.625	0.625	4.00	0.625	0.625	3.5	20.00	20.16	40.12	10.0	8.0	18.00	0.86	0.9375	4.00	2.38	5.42	20.15
L407ATD	1430	35.540	0.625	0.625	4.00	0.625	0.625	3.5	20.00	20.16	43.52	10.0	8.0	18.00	0.86	0.9375	4.00	2.38	5.42	20.15
409ATD	1680	43.810	0.625	0.625	4.00	0.625	0.625	3.5	20.00	24.16	44.62	10.0	8.0	22.00	0.86	0.9375	4.00	2.38	5.42	20.15
L409ATD	1730	43.880	0.625	0.625	4.00	0.625	0.625	3.5	20.00	24.16	48.02	10.0	8.0	22.00	0.86	0.9375	4.00	2.38	5.42	20.15
504ATD	2000	79.100	0.750	0.750	5.25	0.750	0.750	4.5	24.92	18.96	45.74	12.5	10	16.00	1.11	1.1875	4.50	3.00	6.67	25.15
L504ATD	2170	79.150	0.750	0.750	5.25	0.750	0.750	4.5	24.92	18.96	47.50	12.5	10	16.00	1.11	1.1875	4.50	3.00	6.67	25.15
506ATD	2390	98.760	0.750	0.750	5.25	0.750	0.750	4.5	24.92	22.96	49.74	12.5	10	20.00	1.11	1.1875	4.50	3.00	6.67	25.15
L506ATD	2540	98.810	0.750	0.750	5.25	0.750	0.750	4.5	24.92	22.96	51.50	12.5	10	20.00	1.11	1.1875	4.50	3.00	6.67	25.15
508ATD	2910	121.87	0.750	0.750	5.25	0.750	0.750	4.5	24.92	27.96	54.75	12.5	10	25.00	1.11	1.1875	4.50	3.00	6.67	25.15
L508ATD	3070	122.92	0.750	0.750	5.25	0.750	0.750	4.5	24.92	27.96	56.50	12.5	10	25.00	1.11	1.1875	4.50	3.00	6.67	25.15

Outline Dimensions

Frame	DIMENSIONS IN INCHES																				
	P	□ U	Δ V	W	BA	BB Max	BC	BD Max	BE Nom	BF	‡ ZA	FC	FN	□ FU	Δ FV	FW	FN-FW	AG	AH	AJ	AK
365ATD	17.90	2.375	4.50	0.17	5.875	0.25	-	22	1	0.8125	1.8	37.45	4.45	2.125	4.0	0.2	4.25	28.95	4.750	20	18
366ATD	17.90	2.375	4.50	0.17	5.875	0.25	-	22	1	0.8125	1.8	39.65	4.45	2.125	4.0	0.2	4.25	31.15	4.750	20	18
368ATD	17.90	2.375	4.50	0.17	5.875	0.25	-	22	1	0.8125	1.8	42.65	4.45	2.125	4.0	0.2	4.25	34.15	4.750	20	18
407ATD	20.38	2.625	5.00	0.17	6.625	0.19	-	24	1	0.8125	1.8	44.37	4.95	2.375	4.5	0.2	4.75	34.87	5.250	22	18
L407ATD	20.38	2.625	5.00	0.17	6.625	0.19	-	24	1	0.8125	1.8	47.77	4.95	2.375	4.5	0.2	4.75	38.27	5.250	22	18
409ATD	20.38	2.625	5.00	0.17	6.625	0.19	-	24	1	0.8125	1.8	48.87	4.95	2.375	4.5	0.2	4.75	39.37	5.250	22	18
L409ATD	20.38	2.625	5.00	0.17	6.625	0.19	-	24	1	0.8125	1.8	52.27	4.95	2.375	4.5	0.2	4.75	42.77	5.250	22	18
504ATD	25.38	3.250	6.25	0.17	8.500	0.19	0.38	32	1	0.8125	2.2	50.99	5.95	2.875	5.5	0.2	5.75	38.86	6.875	30	28
L504ATD	25.38	3.250	6.25	0.17	8.500	0.19	0.38	32	1	0.8125	2.2	52.75	5.95	2.875	5.5	0.2	5.75	40.62	6.875	30	28
506ATD	25.38	3.250	6.25	0.17	8.500	0.19	0.38	32	1	0.8125	2.2	54.99	5.95	2.875	5.5	0.2	5.75	42.86	6.875	30	28
L506ATD	25.38	3.250	6.25	0.17	8.500	0.19	0.38	32	1	0.8125	2.2	56.75	5.95	2.875	5.5	0.2	5.75	44.62	6.875	30	28
508ATD	25.38	3.250	6.25	0.17	8.500	0.19	0.38	32	1	0.8125	2.2	59.99	5.95	2.875	5.5	0.2	5.75	47.86	6.875	30	28
L508ATD	25.38	3.250	6.25	0.17	8.500	0.19	0.38	32	1	0.8125	2.2	61.75	5.95	2.875	5.5	0.2	5.75	49.62	6.875	30	28

From 36C697106DA

Frames 365AT TO 5010AY

Conduit Box Dimensions

Dripproof Fully Guarded*, Splashproof† and Totally Enclosed Nonventilated

Type CD

DIMENSIONS - For ESTIMATING ONLY unless endorsed for construction

CONDUIT BOX DIMENSIONS

Frame	DIMENSIONS IN INCHES														
	AA=3"		AA=4"		AA=(2) 4"		AA= Blank		Frame	AA=4"		AA=(2) 4"		AA= Blank	
	BS	BV	BS	BV	BS	BV	BS	BV		BS	BV	BS	BV	BS	BV
365AT	9.020	14.9	9.020	14.9	6.640	12.52	-	-	504ATD	13.26	21.38	10.88	19	10.88	19.00
366AT	11.22	17.1	11.22	17.1	8.840	14.72	-	-	L504ATD	-	-	-	-	11.16	19.28
368AT	14.22	20.1	14.22	20.1	11.84	17.72	-	-	506ATD	17.26	25.38	14.88	23	14.88	23.00
407AT	-	-	-	-	-	-	-	-	L506ATD	-	-	-	-	15.16	23.28
L407AT	15.18	21.8	15.18	21.8	12.80	19.42	12.8	19.42	508ATD	22.26	30.38	19.88	28	19.88	28.00
409AT	-	-	-	-	-	-	-	-	L508ATD	-	-	-	-	20.16	28.26
L409AT	19.68	26.3	19.68	26.3	17.30	23.92	17.3	23.92							

Frame	DIMENSIONS IN INCHES																										
	AA=3"						AA=4"						AA=(2) 4"						AA= Blank 13.38" X 13.31" Available Drill Space								
	AB	AC	AE	AF	XL	XN	AB	AC	AE	AF	XL	XN	AB	AC	AD	AE	AF	XL	XN	AB	AE	AF	XL	XN			
360AT	16.08	12.33	9.000	6.44	10.12	7	17.82	13.20	9.00	8.5	13.5	8.62	18.72	14.97	3	9.000	6.75	13.5	13.5	Not Available							
400AT	17.47	13.72	12.95	6.44	10.12	7	19.22	14.60	12.95	8.5	13.5	8.62	20.12	16.37	3	12.96	6.75	13.5	13.5	24.76	12.95	6.75	13.5	13.5			
500AT	Not Available						21.70	17.08	16.10	8.5	13.5	8.62	22.60	18.85	3	16.10	6.75	13.5	13.5	27.18	16.10	6.75	13.5	13.5			
L500AT	Not Available						Not Available						Not Available						27.18	15.70	8.75	13.5	13.5				
5010AY	Not Available						21.94	17.32	16.10	8.5	13.5	8.62	22.84	19.09	3	16.10	6.75	13.5	13.5	27.42	16.10	6.75	13.5	13.5			

- * Dripproof, fully guarded machines can be used for wall or ceiling mounting. Assembly modifications must be made to maintain proper enclosure.
- † Dimensions "D" will not be exceeded. When exact dimension is required, shims up to .03 inches may be necessary where dimension "D" is 8 inches or less. When dimension "D" is over 8 inches, shims up to .06 inch may be necessary.
- ‡ Splashproof machines will have additional covers, increasing the overall width at the commutator end and drive end side cover openings.
- Δ "V" represents minimum length of shaft available for hubs.
- Shaft diameters 1.5 inches and smaller will come within the limits of +0.0000 inch -0.0005 inch. Diameters larger than 1.5 inches will come within the limits of +0.0000 inch -0.0010 inch. Shaft runout on diameters 1.625 inches and smaller shall not exceed .002 inch indicator reading. Diameters larger than 1.625 inches shall not exceed .003 inch indicator reading.

- Conduit box will be assembled on the right hand side facing the commutator end for motors, and on the left hand side facing the commutator end for generators. Conduit box will be assembled on opposite side of frame, if so specified. Conduit box may be oriented to accommodate customers' application. Dimensions pertaining to conduit boxes vary according to rating. Refer to **Wolong** for dimensions. The standard single shaft machine has the commutator end bearing bracket and shaft prepared to accept **accessories**. For additional information, see page 4.48. Commutator end shaft extension is furnished only when specifically ordered, and is prepared for accessory drive. Mounting face will be square and rabbit diameter concentric with shaft within 0.007 inch total indicator reading. "AK" dimensions: +0.000 inch -0.005 inch.
- ◇ For shipping weight add 15% to net weight.

Outline Dimensions

DIMENSIONS - For ESTIMATING ONLY unless endorsed for construction

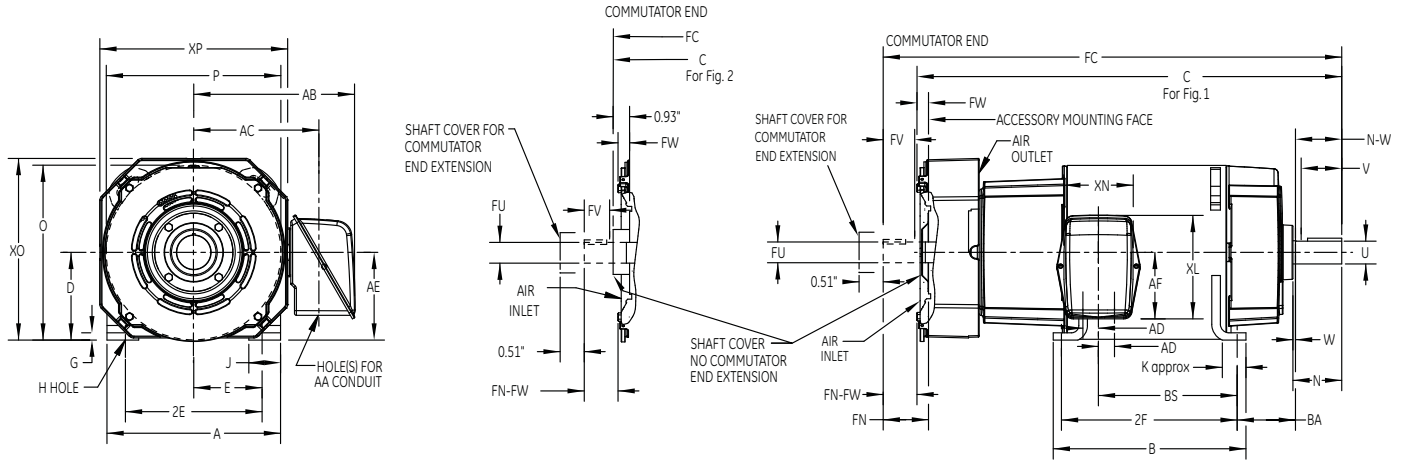

Frame	Approx. Net Wt. In Lb. ⚡	Approx. WK ² of Arm Lb. Ft. ²	Drive End		Commutator			DIMENSIONS IN INCHES											
			Key			End Key			A Max.	B Max.	C	‡ D	E	2F	G	H	J	K	N
			Width	Thick	Lgth. ±.03	Width	Thick	Lgth. ±.03											
365AT	830.0	15.61	0.625	0.625	3.5	0.500	0.500	3.0	17.92	14.16	38.22	9.0	7	12.25	0.74	0.8125	3.26	2.31	4.92
366AT	940.0	18.27	0.625	0.625	3.5	0.500	0.500	3.0	17.92	15.90	40.42	9.0	7	14.00	0.74	0.8125	3.26	2.31	4.92
368AT	1100	22.21	0.625	0.625	3.5	0.500	0.500	3.0	17.92	19.90	43.42	9.0	7	18.00	0.74	0.8125	3.26	2.31	4.92
407AT	1380	35.47	0.625	0.625	4.0	0.625	0.625	3.5	20.00	20.16	44.90	10	8	18.00	0.86	0.9375	4.00	2.38	5.42
L407AT	1430	35.54	0.625	0.625	4.0	0.625	0.625	3.5	20.00	20.16	48.30	10	8	18.00	0.86	0.9375	4.00	2.38	5.42
409AT	1680	43.81	0.625	0.625	4.0	0.625	0.625	3.5	20.00	24.16	49.40	10	8	22.00	0.86	0.9375	4.00	2.38	5.42
L409AT	1730	43.88	0.625	0.625	4.0	0.625	0.625	3.5	20.00	24.16	52.80	10	8	22.00	0.86	0.9375	4.00	2.38	5.42

Frame	DIMENSIONS IN INCHES																		
	O	P	□ U	Δ V	W	N-W	BA	FC	FN	□ FU	Δ FV	FW	FN-FW	XO	XP	BS			
	AA=3"	AA=4"	AA=[2] 4"	AA= Blank															
365AT	17.91	17.9	2.375	4.5	0.17	4.75	5.875	42.47	5.42	2.125	4.0	1.17	4.25	18.62	19.24	9.020	9.020	6.640	
366AT	17.91	17.9	2.375	4.5	0.17	4.75	5.875	44.67	5.42	2.125	4.0	1.17	4.25	18.62	19.24	11.22	11.22	8.840	
368AT	17.91	17.9	2.375	4.5	0.17	4.75	5.875	47.67	5.42	2.125	4.0	1.17	4.25	18.62	19.24	14.22	14.22	11.84	
407AT	20.15	20.38	2.625	5.0	0.17	5.25	6.625	49.39	5.42	2.375	4.5	0.67	4.75	19.62	19.24	15.18	15.18	12.80	
L407AT	20.15	20.38	2.625	5.0	0.17	5.25	6.625	52.79	5.42	2.375	4.5	0.67	4.75	19.62	19.24	15.18	15.18	12.80	
409AT	20.15	20.38	2.625	5.0	0.17	5.25	6.625	53.89	5.42	2.375	4.5	0.67	4.75	19.62	19.24	19.68	19.68	17.30	
L409AT	20.15	20.38	2.625	5.0	0.17	5.25	6.625	57.29	5.42	2.375	4.5	0.67	4.75	19.62	19.24	19.24	19.24	17.30	

Frame	DIMENSIONS IN INCHES																							
	AA=3"						AA=4"						AA=[2] 4"						AA= Blank 13.38" X 13.31" Available Drill Space					
	AB	AC	AE	AF	XL	XN	AB	AC	AE	AF	XL	XN	AB	AC	AD	AE	AF	XL	XN	AB	AE	AF	XL	XN
360AT	16.08	12.33	9.000	6.44	10.12	7	17.82	13.2	9.000	8.5	13.5	8.62	18.72	14.97	3	9.000	6.75	13.5	13.5	Not Available				
400AT	17.47	13.72	12.95	6.44	10.12	7	19.22	14.6	12.95	8.5	13.5	8.62	20.12	16.37	3	12.95	6.75	13.5	13.5	24.76	12.95	6.75	13.5	13.5

- ‡ Dimensions "D" will not be exceeded. When exact dimension is required, shims up to .03 inches may be necessary where dimension "D" is 8 inches or less. When dimension "D" is over 8 inches, shims up to .06 inch may be necessary.
- Δ "V" represents minimum length of shaft available for hubs.
- Shaft diameters 1.5 inches and smaller will come within the limits of +0.0000 inch -0.0005 inch. Diameters larger than 1.5 inches will come within the limits of +0.0000 inch -0.0010 inch. Shaft runout on diameters 1.625 inches and smaller shall not exceed .002 inch indicator reading. Diameters larger than 1.625 inches shall not exceed .003 inch indicator reading.

- ⚡ For shipping weight add 15% to net weight.
- Conduit box will be assembled on the right hand side facing the commutator end for motors, and on the left hand side facing the commutator end for generators. Conduit box will be assembled on opposite side of frame, if so specified. Conduit box may be oriented to accommodate customers' application. Dimensions pertaining to conduit boxes vary according to rating. Refer to Wolong for dimensions. Commutator end shaft extension is furnished only when specifically ordered, and is prepared for accessory drive. The standard single shaft machine has the commutator end bearing bracket and shaft prepared to accept accessories. For additional information, see page 4.48.

DIMENSIONS - For ESTIMATING ONLY unless endorsed for construction

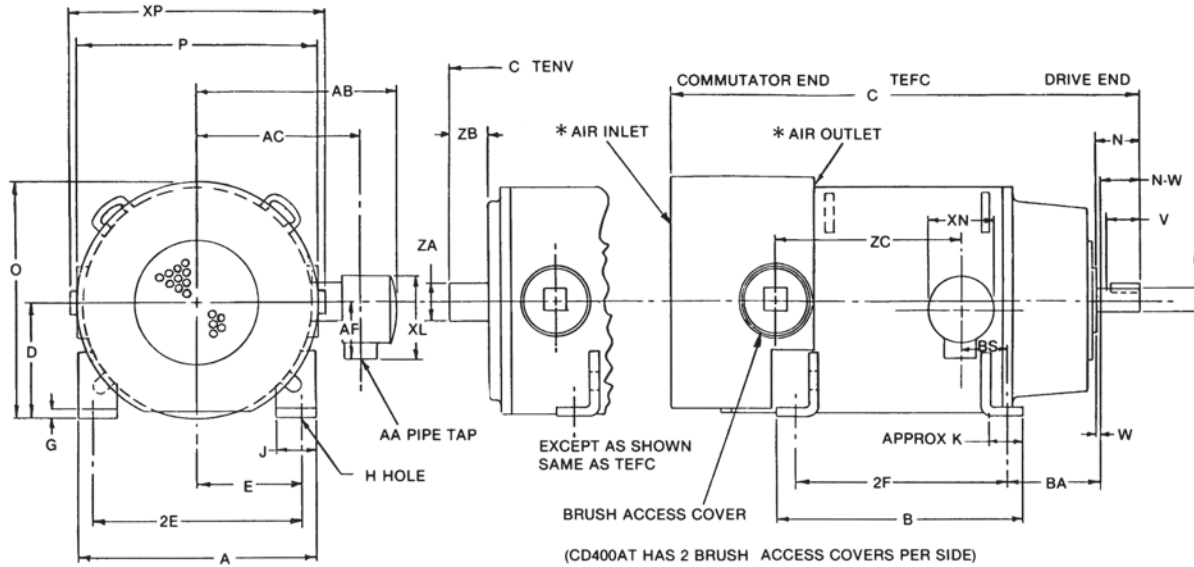

Frame	Approx. Net Wt. In Lb. ⋄	Approx. WK ² of Arm Lb. Ft. ²	Drive End			DIMENSIONS IN INCHES														TENV O	TEFC O	TENV P	TEFC P
			Key			A	B	TENV C	TEFC C	‡ D	E	2E	2F	G	H	J	K	N					
			Width	Depth	Lgth. ±.03																		
188AT	150.0	0.45	0.250	0.12	1.38	9.000	10.50	19.76	21.82	4.50	3.75	7.50	10.0	0.56	0.406	1.75	1.62	2.38	9.000	-	9.00	-	
189AT	180.0	0.67	0.250	0.12	1.38	9.000	11.50	21.76	21.82	4.50	3.75	7.50	10.0	0.56	0.406	1.75	1.62	2.38	9.000	9.520	9.00	10.88	
2110AT	340.0	1.71	0.312	0.16	1.75	10.40	14.06	28.50	28.50	5.25	4.25	8.50	12.5	0.56	0.406	2.00	2.10	2.81	10.56	11.10	10.5	11.70	
288AT	655.0	5.36	0.500	0.25	2.50	13.88	15.66	-	33.74	7.00	5.50	11.0	14.0	0.69	0.531	2.50	2.00	3.91	-	14.68	-	15.25	
328AT	920.0	9.67	0.500	0.25	3.00	15.88	17.96	-	35.88	8.00	6.25	12.5	16.0	0.75	0.656	3.00	2.34	4.41	-	16.68	-	17.25	
407AT	1550	35.5	0.625	0.31	4.00	20.00	20.00	-	43.12	10.0	8.00	16.0	18.0	0.86	0.938	4.00	2.38	5.44	-	20.76	-	21.56	
409AT	1850	43.8	0.625	0.31	4.00	20.00	24.00	-	47.62	10.0	8.00	16.0	22.0	0.86	0.938	4.00	2.38	5.44	-	20.76	-	21.56	

Frame	DIMENSIONS IN INCHES																
	□ U	Δ V	W	N-W	BA	BS	AA	AB	AC	AF	XL	XN	XP	ZA	ZB	ZC	
188AT	1.125	2.26	0.12	2.26	2.74	1.960	1.00	8.940	6.780	3.60	-	3.50	10.88	2.12	1.62	7.600	
189AT	1.125	2.26	0.12	2.26	2.74	1.960	1.00	8.940	6.780	3.60	-	3.50	10.88	2.62	1.62	9.600	
2110AT	1.375	2.50	0.06	2.75	3.50	3.250	1.25	10.50	8.120	4.25	5.32	4.28	12.80	3.50	2.16	11.50	
288AT	1.875	3.50	0.16	3.75	4.75	3.000	2.00	13.75	10.12	5.25	6.82	5.75	16.12	-	-	13.88	
328AT	2.125	4.00	0.16	4.25	5.25	3.125	2.00	14.75	11.12	5.25	6.82	5.75	16.50	-	-	14.88	
407AT	2.625	5.25	0.19	5.25	6.62	17.56	3.00	20.22	15.52	4.69	9.38	9.38	-	-	-	3.090	
409AT	2.625	5.25	0.19	5.25	6.62	22.06	3.00	20.22	15.52	4.69	9.38	9.38	-	-	-	3.090	

‡ Dimensions "D" will not be exceeded. When exact dimension is required, shims up to .03 inches may be necessary where dimension "D" is 8 inches or less. When dimension "D" is over 8 inches, shims up to .06 inch may be necessary.

Δ "V" represents minimum length of shaft available for hubs.

□ Shaft diameters 1.5 inches and smaller will come within the limits of +0.0000 inch -0.0005 inch. Diameters larger than 1.5 inches will come within the limits of +0.0000 inch -0.0010 inch. Shaft runout on diameters 1.625 inches and smaller shall not exceed .002 inch indicator reading. Diameters larger than 1.625 inches shall not exceed .003 inch indicator reading.

⋄ For shipping weight add 15% to net weight.

Conduit box will be assembled on the right hand side facing the commutator end for motors, and on the left hand side facing the commutator end for generators. Conduit box will be assembled on opposite side of frame, if so specified. Conduit box may be oriented to accommodate customers' application. Dimensions pertaining to conduit boxes vary according to rating.

Explosionproof C-Face

Frames 188AT to 189AT with Feet

Type CD

DIMENSIONS - For ESTIMATING ONLY unless endorsed for construction

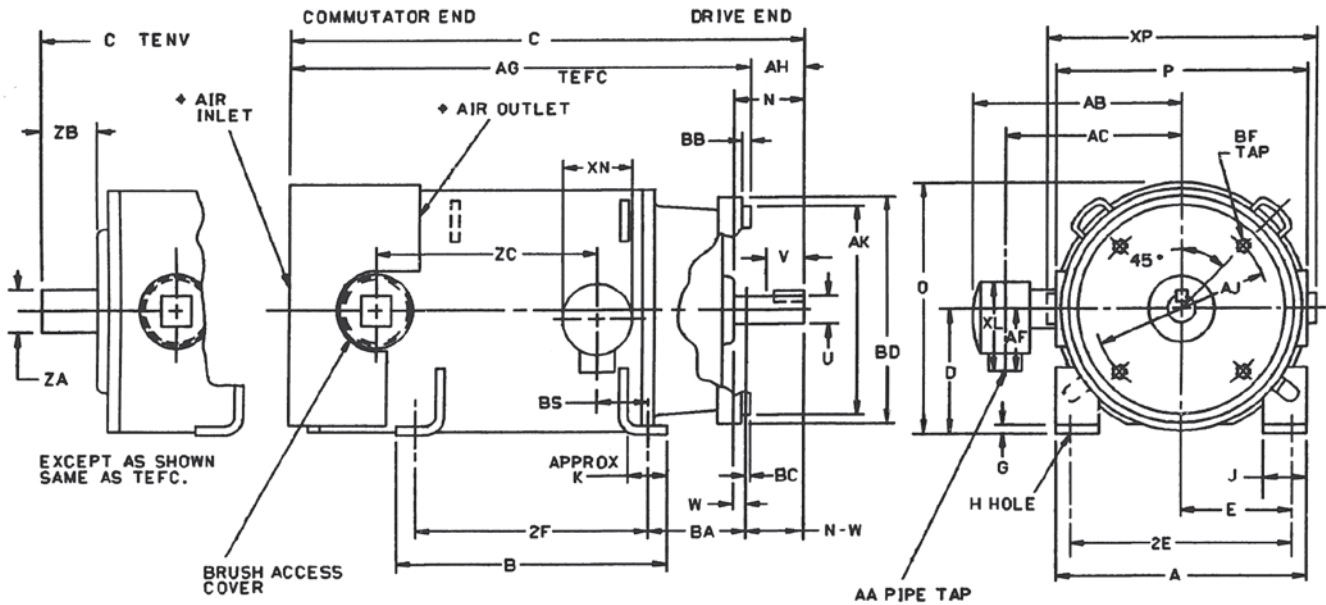

FIGURE 1

Frame	Approx. Net Wt. In Lb. ♦	Approx. WK ² of Arm Lb. Ft. ²	Key		DIMENSIONS IN INCHES																												
			Width	Depth	Lgth. ±.03	Class I, Group D															Class II, Group E, F and G												
						A	B	TENV C	TEFC C	‡ D	E	2E	2F	G	H	J	K	N	TENV O	TEFC O	TENV P	TEFC P	□ U	Δ V	W	N-W	BA	Δ V	W	N-W	BA	AA	AB
Fig 1																																	
188ATC	160	0.45	0.25	0.125	1.38	9	10.5	19.76	-	4.5	3.75	7.5	9	0.56	0.4062	2	1.62	2.38	9	-	9	-	1.125	2.26	0.13	2.25	2.75	1.62	0.5	1.88	3.12	1	8.94
189ATC	190	0.67	0.25	0.125	1.38	9	11.5	21.76	21.82	4.5	3.75	7.5	10	0.56	0.4062	2	1.62	2.38	9	9.52	9	10	1.125	2.26	0.13	2.25	2.75	1.62	0.5	1.88	3.12	1	8.94
Fig 2																																	
188ATC	160	0.45	0.188	0.094	1.38	9	10.5	19.76	-	4.5	3.75	7.5	9	0.56	0.4062	2	1.62	2.38	9	-	9	-	0.875	1.62	0.5	1.88	3.12	1.62	0.5	1.88	3.12	1	8.94
189ATC	190	0.67	0.188	0.094	1.38	9	11.5	21.76	21.82	4.5	3.75	7.5	10	0.56	0.4062	2	1.62	2.38	9	9.52	9	10	0.875	1.62	0.5	1.88	3.12	1.62	0.5	1.88	3.12	1	8.94

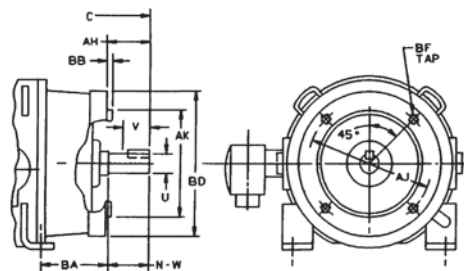

FIGURE 2

Frame Cont'd	DIMENSIONS IN INCHES																				
	AC	AF	AG TENV	AG TEFC	AH	AJ	AK	BB	BC	BD Max	BF			BS	XL	XN	XP	ZA	ZB	ZC	
											Tap	No.	Depth								
Fig 1																					
188ATC	6.78	3.6	17.64	-	2.12	7.25	8.5	0.3	0.13	8.78	.50-13	4	0.75	1.96	4.5	3.5	10.88	2.62	1.88	7.6	
189ATC	6.78	3.6	19.64	19.7	2.12	7.25	8.5	0.3	0.13	8.78	.50-13	4	0.75	1.96	4.5	3.5	10.88	2.62	1.88	9.6	
Fig 2																					
188ATC	6.78	3.6	17.64	-	2.12	5.875	4.5	0.13	-	7.14	.375-16	4	0.75	1.96	4.5	3.5	10.88	2.62	1.88	7.6	
189ATC	6.78	3.6	19.64	19.7	2.12	5.875	4.5	0.13	-	7.14	.375-16	4	0.75	1.96	4.5	3.5	10.88	2.62	1.88	9.6	

- ‡ Dimensions "D" will not be exceeded. When exact dimension is required, shims up to .03 inches may be necessary where dimension "D" is 8 inches or less. When dimension "D" is over 8 inches, shims up to .06 inch may be necessary.
- Δ "V" represents minimum length of shaft available for hubs.
- Shaft diameters 1.5 inches and smaller will come within the limits of +0.0000 inch -0.0005 inch. Diameters larger than 1.5 inches will come within the limits of +0.0000 inch -0.0010 inch. Shaft runout on diameters 1.625 inches and smaller shall not exceed .002 inch indicator reading. Diameters larger than 1.625 inches shall not exceed .003 inch indicator reading.
- ♦ For shipping weight add 15% to net weight.

Conduit box will be assembled on the right hand side facing the commutator end for motors, and on the left hand side facing the commutator end for generators. Conduit box will be assembled on opposite side of frame, if so specified. Conduit box may be oriented to accommodate customers' application. Dimensions pertaining to conduit boxes vary according to rating.

From 36C697570AA

DIMENSIONS - For ESTIMATING ONLY unless endorsed for construction

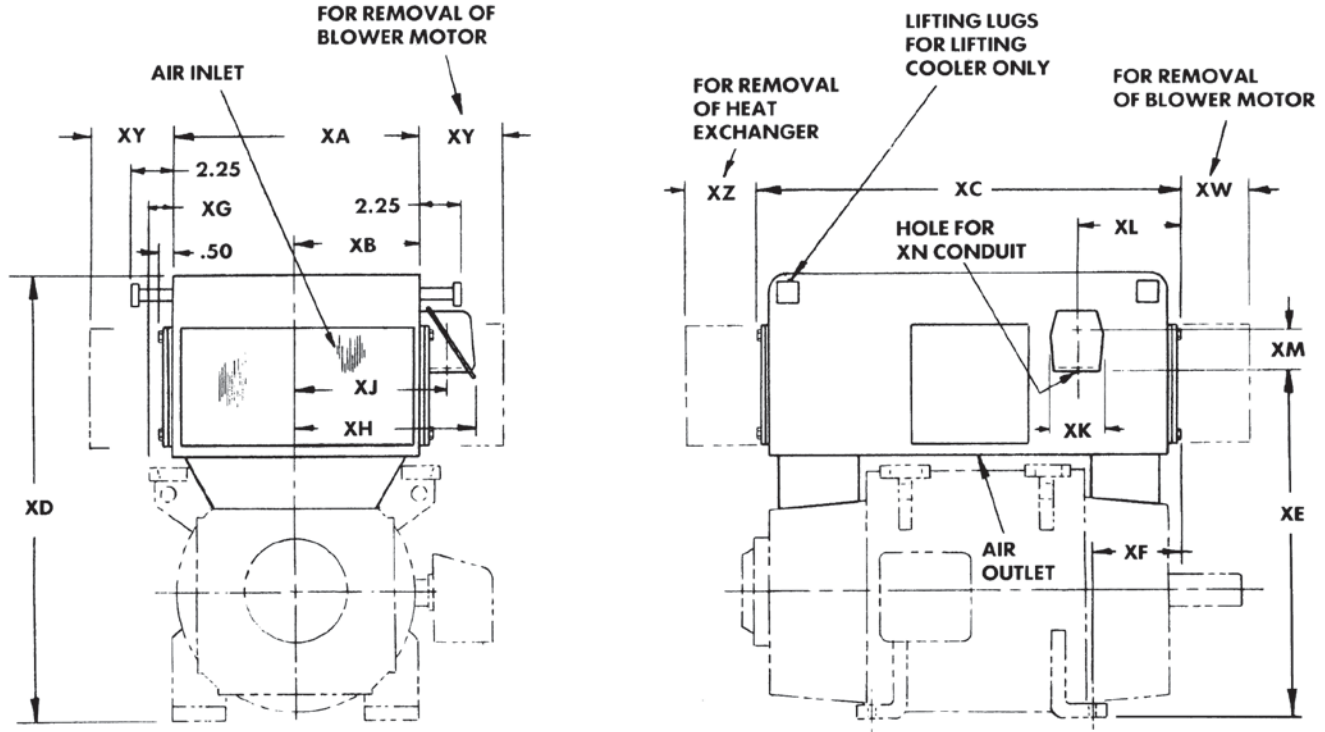

Frame	Cooler Type	Cooler Weight in Lb.	XA	XB	XC	XD	XE	XF	XG	XH	XJ	XK	XL	XM	XN	XW	XY	XZ
CD366AT	Z	230	20.24	10.12	31.44	33.70	27.30	6.29	0.88	12.92	11.70	3.44	6.60	2.5	1.25	8.740	18.75	10.38
CD368AT	Z	252	20.24	10.12	34.44	33.70	27.30	6.29	0.88	12.92	11.70	3.44	6.60	2.5	1.25	8.740	18.75	10.38
CD407AT	A	425	24.00	12.00	37.88	36.96	29.65	6.88	1.00	15.88	13.75	5.50	7.62	3.5	1.25	11.00	12.00	11.00
L407AT	A	425	24.00	12.00	37.88	36.96	29.65	6.88	1.00	15.88	13.75	5.50	7.62	3.5	1.25	11.00	12.00	11.00
CD409AT	A	440	24.00	12.00	42.38	36.96	29.65	6.88	1.00	15.88	13.75	5.50	7.62	3.5	1.25	11.00	12.00	11.00
L409AT	A	440	24.00	12.00	42.38	36.96	29.65	6.88	1.00	15.88	13.75	5.50	7.62	3.5	1.25	11.00	12.00	11.00
CD504AT	A	425	24.00	12.00	37.88	41.06	33.75	8.75	1.00	15.88	13.75	5.50	7.62	3.5	1.25	11.00	12.00	11.00
L504AT	A	430	24.00	12.00	39.62	41.06	33.75	8.75	1.00	15.88	13.75	5.50	7.62	3.5	1.25	11.00	12.00	11.00
CD506AT	A	435	24.00	12.00	41.88	41.06	33.75	8.75	1.00	15.88	13.75	5.50	7.62	3.5	1.25	11.00	12.00	11.00
L506AT	A	445	24.00	12.00	43.62	41.06	33.75	8.75	1.00	15.88	13.75	5.50	7.62	3.5	1.25	11.00	12.00	11.00
CD508AT	A	460	24.00	12.00	46.88	41.06	33.75	8.75	1.00	15.88	13.75	5.50	7.62	3.5	1.25	11.00	12.00	11.00
L508AT	A	470	24.00	12.00	48.62	41.06	33.75	8.75	1.00	15.88	13.75	5.50	7.62	3.5	1.25	11.00	12.00	11.00
CD504AT	B	610	30.62	15.31	43.50	47.88	38.50	8.53	1.18	19.12	17.19	5.50	8.75	3.5	1.25	13.25	15.00	13.50
L504AT	B	610	30.62	15.31	43.50	47.88	38.50	8.53	1.18	19.12	17.19	5.50	8.75	3.5	1.25	13.25	15.00	13.50
CD506AT	B	610	30.62	15.31	43.50	47.88	38.50	8.53	1.18	19.12	17.19	5.50	8.75	3.5	1.25	13.25	15.00	13.50
L506AT	B	625	30.62	15.31	45.25	47.88	38.50	8.53	1.18	19.12	17.19	5.50	8.75	3.5	1.25	13.25	15.00	13.50
CD508AT	B	660	30.62	15.31	48.50	47.88	38.50	8.53	1.18	19.12	17.19	5.50	8.75	3.5	1.25	13.25	15.00	13.50
L508AT	B	675	30.62	15.31	50.25	47.88	38.50	8.53	1.18	19.12	17.19	5.50	8.75	3.5	1.25	13.25	15.00	13.50

Standard location of cooler conduit box is on the same side as machine conduit box, however, box will be located on opposite side if specified.
Providing mounting conditions permit, conduit box may be turned so that entrance can be made upward, downward, or horizontally.

Outline Dimensions

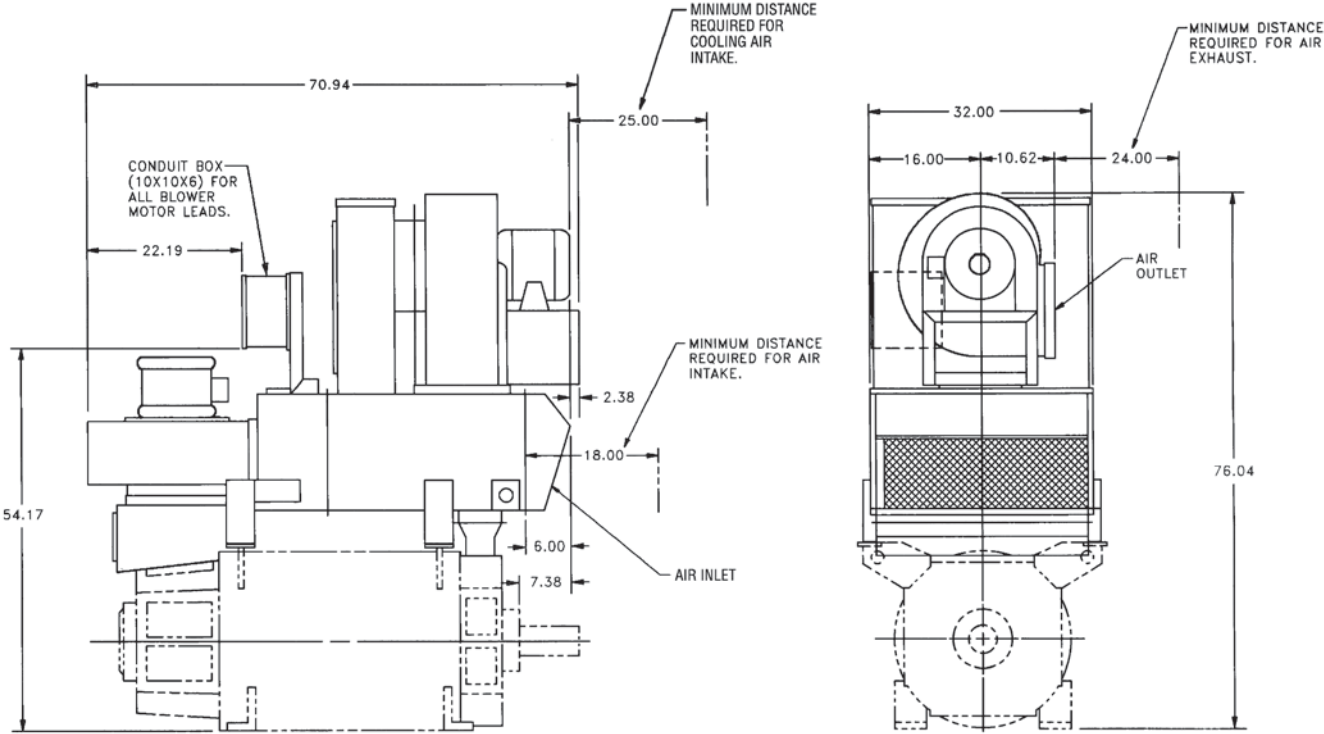

Approximate cooler weight
Aluminum 950 lbs
Stainless Steel 1209 lbs

Outline Dimensions

DIMENSIONS - For ESTIMATING ONLY unless endorsed for construction

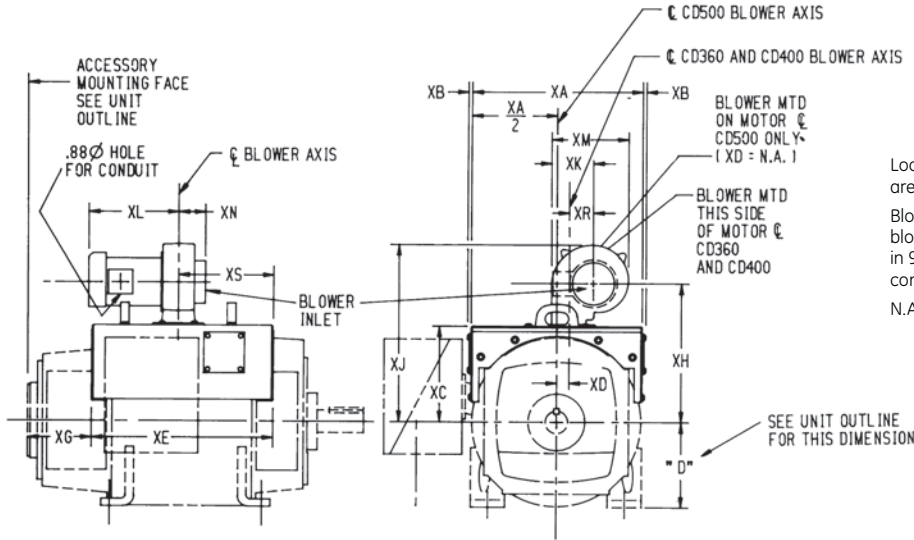

TOP MOUNTED BLOWER

Locations of Blowers shown are preferred locations
Blower can be rotated about blower axis to any position in 90° increments where conditions permit.
N.A. = Not Applicable

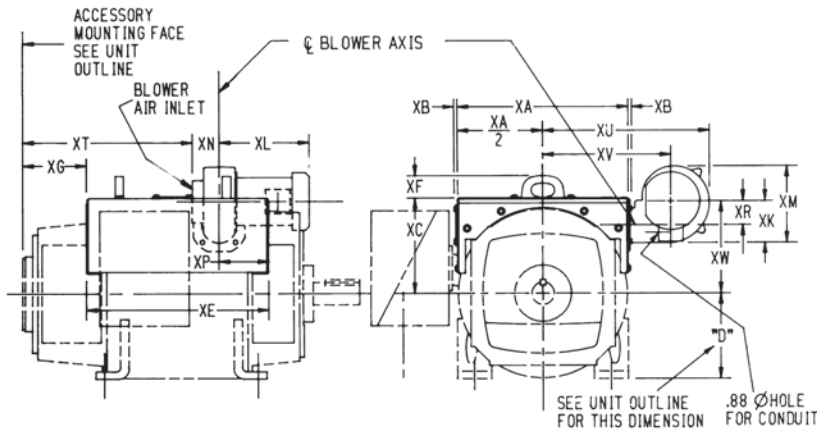

SIDE MOUNTED BLOWER

Locations of Blowers shown are preferred locations
Blower can be rotated about blower axis to any position in 90° increments where conditions permit.
N.A. = Not Applicable

Outline Dimensions

Frame	Approx. Net Wt. in Lb.	DIMENSIONS IN INCHES																			
		XA	XB	XC	XD	XE	XF	XG	XH	XJ	XK	XL	XM	XN	XP	XR	XS	XT	XU	XV	XW
CD327AT	33	16.40	0.32	9.260	2.68	17.98	1.56	6.250	14.52	19.08	4.88	10.38	8.880	3.15	5.630	2.81	10.72	15.45	17.65	13.09	9.070
CD328AT	60	16.40	0.32	9.260	2.68	19.86	1.56	6.250	14.52	19.08	4.88	10.38	8.880	3.15	7.050	2.81	12.59	15.90	17.65	13.09	9.070
CD365AT	54	18.40	0.42	10.22	1.45	16.11	2.61	7.480	15.23	19.73	4.90	10.51	8.780	3.38	5.860	2.82	7.780	14.46	17.98	14.23	9.840
CD366AT	56	18.40	0.42	10.22	1.45	18.42	2.61	7.480	15.23	19.73	4.90	10.51	8.780	3.38	5.860	2.82	8.880	16.66	17.98	14.23	9.840
CD368AT	59	18.40	0.42	10.22	1.45	21.42	2.61	7.480	15.23	19.73	4.90	10.51	8.780	3.38	5.860	2.82	10.38	19.66	17.98	14.23	9.840
CD407AT	60	20.00	0.42	11.22	1.45	21.42	2.61	7.380	15.23	20.73	4.90	10.51	8.780	3.38	5.810	2.82	11.24	19.61	19.51	15.01	10.84
CDL407AT	60	20.00	0.42	11.22	1.45	21.42	2.61	10.78	16.23	20.73	4.90	10.51	8.780	3.38	5.810	2.82	11.24	23.01	19.51	15.01	10.84
CD409AT	70	20.00	0.42	11.22	1.45	25.92	2.61	7.380	16.23	20.73	4.90	10.51	8.780	3.38	5.810	2.82	13.49	24.11	19.51	15.01	10.84
CDL409AT	70	20.00	0.42	11.22	1.45	25.92	2.61	10.78	16.23	20.73	4.90	10.51	8.780	3.38	5.810	2.82	13.49	27.51	19.51	15.01	10.84
CD504AT	75	25.24	0.45	13.73	N.A.	21.29	2.60	11.20	20.04	28.47	8.53	11.85	14.91	4.37	4.820	5.57	11.02	23.30	27.36	19.93	13.93
CD506AT	84	25.24	0.45	13.73	N.A.	25.29	2.60	11.39	20.04	28.47	8.53	11.85	14.91	4.37	8.820	5.57	15.02	23.49	27.36	19.93	13.93
CD508AT	89	25.24	0.45	13.73	N.A.	30.29	2.60	11.39	20.04	28.47	8.53	11.85	14.91	4.37	13.82	5.57	20.02	23.49	27.36	19.93	13.93
CDL508AT	92	25.24	0.45	13.73	N.A.	32.05	2.60	11.39	20.04	28.47	8.53	11.85	14.91	4.37	13.82	5.57	20.02	25.25	27.36	19.93	13.93

From 36C697331AA

Dimensions, Air Openings

Frames 210AT to 5010AY

Type CD

DIMENSIONS - For ESTIMATING ONLY unless endorsed for construction

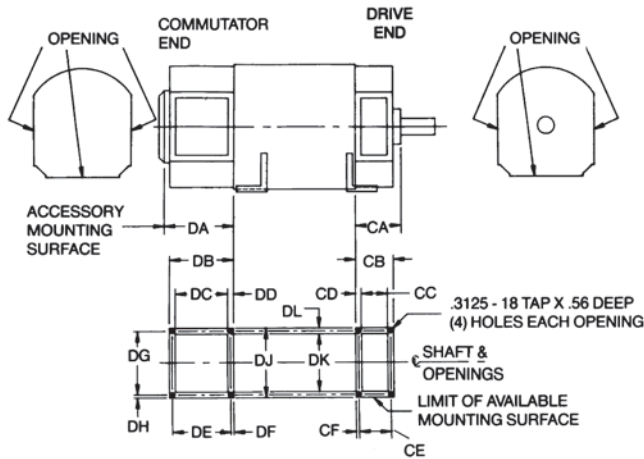

FIGURE 1

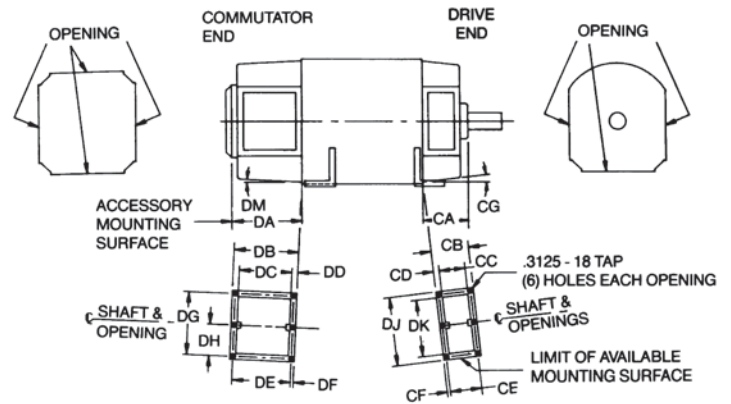

FIGURE 2

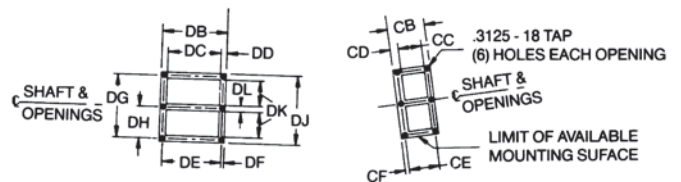

FIGURE 3

Outline Dimensions

Frame	Figure No.	DIMENSIONS IN INCHES																	
		CA	CB	CC	CD	CE	CF	CG	DA	DB	DC	DD	DE	DF	DG	DJ	DK	DL	DM
CD210AT	1	4.59	3.24	2.38	0.50	2.62	0.34	-	6.710	5.400	4.20	0.50	4.42	0.34	5.00	5.640	4.42	0.61	-
CD258AT CD259AT	1	5.03	3.52	2.38	0.48	2.62	0.34	-	6.610	5.140	4.20	0.48	4.42	0.34	6.00	6.760	5.42	0.67	-
CD287AT CD288AT	1	5.53	3.94	2.88	0.58	3.32	0.34	-	8.210	6.440	5.00	0.68	5.50	0.40	7.00	7.760	6.22	0.77	-
CD320AT	1	5.85	4.12	2.88	0.58	3.32	0.34	-	7.950	6.300	5.00	0.68	5.50	0.40	8.00	8.760	7.22	0.77	-
CD360AT	2	6.30	4.80	3.06	0.81	3.70	0.56	4	9.600	7.860	5.44	0.76	5.80	0.62	10.4	11.30	9.24		2◇
CD400AT	3	6.98	5.22	3.19	0.77	3.70	0.46	5	9.120	7.240	5.44	0.72	5.80	0.56	10.4	12.74	4.62	0.78	5◇
CDL400AT	3	6.98	5.22	3.19	0.77	3.70	0.46	5	12.52	10.64	7.74	0.72	8.20	0.56	10.4	12.74	4.62	0.78	4◇
CD500AT CDL500AT	3	8.18	5.96	4.26	0.94	5.00	0.54	8	13.48	11.42	9.36	0.86	9.80	0.64	12.8	14.70	5.14	0.88	4◇
CD5010AY	3	8.40	5.90	4.26	0.82	5.00	0.44	0	13.48	11.42	9.36	0.86	9.80	0.64	12.8	14.70	5.14	0.88	4◇

◇ For shipping weight add 15% to net weight.

From 533C118AA

Blower Unit, Commutator End Mounted

Frames CD180AT to CD280AT

Type CD

DIMENSIONS - For ESTIMATING ONLY unless endorsed for construction

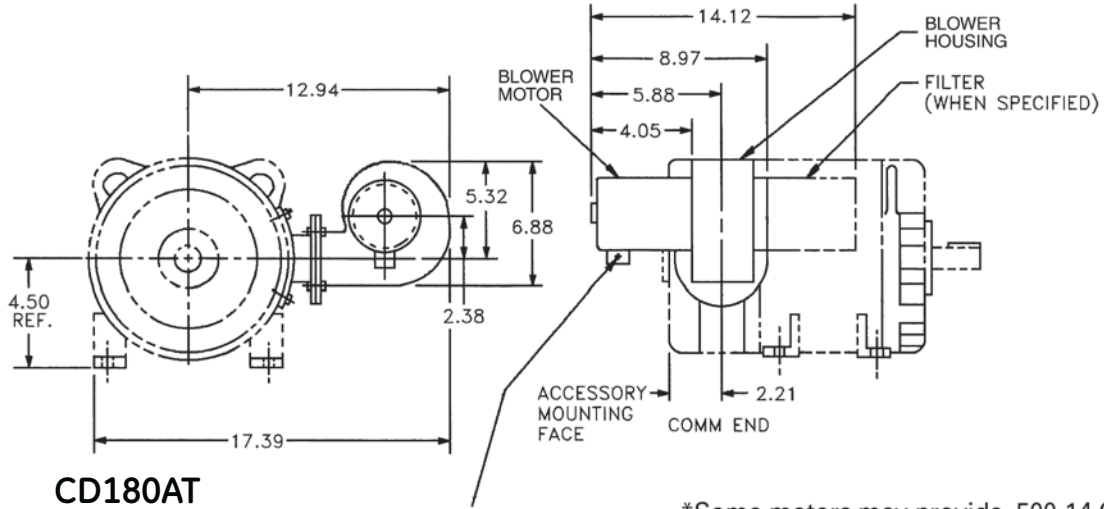

CD180AT

*.875 DIAMETER HOLE
(BLOWER MOTOR CONDUIT BOX)

*Some motors may provide .500-14 Conduit
Thread in frame in place of Conduit Box.

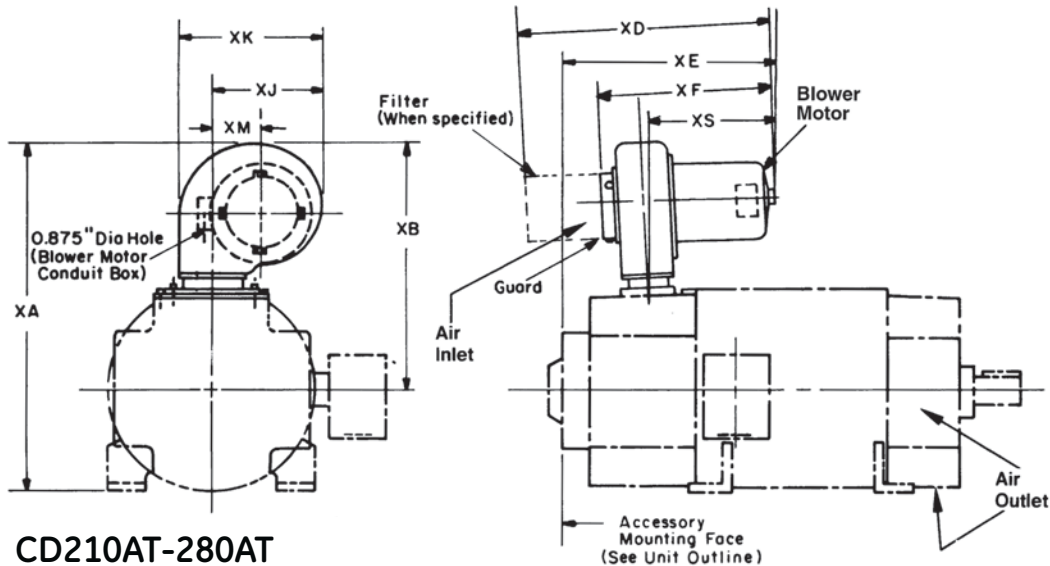

CD210AT-280AT

Type CD Frame	Approx. Net Wt. in Lb.	DIMENSIONS IN INCHES								
		XA	XB	XD	XE	XF	XJ	XK	XM	XS
210AT*	20	17.61	12.36	14.62	10.76	9.520	5.32	6.88	2.38	6.680
250AT*	20	19.61	13.36	14.62	10.66	9.520	5.32	6.88	2.38	6.680
280AT	28	23.10	16.10	21.82	15.34	13.53	6.82	6.88	2.81	10.38

* On CD210AT & CD250AT frames, when sidemounted, blower can only be mounted opposite conduit box.

NOTE: The required air flow is obtained only when the blower motors are operated in the correct direction of rotation. When facing the air inlet, the blower wheel should rotate counterclockwise. Check the blower motor for correct direction of rotation by running it in both directions and observing the quantity of air discharged. The direction of rotation which gives the greatest air flow is the correct one. Blower motors can be reversed by interchanging the external connections to any two of the three line leads.

Outline Dimensions

Blower Unit, Commutator End Mounted

Frames 320AT

Type CD

DIMENSIONS - For ESTIMATING ONLY unless endorsed for construction

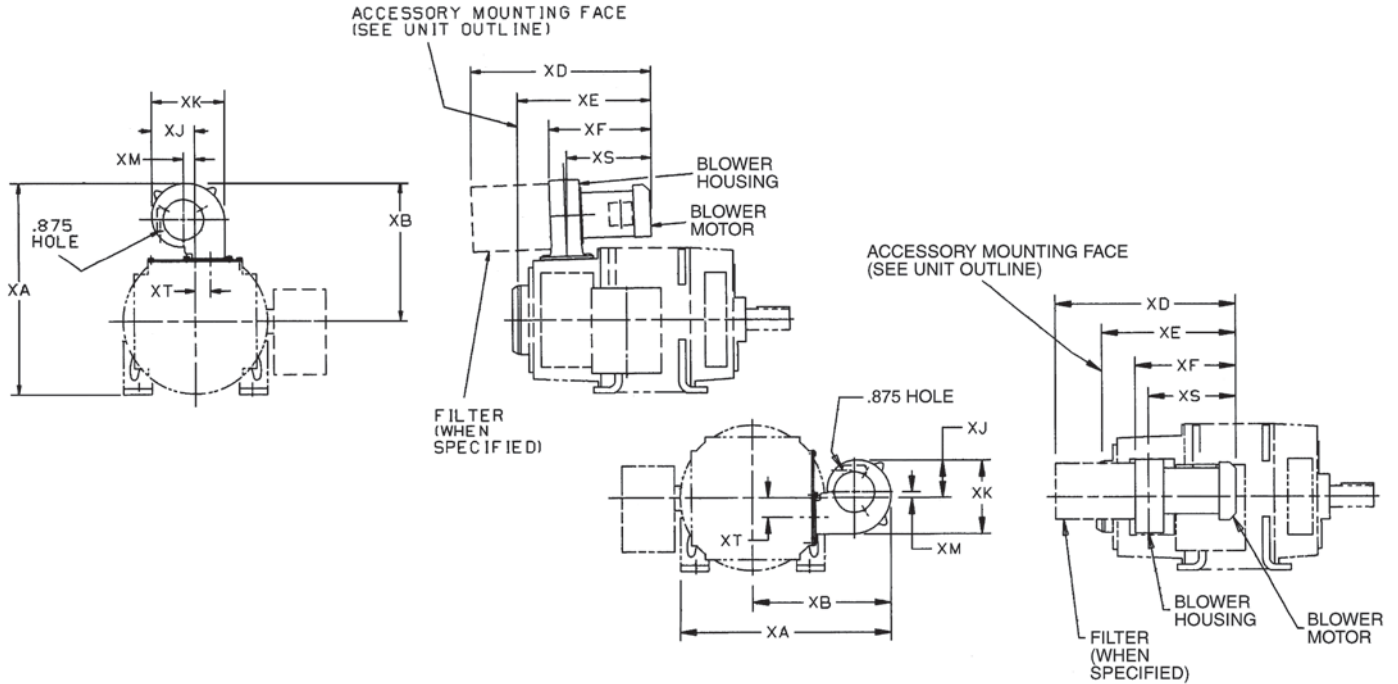

Type CD Frame	Approx. Net Wt. in Lb.	DIMENSIONS IN INCHES									
		XA	XB	XD	XE	XF	XJ	XK	XM	XS	XT
320AT	61	27.87	19.87	22.94	16.95	14.75	10.2	13.38	4.49	12.17	0.53

Outline Dimensions

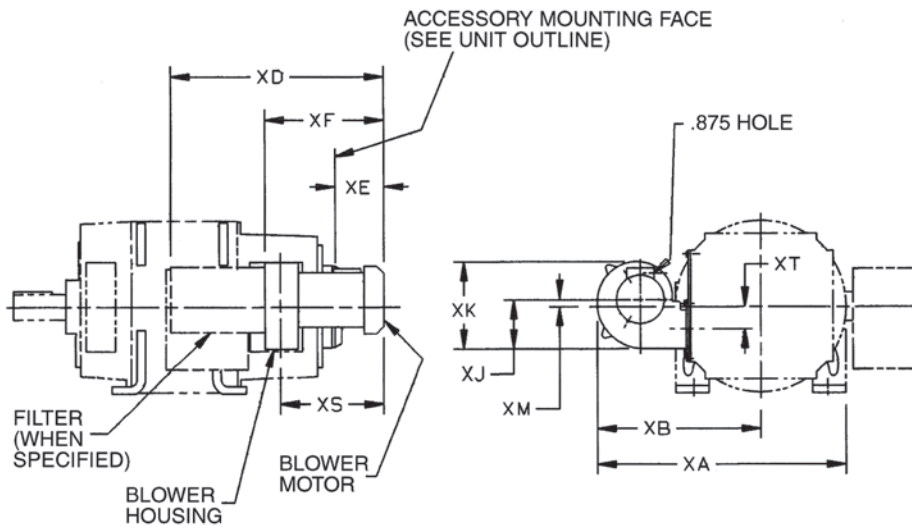

Type CD Frame	Approx. Net Wt. in Lb.	DIMENSIONS IN INCHES									
		XA	XB	XD	XE	XF	XJ	XK	XM	XS	XT
320AT	65	27.81	19.87	22.94	7.39	14.75	10.2	13.38	4.49	12.17	0.53

NOTE: The required air flow is obtained only when the blower motors are operated in the correct direction of rotation. When facing the air inlet, the blower wheel should rotate counterclockwise. Check the blower motor for correct direction of rotation by

running it in both directions and observing the quantity of air discharged. The direction of rotation which gives the greatest air flow is the correct one. Blower motors can be reversed by interchanging the external connections to any two of the three line leads.

36A167799HN, 36A167799HS, 36A167799HT

Blower Unit, Commutator End Mounted

Frames 360AT to 400AT

Type CD

DIMENSIONS - For ESTIMATING ONLY unless endorsed for construction

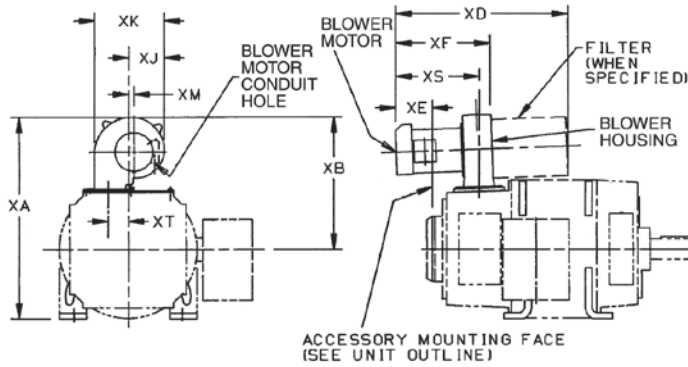

FIGURE 1 TOP MOUNTED

Type CD Frame	Approx. Net Wt. in Lb.	DIMENSIONS IN INCHES				
		XA	XB	XD	XE Fig. 1	XE Fig. 2
CD360AT	65	28.80	19.80	23.06	18.13	6.51
CD400AT	65	30.52	20.52	23.19	17.69	7.09
CDL400AT	70	30.52	20.52	23.19	19.87	4.91

Type CD Frame	DIMENSIONS IN INCHES					
	XJ	XK	XM	XS	XT	XF
CD360AT	8.93	13.38	3.22	12.09	1.8	14.90
CD400AT	8.93	13.38	3.22	12.04	1.8	15.07
CDL400AT	8.93	13.38	3.22	12.03	1.8	15.07

Frame	Blower Motor Conduit Hole
CD360AT	.875 Diameter Hole in Blower Motor CND Box
CD400AT	

From 36A167799HM

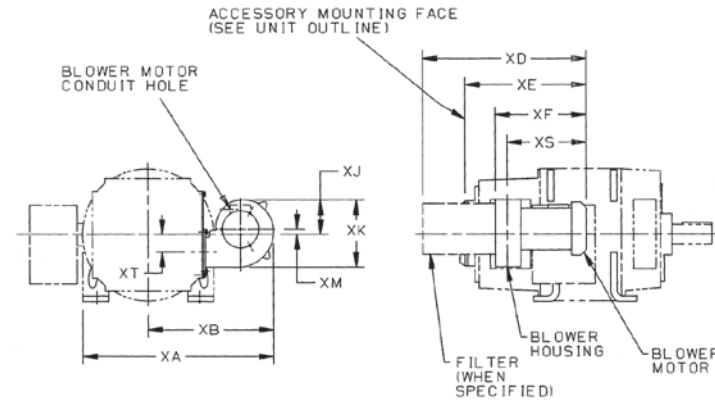

FIGURE 2 SIDE MOUNTED
RIGHT HAND SIDE
FACING COMMUTATOR END

From 36A167799HP

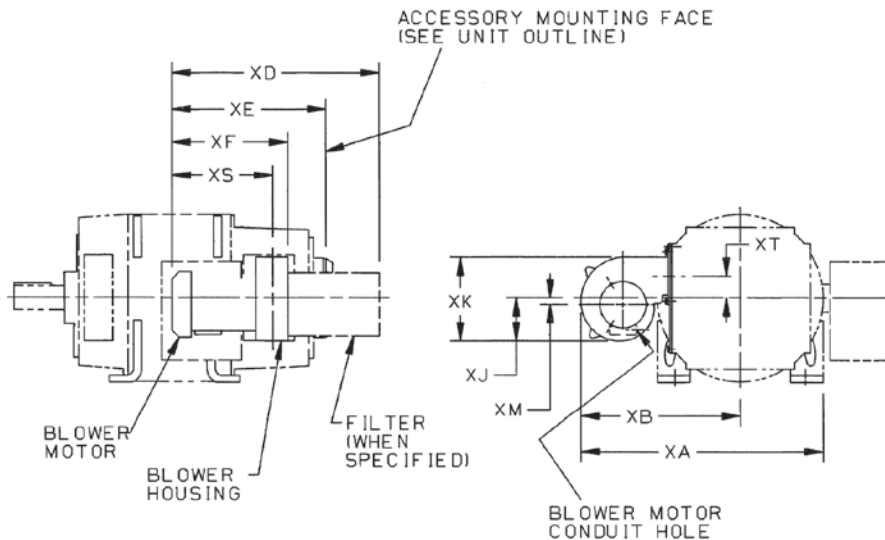

FIGURE 3 SIDE MOUNTED
LEFT HAND SIDE
FACING COMMUTATOR END

From 36A167799HR

Outline Dimensions

Blower Unit, Commutator End Mounted

Frames 500AT

Type CD

DIMENSIONS - For ESTIMATING ONLY unless endorsed for construction

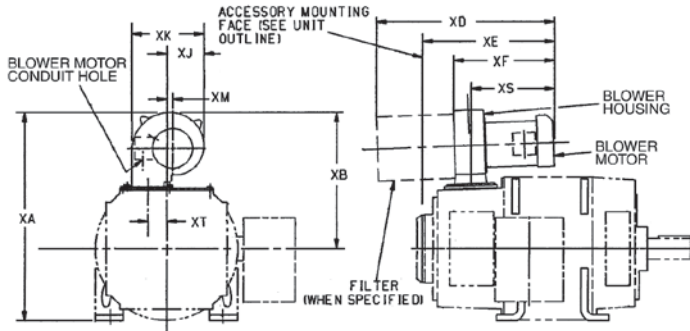

Type CD Frame	Approx. Net Wt. in Lb.	DIMENSIONS IN INCHES				
		XA	XB	XD	XE Fig. 1	XE Fig. 2
CD500AT	83	43.05	30.55	32.58	22.95	8.35

Type CD Frame	DIMENSIONS IN INCHES					
	XJ	XK	XM	XS	XT	XF
CD500AT	15.17	20.36	6.47	15.65	1.25	20.43

Frame	Blower Motor Conduit Hole
CD500AT	1.09" Diameter Hole in Blower Motor CND Box

From 36A167799GK

FIGURE 1 TOP MOUNTED

NOTE: The required air flow is obtained only when the blower motors are operated in the correct direction of rotation. When facing the air inlet, the blower wheel should rotate counterclockwise. Check the blower motor for correct direction of rotation by running it in both directions and observing the quality of air discharged. The direction of rotation which gives the greatest air flow is the correct one. Blower motors can be reversed by interchanging the external connections to any two of three line leads.

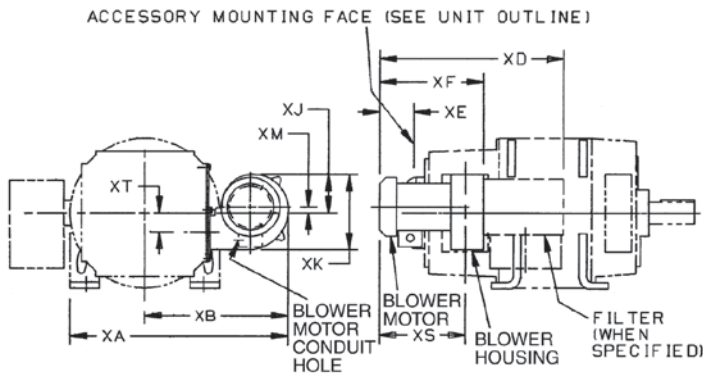

From 36A167799GN

FIGURE 2 SIDE MOUNTED
RIGHT HAND SIDE
FACING COMMUTATOR END

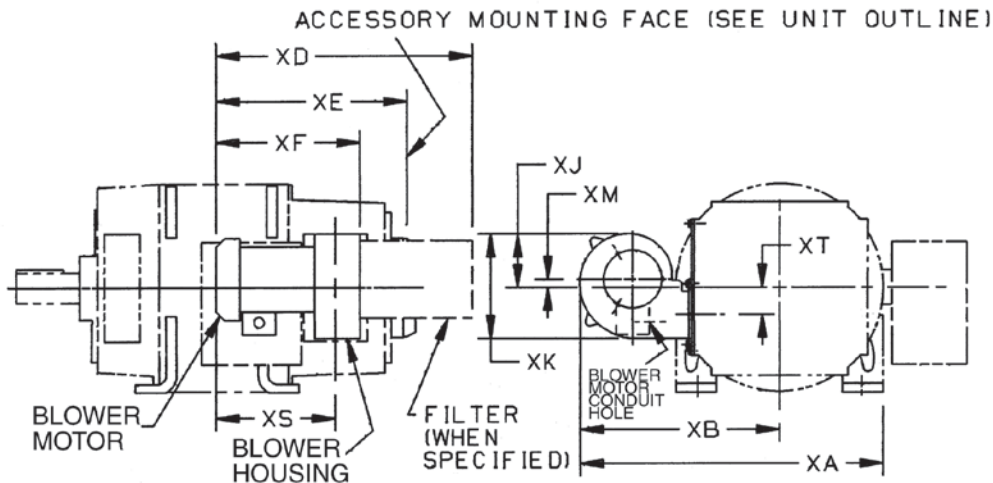

From 36A167799GL

FIGURE 3 SIDE MOUNTED
LEFT HAND SIDE
FACING COMMUTATOR END

DIMENSIONS - For ESTIMATING ONLY unless endorsed for construction

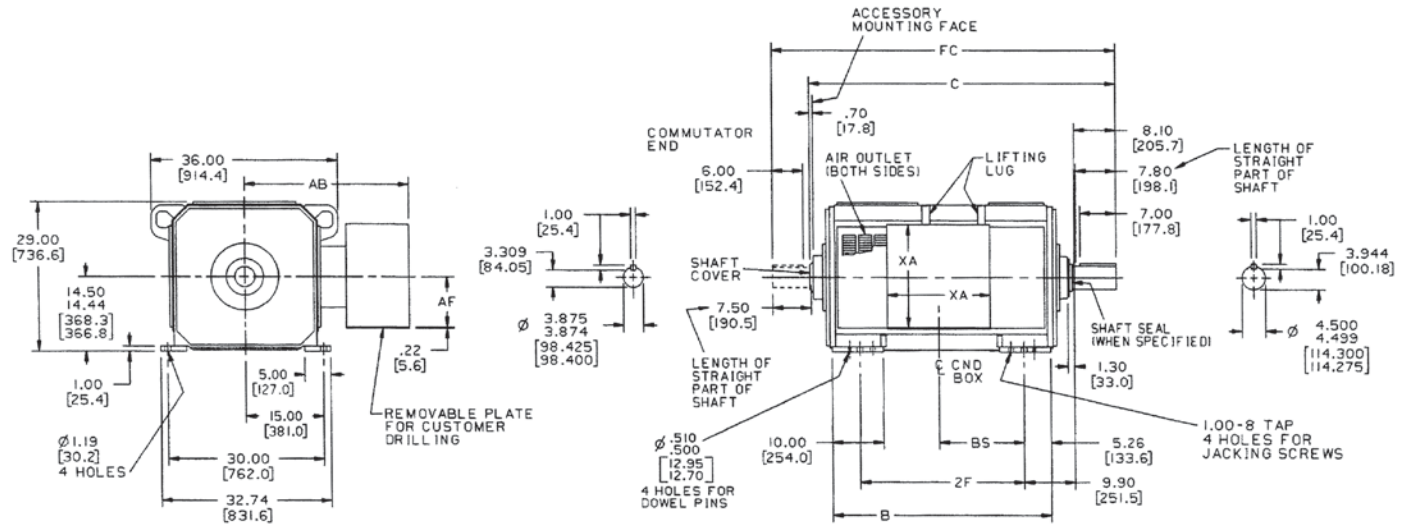

Frame	Approx. Net Wt. in Lb. ⚡	Approx. Wk ² of Armature Ft. Lb.	B	2F	C	FC	BS	
							Standard Box	Overize Box
CD6050	3900	160	42.7	32	59.71	66.96	16.59	14.59
CD6052	4200	180	44.8	36	61.81	69.06	18.69	16.69
CD6054	4100	170	47.0	36	64.01	71.26	14.59	13.59
CD6055	4700	210	47.4	36	64.41	71.66	21.29	19.29
CD6057	4500	190	49.1	40	66.11	73.36	16.69	15.69
CD6058	5300	240	50.6	40	67.61	74.86	24.49	22.49
CD6059	5000	220	51.7	40	68.71	75.96	19.29	18.29
CD6062	6000	280	54.6	45	71.61	78.86	28.49	26.49
CD6063	5600	250	54.9	45	71.91	79.16	22.49	21.49
CD6066	6300	290	58.9	50	75.91	83.16	26.49	25.49

CONDUIT BOX DIMENSIONS				
Frame	Box	AB	AF	XA
CD6050	Standard	31.72	10	20
CD5052				
CD6055	Overize	35.75	12	24
CD6058				
CD6062				
CD6054	Standard	35.72	12	24
CD6057				
CD6059	Overize	39.72	13	26
CD6063				
CD6066				

Accessory mounting face dimensions, see page 4.49.
 Commutator end shaft extension is furnished only when specifically ordered.
 Standard conduit box location is right hand side for motor and left hand side for generator facing commutator end. Conduit box can be assembled on the oppo site side of frame, or assembled so that entrance can be made from above, from commutator end, or from drive end if so specified. Fixed termination is provided for customer connections.

Splashproof machines will have additional covers, but all dimensions will remain the same.
 Air inlet can be provided at drive end at top, bottom, or either side if so specified.
 Totally enclosed separately ventilated enclosures can be provided with both air inlet and outlet at top, bottom, or either side.
 ⚡ For shipping weight, add 15% to net weight.

Outline Dimensions

DIMENSIONS - For ESTIMATING ONLY unless endorsed for construction

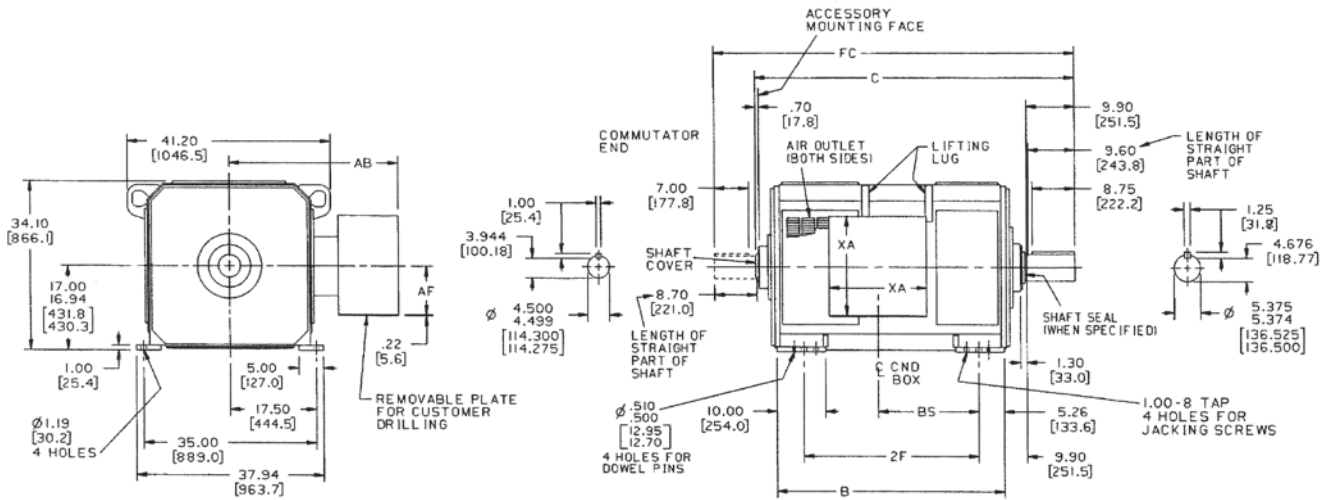

Frame	Approx. Net Wt. in Lb. ⚡	Approx. Wk ² of Armature Ft. Lb.	B	2F	C	FC	BS	
							Standard Box	Oversize Box
CD6154	5800	390	46.8	36	65.61	74.06	20.79	18.79
CD6157	6500	440	49.4	40	68.21	76.66	23.39	21.39
CD6160	7300	510	52.6	42	71.41	79.86	26.59	24.59
CD6163	6300	420	55.4	45	74.21	82.66	19.79	16.79
CD6164	8300	600	56.6	45	75.41	83.86	30.59	28.59
CD6165	7000	480	58.0	48	76.81	85.26	22.39	19.39
CD6168	7800	550	61.2	50	80.01	88.46	25.59	22.59
CD6169	9500	700	61.2	50	80.01	88.46	35.19	33.19
CD6173	8800	640	65.2	56	84.01	92.46	29.59	26.59
CD6177	10000	740	69.8	60	88.61	97.06	34.19	31.19

CONDUIT BOX DIMENSIONS				
Frame	Box	AB	AF	XA
CD6154	Standard	34.32	10	20
CD6157				
CD6160	Oversize	38.32	12	24
CD6164				
CD6169				
CD6163	Standard	38.32	12	24
CD6165				
CD6168	Oversize	42.32	15	26
CD6173				
CD6177				

Outline Dimensions

Accessory mounting face dimensions, see page 4.49.
 Commutator end shaft extension is furnished only when specifically ordered.
 Standard conduit box location is right hand side for motor and left hand side for generator facing commutator end. Conduit box can be assembled on the opposite side of frame, or assembled so that entrance can be made from above, from commutator end, or from drive end if so specified. Fixed termination is provided for customer connections.

Splashproof machines will have additional covers, but all dimensions will remain the same.
 Air inlet can be provided at drive end at top, bottom, or either side if so specified.
 Totally enclosed separately ventilated enclosures can be provided with both air inlet and outlet at top, bottom, or either side.
 ⚡ For shipping weight, add 15% to net weight.

DIMENSIONS - For ESTIMATING ONLY unless endorsed for construction

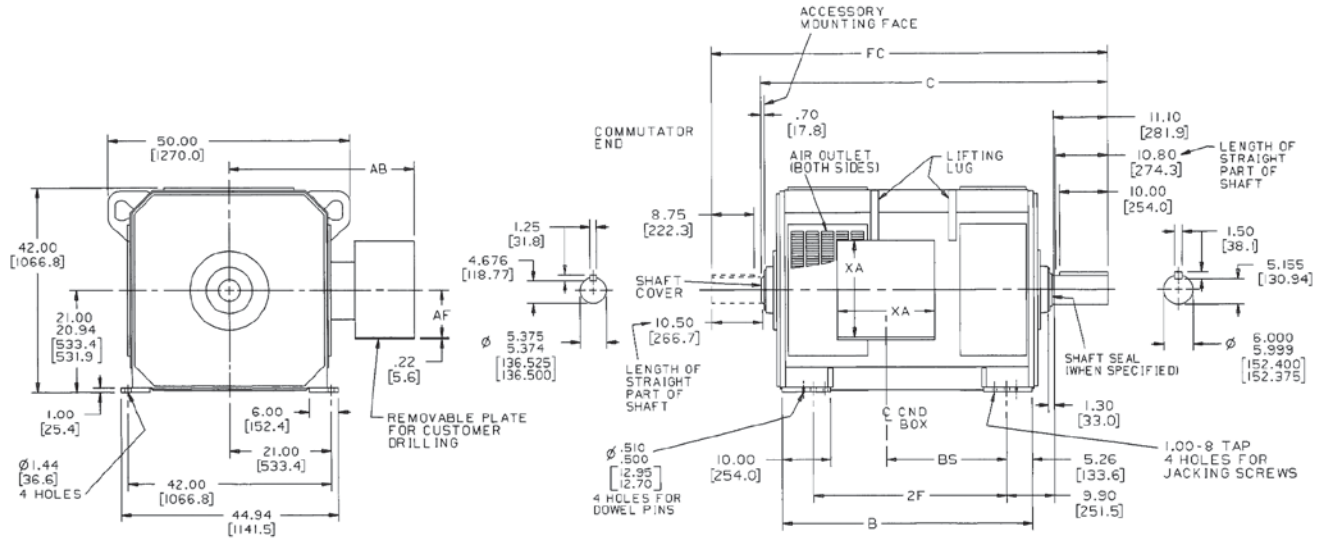

Frame	Approx. Net Wt. in Lb. ⬠	Approx. Wk ² of Armature Ft. Lb.	B	2F	C	FC	BS	
							Standard Box	Oversize Box
CD6259	9800	960	51.7	40	71.71	81.960	24.89	22.89
CD6262	11100	1120	54.9	45	74.91	85.160	28.09	26.09
CD6266	12700	1320	58.9	50	78.91	89.160	32.09	30.09
CD6268	10400	1020	60.3	50	80.31	90.560	23.89	20.89
CD6270	11700	1180	63.5	52	83.51	93.760	27.09	24.09
CD6271	14500	1550	63.5	52	83.51	93.760	36.69	34.69
CD6275	13300	1380	67.5	56	87.51	97.760	31.09	28.09
CD6280	15200	1610	72.1	63	92.11	102.36	35.69	32.69

CONDUIT BOX DIMENSIONS				
Frame	Box	AB	AF	XA
CD6259	Standard	38.22	10	20
CD6262				
CD6266	Oversize	42.22	12	24
CD6271				
CD6268	Standard	42.22	12	24
CD6270				
CD6275	Oversize	46.22	15	30
CD6280				

Accessory mounting face dimensions, see page 4.49.
Commutator end shaft extension is furnished only when specifically ordered.
Standard conduit box location is right hand side for motor and left hand side for generator facing commutator end. Conduit box can be assembled on the opposite side of frame, or assembled so that entrance can be made from above, from commutator end, or from drive end if so specified. Fixed termination is provided for customer connections.

Splashproof machines will have additional covers, but all dimensions will remain the same.
Air inlet can be provided at drive end at top, bottom, or either side if so specified.
Totally enclosed separately ventilated enclosures can be provided with both air inlet and outlet at top, bottom, or either side.
⬠ For shipping weight, add 15% to net weight.

Outline Dimensions

DIMENSIONS - For ESTIMATING ONLY unless endorsed for construction

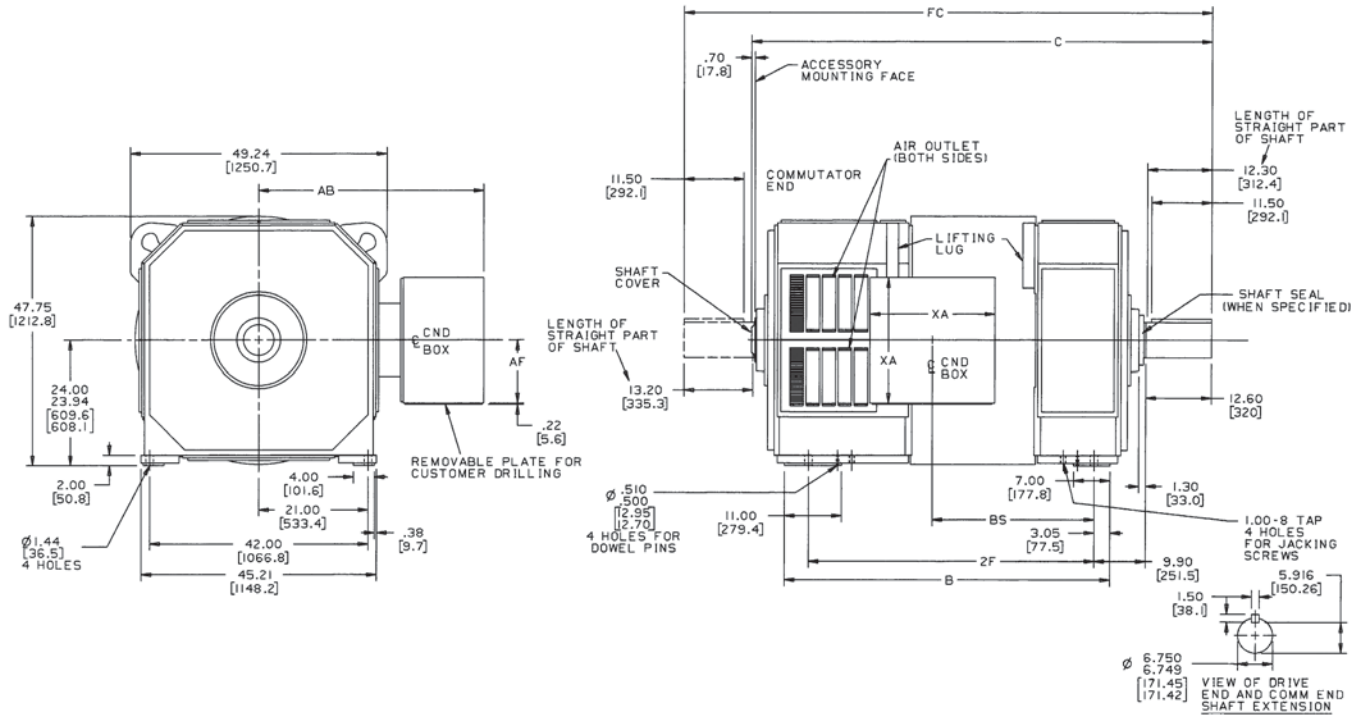

Outline Dimensions

Frame	Approx. Net Wt. in Lb. ⚡	Approx. Wk ² of Armature Ft. Lb.	B	2F	C	FC	BS	
							Standard Box	Oversize Box
CD6766	12100	1550	55.18	45	80.98	93.930	23.67	20.67
CD6770	14000	1850	58.68	50	84.48	97.430	27.17	24.17
CD6771	12400	1650	59.48	50	85.28	98.230	23.67	20.67
CD6774	15200	2200	62.68	55	88.48	101.43	31.17	28.17
CD6776	14000	1950	62.98	55	88.78	101.73	27.17	24.17
CD6778	15600	2300	66.98	60	92.78	105.73	31.17	28.17
CD6779	17200	2700	67.68	60	93.48	106.43	36.17	33.17
CD6785	17600	2750	71.98	65	97.78	110.73	36.17	33.17

CONDUIT BOX DIMENSIONS				
Frame	Box	AB	AF	XA
CD6766	Standard	43.75	12	24
CD6770				
CD6771				
CD6774				
CD6776	Oversize	47.75	15	30
CD6778				
CD6779				
CD6785				

Accessory mounting face dimensions, see page 4.49.
 Commutator end shaft extension is furnished only when specifically ordered.
 Standard conduit box location is right hand side for motor and left hand side for generator facing commutator end. Conduit box can be assembled on the opposite side of frame, or assembled so that entrance can be made from above, from commutator end, or from drive end if so specified. Fixed termination is provided for customer connections.

Splashproof machines will have additional covers, but all dimensions will remain the same.
 Air inlet can be provided at drive end at top, bottom, or either side if so specified.
 Totally enclosed separately ventilated enclosures can be provided with both air inlet and outlet at top, bottom, or either side.
 ⚡ For shipping weight, add 15% to net weight.

DIMENSIONS - For ESTIMATING ONLY unless endorsed for construction

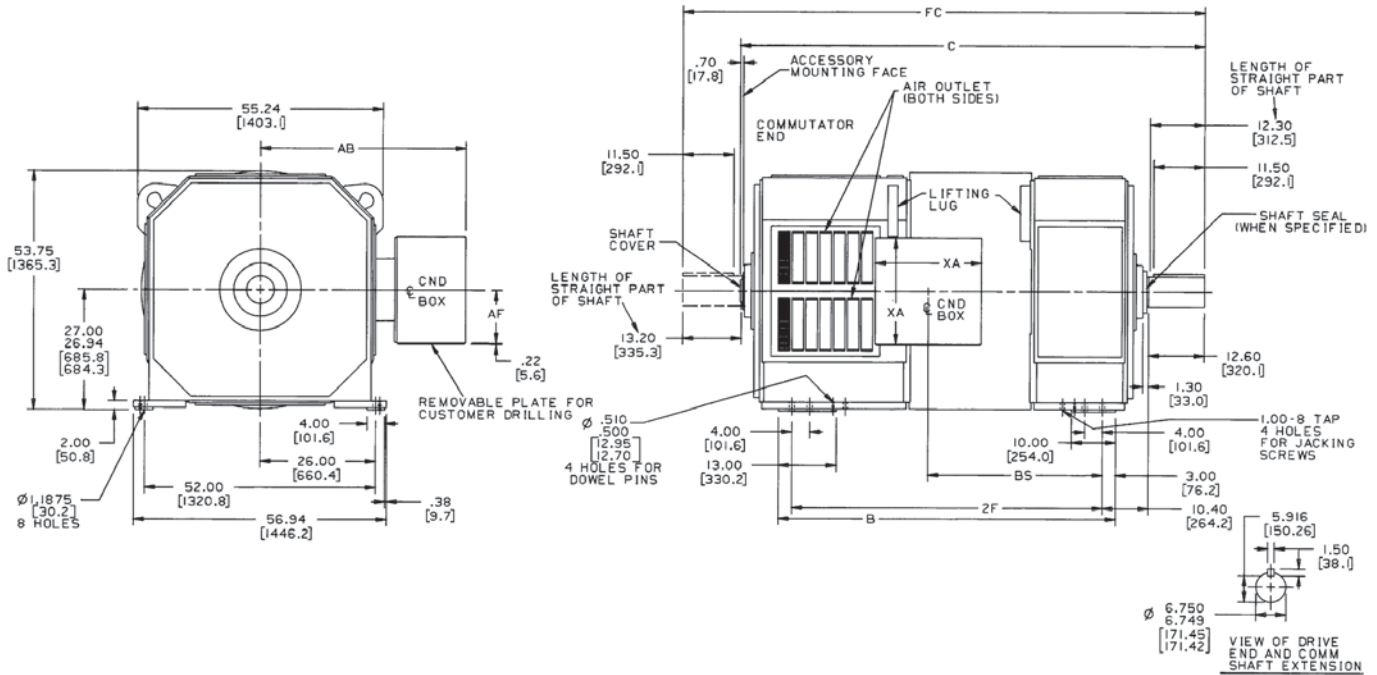

Frame	Approx. Net Wt. in Lb. ◇	Approx. Wk ² of Armature Ft. Lb.	B	2F	C	FC	BS	
							Standard Box	Oversize Box
CD6873	16000	2900	58.9	50	87.630	100.58	30.8	27.8
CD6876	17700	3230	62.9	55	91.630	104.58	34.8	31.8
CD6881	20300	4170	67.4	60	96.130	109.08	39.3	36.3
CD6882	16800	3130	67.5	60	96.230	109.18	27.8	24.8
CD6885	18500	3460	71.5	65	100.23	113.18	31.8	28.8
CD6887	23500	5480	72.9	65	101.63	114.58	44.8	41.8
CD6890	21000	4400	76.0	70	104.73	117.68	36.3	33.3
CD6896	24200	5710	81.5	75	110.23	123.18	41.8	38.8

CONDUIT BOX DIMENSIONS				
Frame	Box	AB	AF	XA
CD6873	Standard	46.75	12	24
CD6876				
CD6881	Oversize	50.75	15	30
CD6887				
CD6882	Standard	50.75	15	30
CD6885				
CD6890	Oversize	56.75	18	36
CD6896				

Accessory mounting face dimensions, see page 4.49.
 Commutator end shaft extension is furnished only when specifically ordered.
 Standard conduit box location is right hand side for motor and left hand side for generator facing commutator end. Conduit box can be assembled on the opposite side of frame, or assembled so that entrance can be made from above, from commutator end, or from drive end if so specified. Fixed termination is provided for customer connections.

Splashproof machines will have additional covers, but all dimensions will remain the same.
 Air inlet can be provided at drive end at top, bottom, or either side if so specified.
 Totally enclosed separately ventilated enclosures can be provided with both air inlet and outlet at top, bottom, or either side.
 ◇ For shipping weight, add 15% to net weight.

Outline Dimensions

DIMENSIONS - For ESTIMATING ONLY unless endorsed for construction

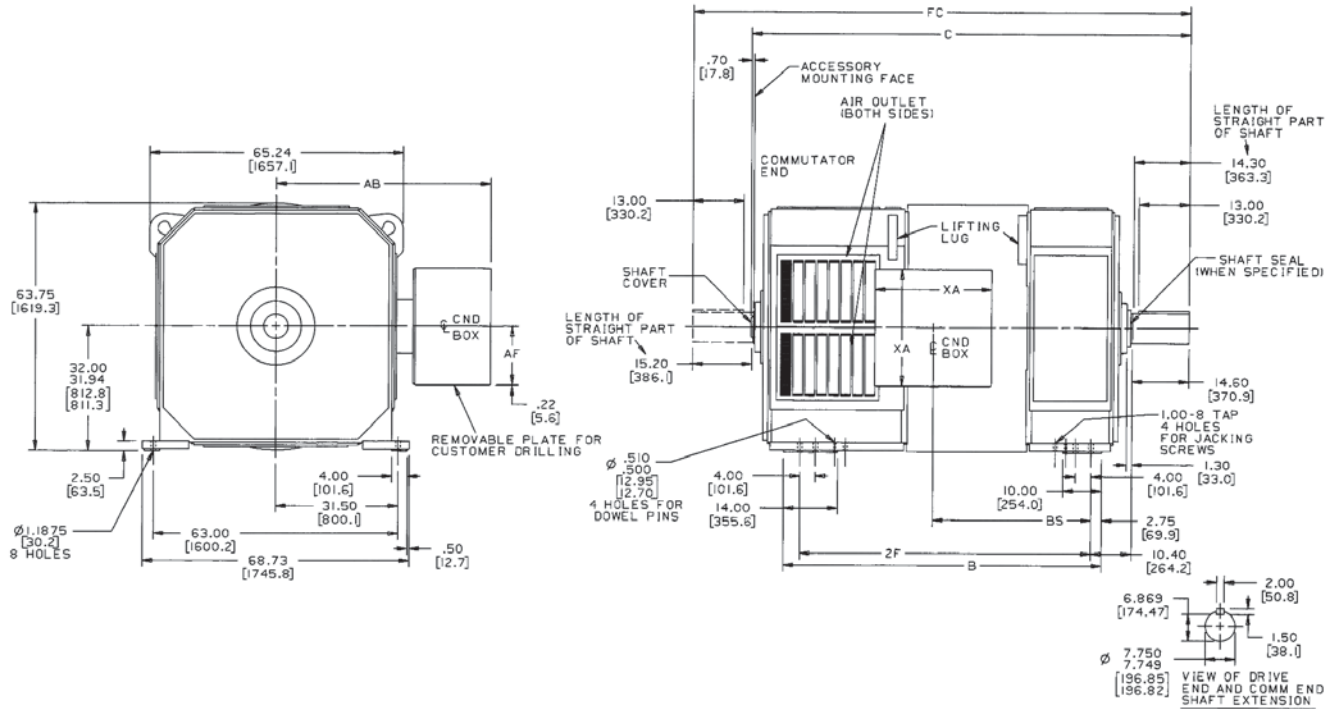

Outline Dimensions

Frame	Approx. Net Wt. in Lb. ◇	Approx. Wk ² of Armature Ft. Lb.	B	2F	C	FC	BS	
							Standard Box	Oversize Box
CD6977	23400	5100	64.4	55	95.130	110.08	34.81	31.81
CD6981	26000	6000	68.4	60	99.130	114.08	38.81	35.81
CD6985	28700	6350	73.4	65	104.13	119.08	43.81	40.81
CD6986	24300	5250	73.0	65	103.73	118.68	31.81	28.81
CD6990	26900	6200	77.0	70	107.73	122.68	35.81	32.81
CD6991	31700	8850	79.9	70	110.63	125.58	50.31	47.31
CD6996	29600	6550	82.0	75	112.73	127.68	40.81	37.81
CD6999	34400	9050	88.5	80	119.23	134.18	47.31	44.31

CONDUIT BOX DIMENSIONS				
Frame	Box	AB	AF	XA
CD6977	Standard	51.75	12	24
CD6981		51.75	12	24
CD6985	Oversize	55.75	15	30
CD6991		55.75	15	30
CD6986	Standard	55.75	15	30
CD6990		55.75	15	30
CD6996	Oversize	61.75	18	36
CD6999		61.75	18	36

Accessory mounting face dimensions, see page 4.49.
 Commutator end shaft extension is furnished only when specifically ordered.
 Standard conduit box location is right hand side for motor and left hand side for generator facing commutator end. Conduit box can be assembled on the opposite side of frame, or assembled so that entrance can be made from above, from commutator end, or from drive end if so specified. Fixed termination is provided for customer connections.

Splashproof machines will have additional covers, but all dimensions will remain the same.
 Air inlet can be provided at drive end at top, bottom, or either side if so specified.
 Totally enclosed separately ventilated enclosures can be provided with both air inlet and outlet at top, bottom, or either side.
 ◇ For shipping weight, add 15% to net weight.

Blower Unit, without Filters

Frames 6000 to 6900

Type CD

DIMENSIONS - For ESTIMATING ONLY unless endorsed for construction

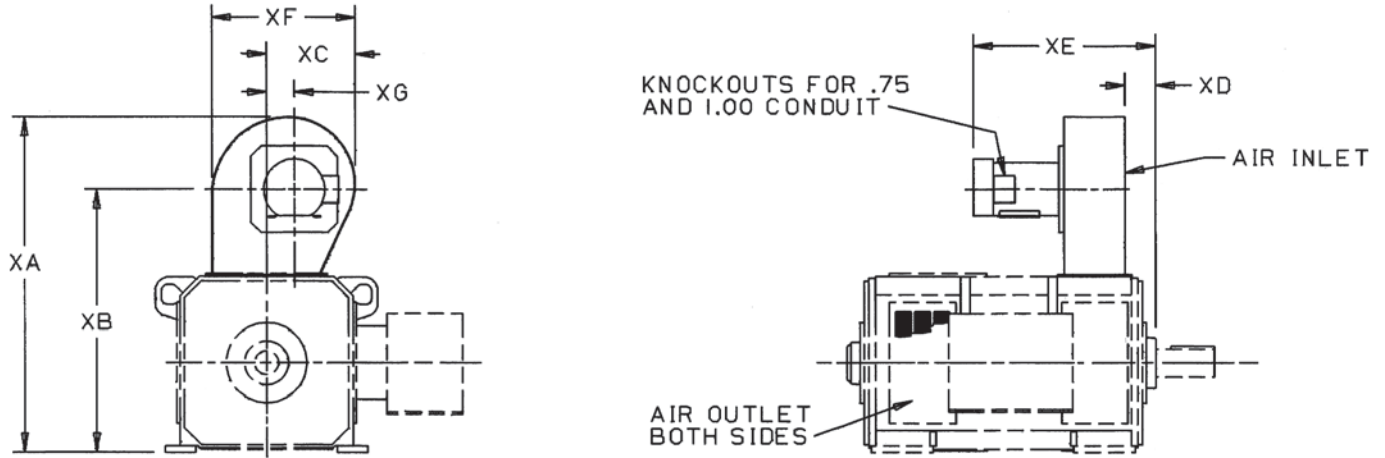

Frame	Approx. Net Wt. in Lb.	XA	XB	XC	XD	XE	XF	XG
CD6000	290	54.86	43.25	14.38	4.91	29.44	23.20	4.50
CD6100	419	62.26	48.35	17.23	4.83	35.16	27.79	5.39
CD6200	469	71.31	56.25	17.52	4.97	36.02	30.08	4.71

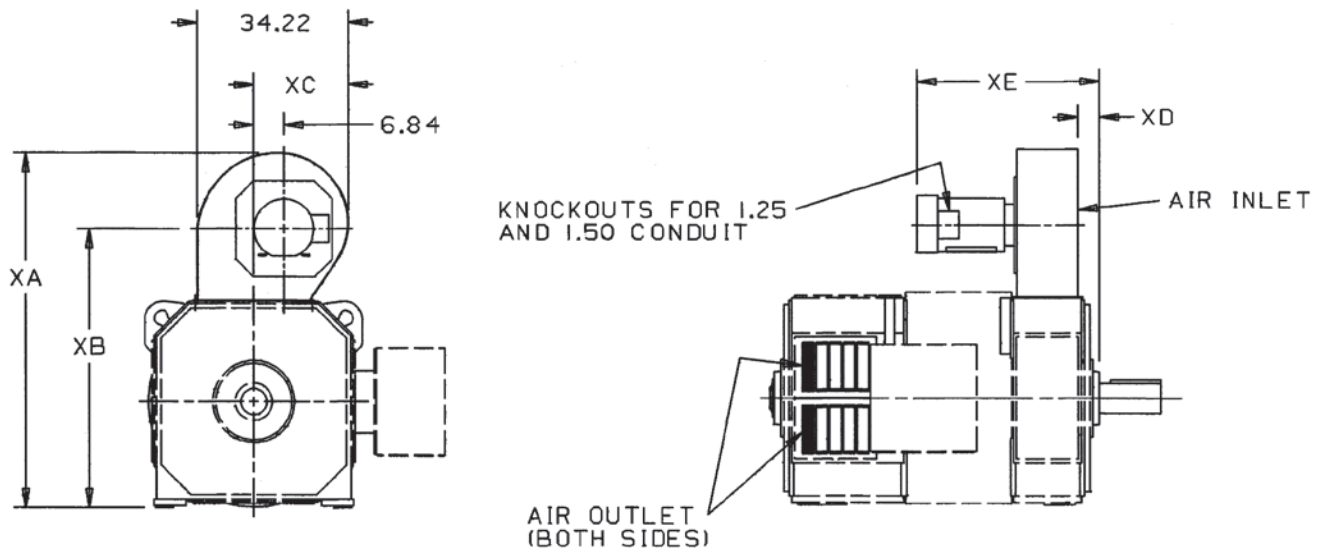

Frame	Approx. Net Wt. in Lb.	XA	XB	XC	XD	XE
CD6700	706	80.88	63.75	21.40	4.89	41.56
CD6800	732	86.88	69.75	19.92	7.14	44.31
CD6900	770	96.88	79.75	16.90	7.39	44.56

Outline Dimensions

From 36B476120AA, 36B476120AB

Blower Unit, with Filters

Frames 6000 to 6900

Type CD

DIMENSIONS - For ESTIMATING ONLY unless endorsed for construction

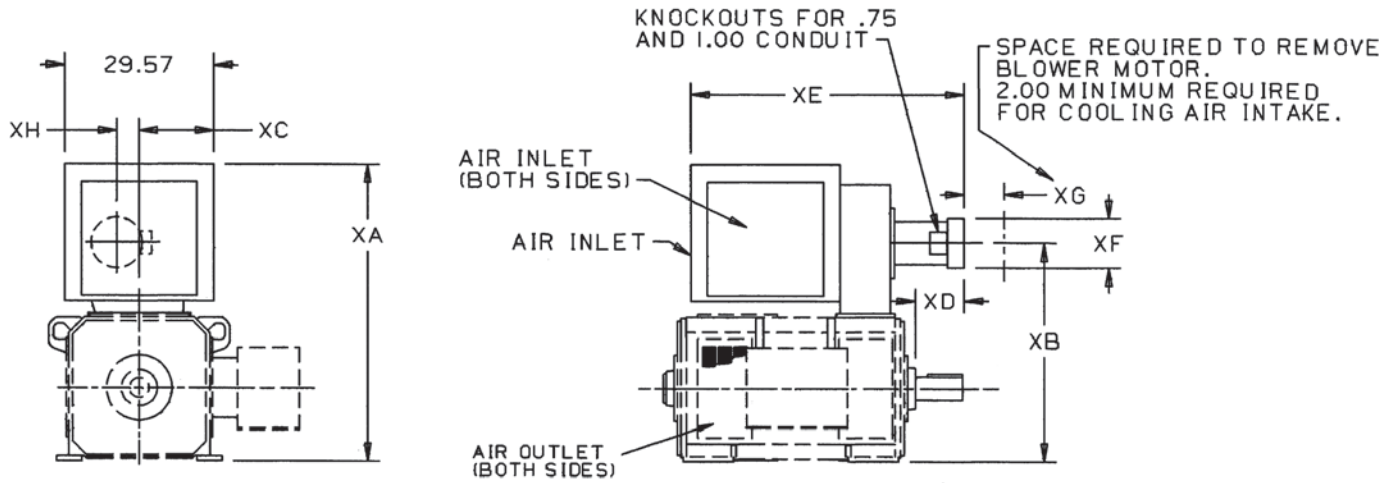

Frame	Approx. Net Wt. in Lb.	XA	XB	XC	XD	XE	XF	XG	XH
CD6000	398	58.88	43.25	14.79	9.760	54.23	10.16	8.060	4.50
CD6100	525	63.98	48.35	12.79	13.48	60.03	11.70	9.900	5.39
CD6200	573	71.88	56.25	12.79	13.34	60.75	11.70	10.49	4.71

Outline Dimensions

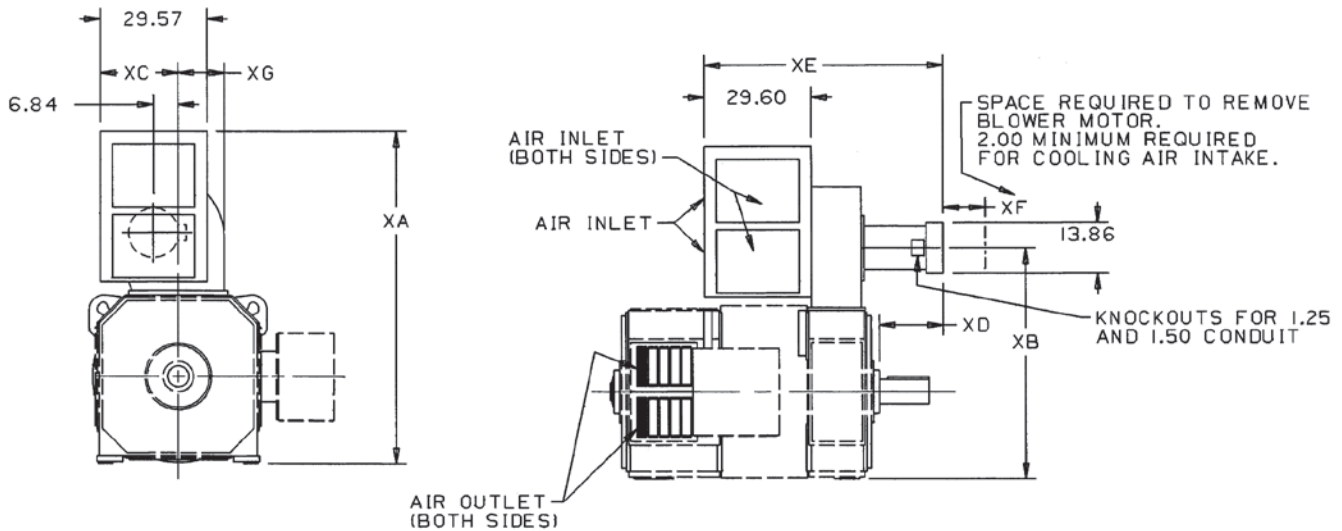

Frame	Approx. Net Wt. in Lb.	XA	XB	XC	XD	XE	XF	XG
CD6700	848	91.82	63.75	21.63	17.98	66.36	11.55	12.81
CD6800	874	97.82	69.75	20.14	15.73	66.86	11.80	14.30
CD6900	912	107.82	79.75	17.13	15.48	66.86	11.80	17.30

From 36B476120BA, 36B476120BB

Blower Unit, with Filters

Frames 6000 to 6900

Splashproof Fully Guarded

Type CD

DIMENSIONS - For ESTIMATING ONLY unless endorsed for construction

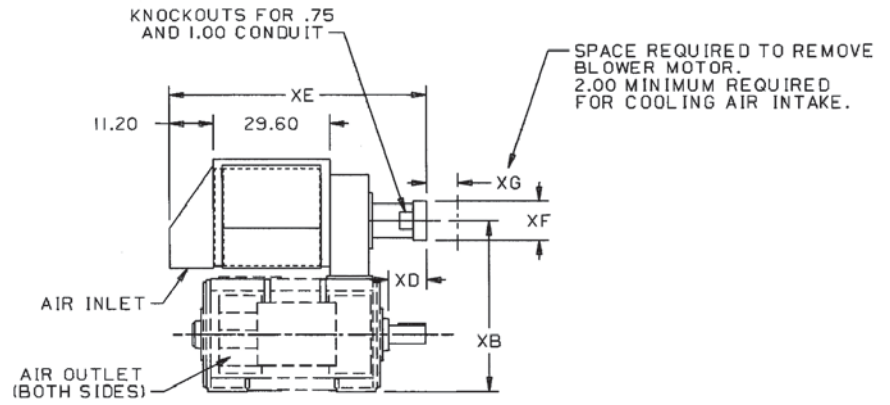
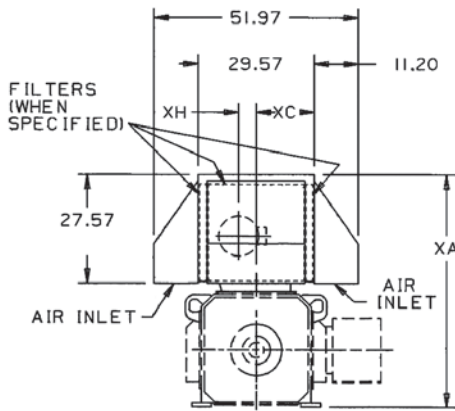

Frame	Approx. Net Wt. in Lb.	XA	XB	XC	XD	XE	XF	XG	XH
CD6000	443	55.88	43.25	14.79	9.760	65.43	10.16	8.06	4.50
CD6100	570	63.98	48.35	12.79	13.48	71.23	11.70	9.90	5.39
CD6200	618	71.88	56.25	12.79	13.34	71.95	11.70	10.49	4.71

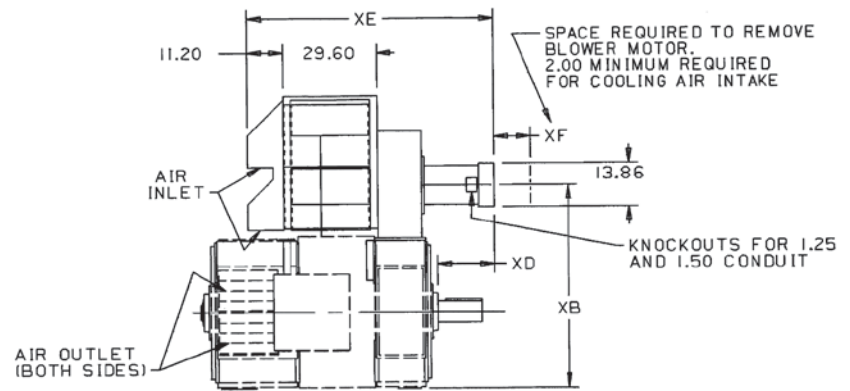
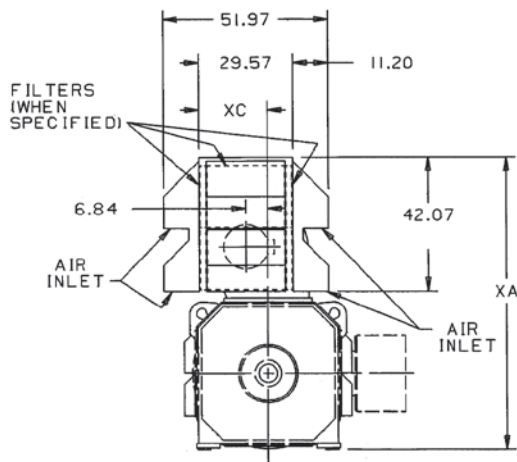

Frame	Approx. Net Wt. in Lb.	XA	XB	XC	XD	XE	XF
CD6700	938	91.820	63.75	21.63	17.98	77.56	11.55
CD6800	964	97.820	69.75	20.14	15.73	78.06	11.80
CD6900	1002	107.82	79.75	17.13	15.48	78.06	11.80

Outline Dimensions

From 36B476120CA, 36B476120CB

DIMENSIONS - For ESTIMATING ONLY unless endorsed for construction

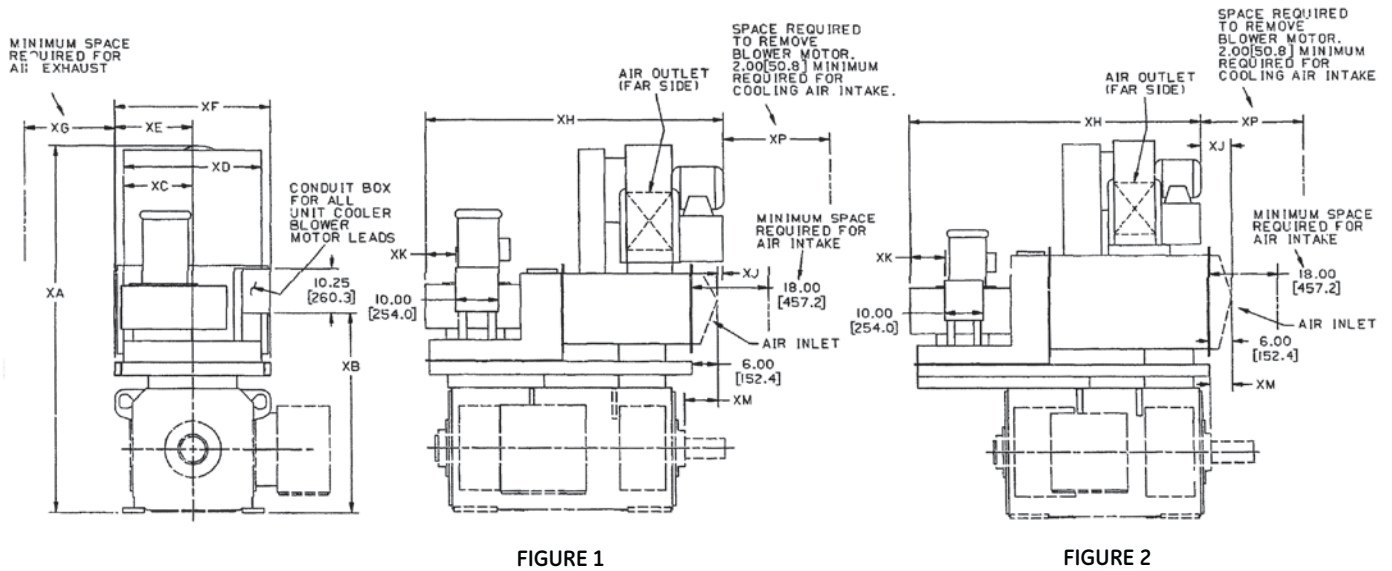

Frame	Fig.	Approx. Net Wt. in Lb.	XA	XB	XC	XD	XE	XF	XG	XH	XJ	XK	XM	XP
CD6000	1	1300	84.50	46.0	16	32	18	36	20.56	70.34	2.16	6.500	7.84	25
CD6100	2	1700	97.60	51.1	18	36	20	40	18.56	77.22	5.91	8.120	5.84	27
CD6200	2	2100	105.5	59.0	18	36	20	40	18.56	81.97	3.90	10.56	5.84	29

Outline Dimensions

DIMENSIONS - For ESTIMATING ONLY unless endorsed for construction

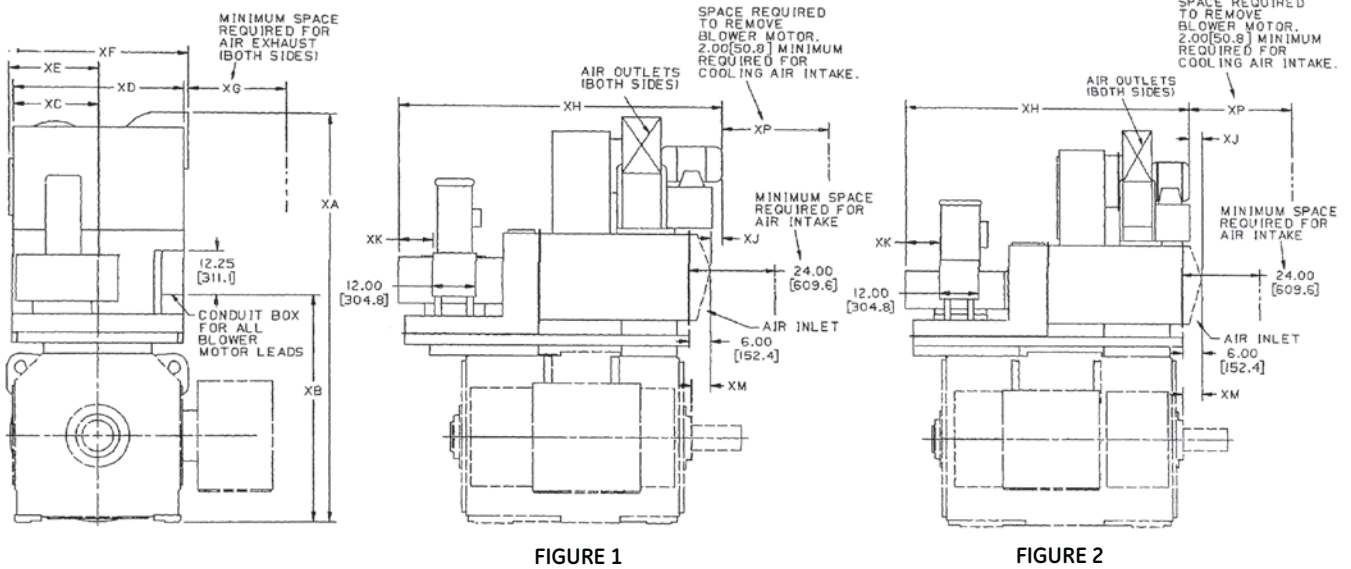

Frame	Fig.	Approx. Net Wt. in Lb.	XA	XB	XC	XD	XE	XF	XG	XH	XJ	XK	XM	XP
CD6700	1	2400	114.0	63	23.25	46.5	24.44	48.88	27	89.940	3.06	9.440	5.39	30
CD6800	2	2900	122.5	70	25.50	51.0	26.88	53.75	30	90.030	1.84	11.12	6.03	32
CD6900	2	3900	140.5	80	25.50	51.0	26.88	53.75	30	101.15	1.84	11.12	5.77	32

Outline Dimensions

DIMENSIONS - For ESTIMATING ONLY unless endorsed for construction

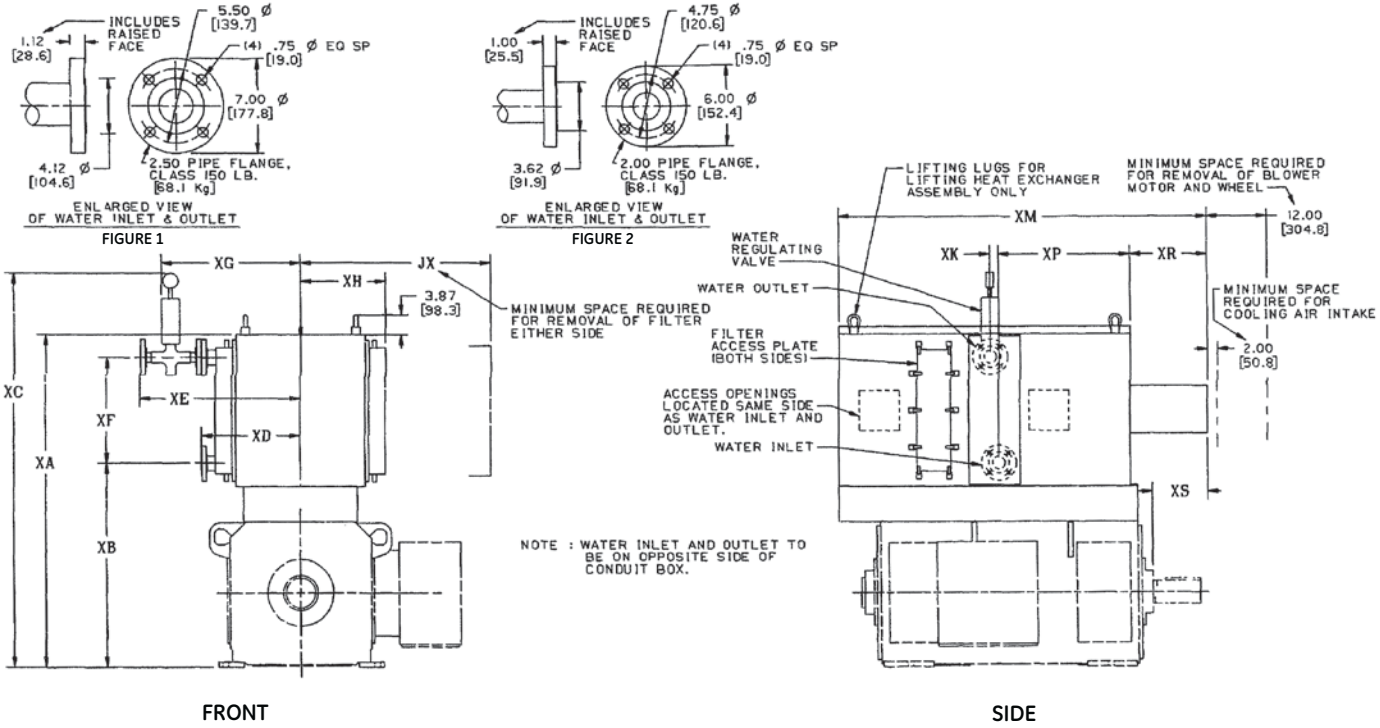

Outline Dimensions

Frame	Approx. Net Wt. in Lb.	XA	XB	XC	XD	XE	XF	XG	XH	XJ	XK	XM	XP	XR	XS
CD6000	1500	65.63	40.13	77.73	19.5	31.63	21.00	27.44	16.75	37.75	1.75	73.70	26.25	15.5	11.1
CD6100	1500	74.98	45.23	87.08	22.5	34.63	25.25	30.44	19.75	29.75	1.75	89.98	27.13	20.9	16.5
CD6200	1800	78.63	53.13	91.24	27.0	39.13	21.50	34.94	24.25	36.25	2.25	92.28	26.88	20.9	16.5

DIMENSIONS - For ESTIMATING ONLY unless endorsed for construction

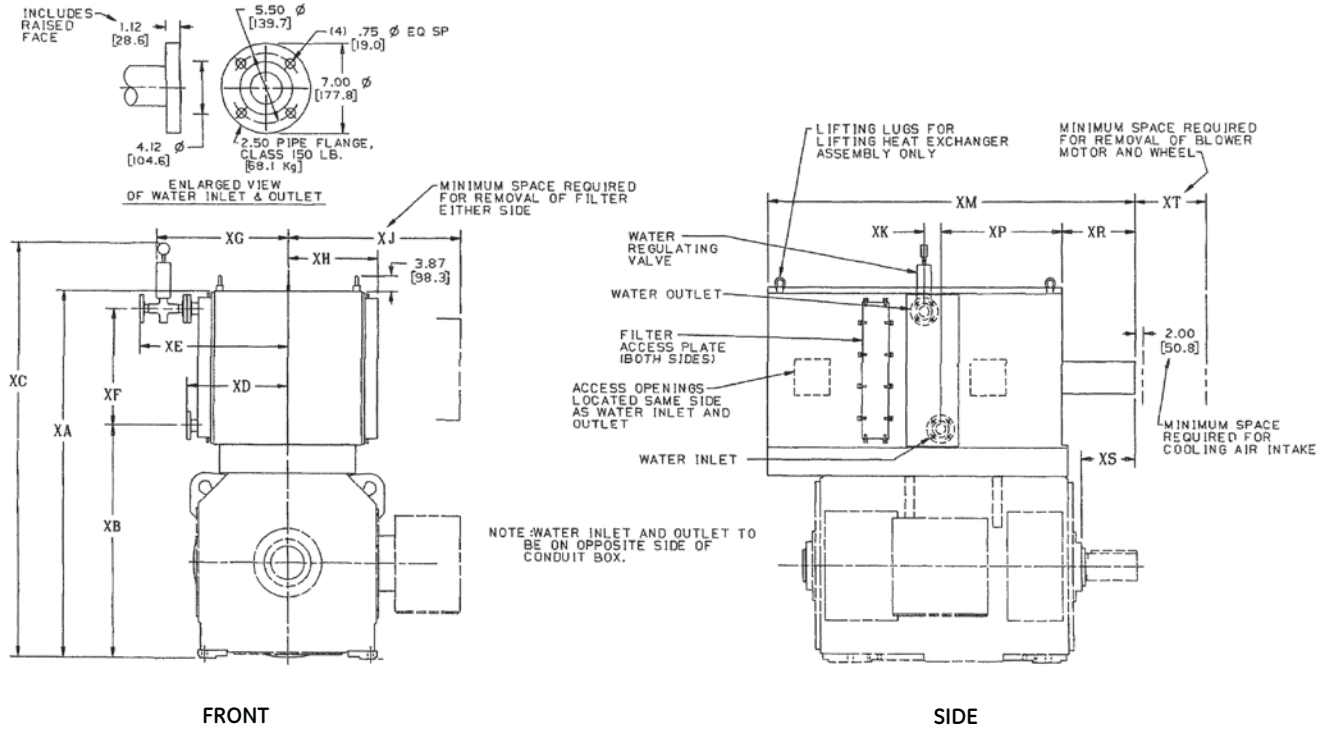

Frame	Approx. Net Wt. in Lb.	XA	XB	XC	XD	XE	XF	XG	XH	XJ	XK	XM	XP	XR	XS	XT
CD6700	2200	92.070	58.13	104.16	25.50	37.63	29.43	33.44	22.75	43.75	4.25	93.05	30.63	18.50	13.56	18.0
CD6800	2800	116.13	64.13	128.23	27.00	39.13	47.50	34.84	24.25	45.25	4.25	115.0	36.33	28.00	23.06	18.0
CD6900	3000	116.25	73.75	127.70	31.57	43.57	38.37	39.38	28.75	53.75	6.75	117.8	42.75	23.81	18.86	22.5

Outline Dimensions

Dimensions, Air Openings

Frames 6050 to 6066

Type CD

DIMENSIONS - For ESTIMATING ONLY unless endorsed for construction

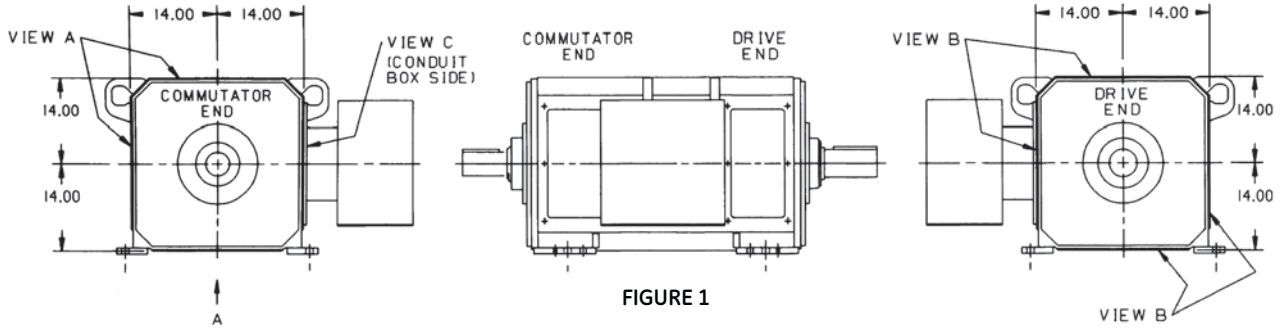

FIGURE 1

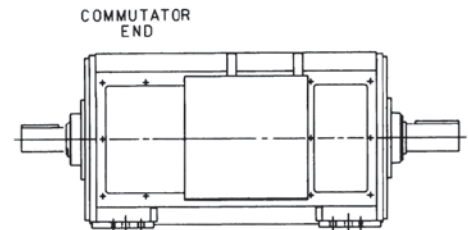
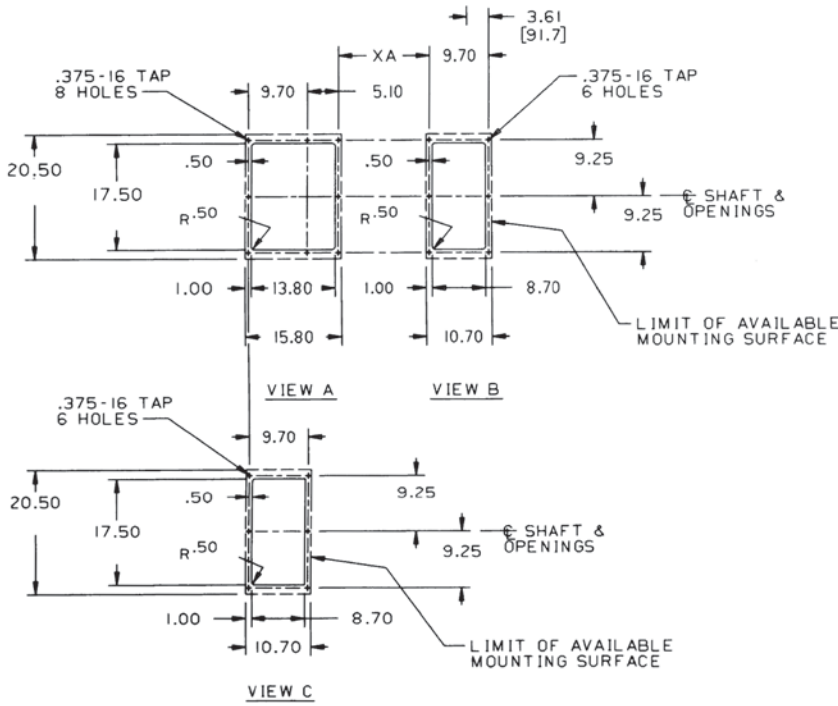
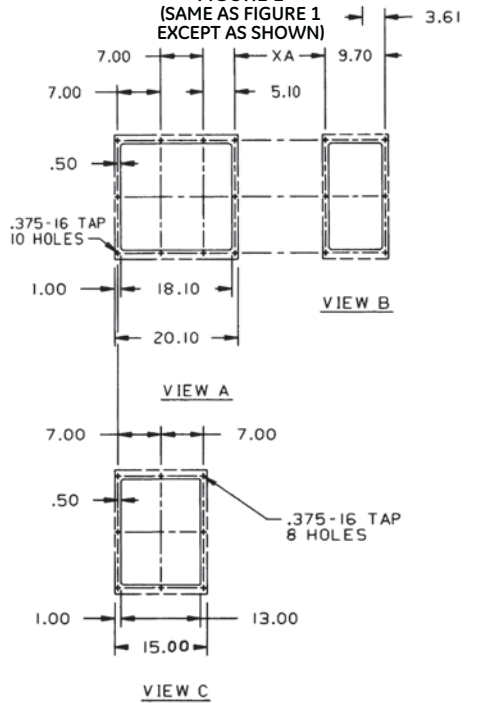

FIGURE 2
(SAME AS FIGURE 1
EXCEPT AS SHOWN)



Outline Dimensions

Frame	Figure	XA
CD6050	1	14.8
CD6054	2	16.9
CD6052	1	19.5
CD6057	2	22.7
CD6055	1	26.7
CD6059	2	
CD6058	1	
CD6063	2	
CD6062	1	
CD6066	2	

From 36C706070BA

Dimensions, Air Openings

Frames 6154 to 6177

Type CD

DIMENSIONS - For ESTIMATING ONLY unless endorsed for construction

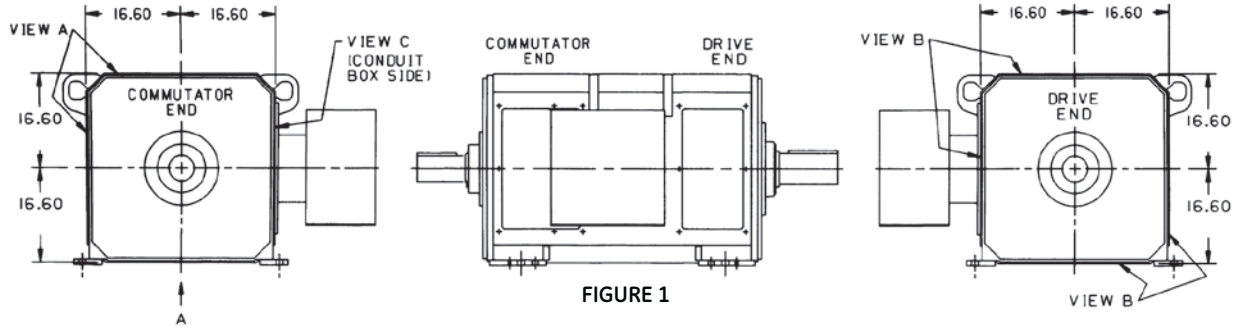

FIGURE 1

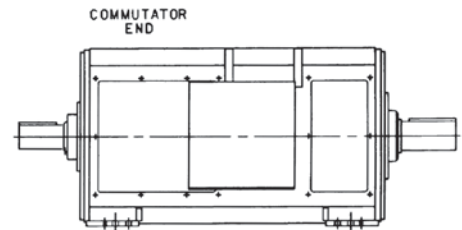
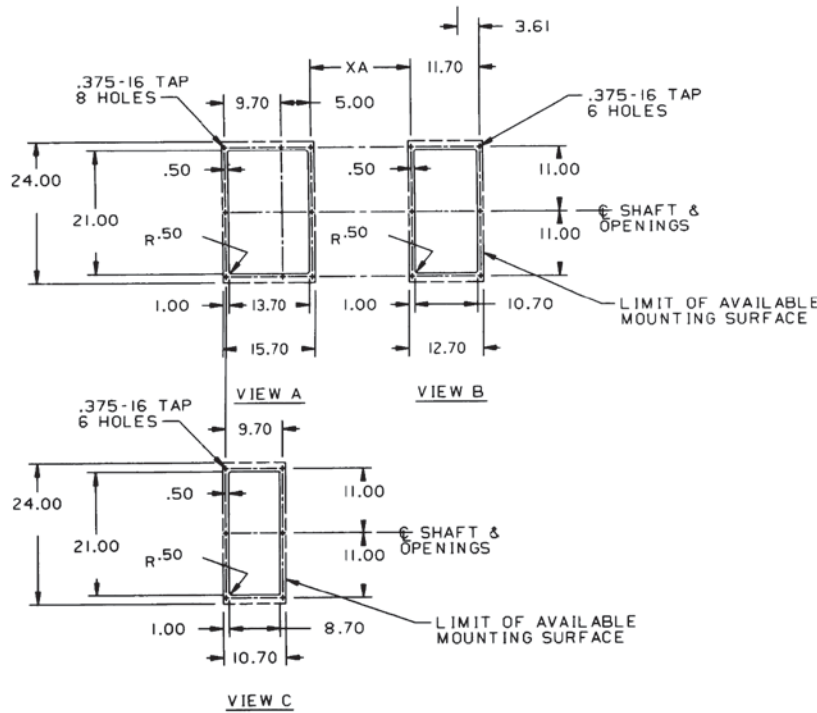
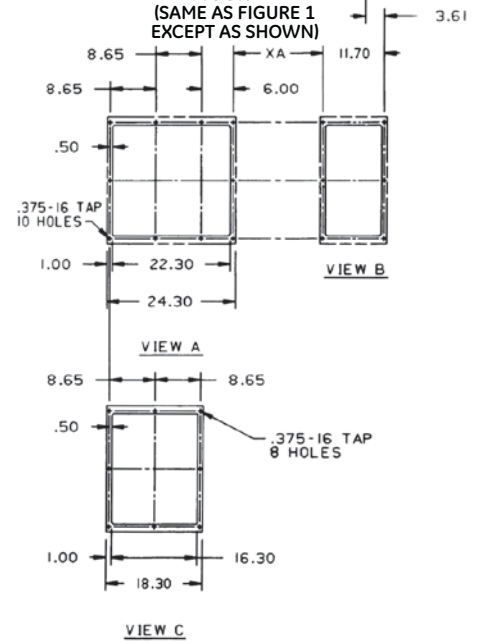

FIGURE 2
(SAME AS FIGURE 1
EXCEPT AS SHOWN)



Frame	Figure	XA
CD6154	1	17.0
CD6163	2	19.6
CD6157	1	22.8
CD6165	2	26.8
CD6160	1	31.4
CD6168	2	
CD6164	1	
CD6173	2	
CD6169	1	
CD6177	2	

Outline Dimensions

From 36C706070BB

Dimensions, Air Openings

Frames 6259 to 6280

Type CD

DIMENSIONS - For ESTIMATING ONLY unless endorsed for construction

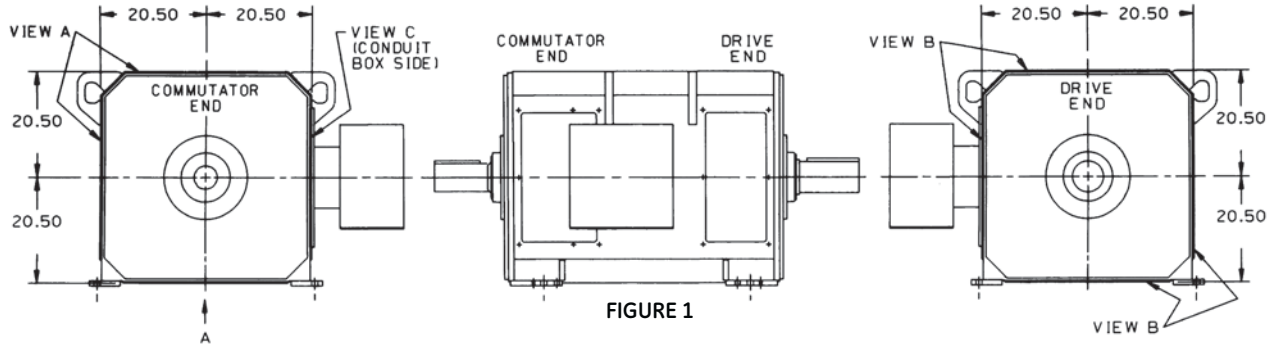

FIGURE 1

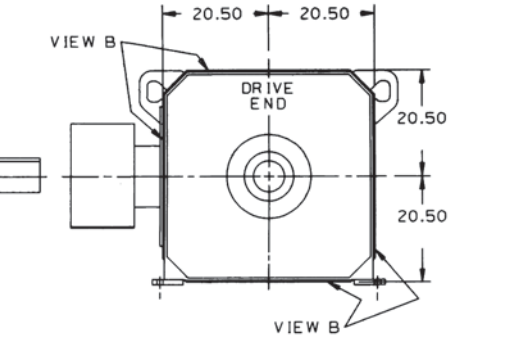
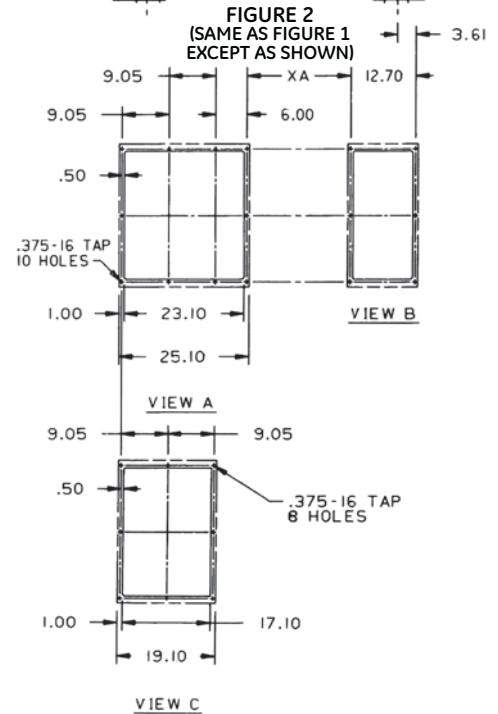
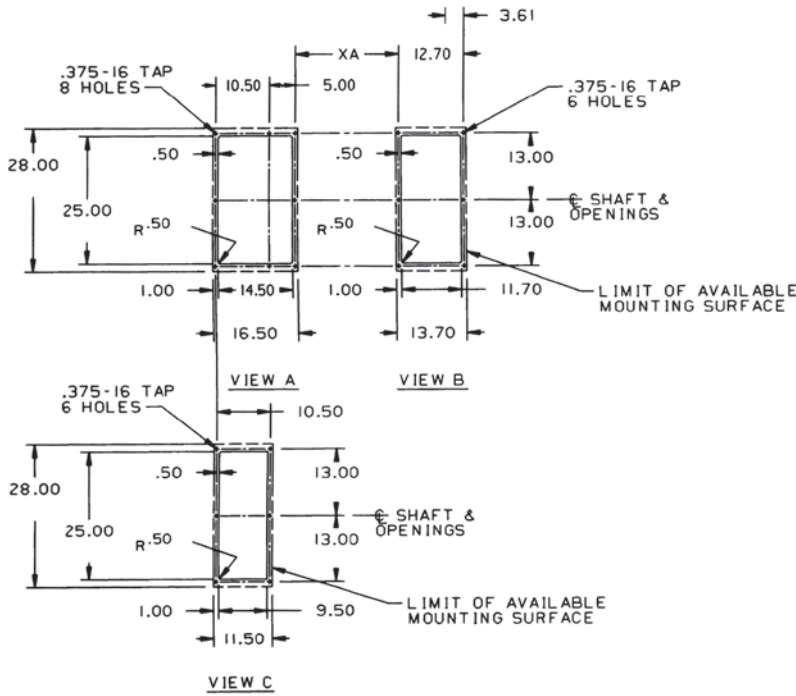

FIGURE 2
(SAME AS FIGURE 1
EXCEPT AS SHOWN)



Outline Dimensions

Frame	Figure	XA
CD6259	1	20.1
CD6268	2	20.1
CD6262	1	23.3
CD6270	2	23.3
CD6266	1	27.3
CD6275	2	27.3
CD6271	1	31.9
CD6280	2	31.9

From 36C706070BC

Dimensions, Air Openings

Frames 6766 to 6785

Type CD

DIMENSIONS - For ESTIMATING ONLY unless endorsed for construction

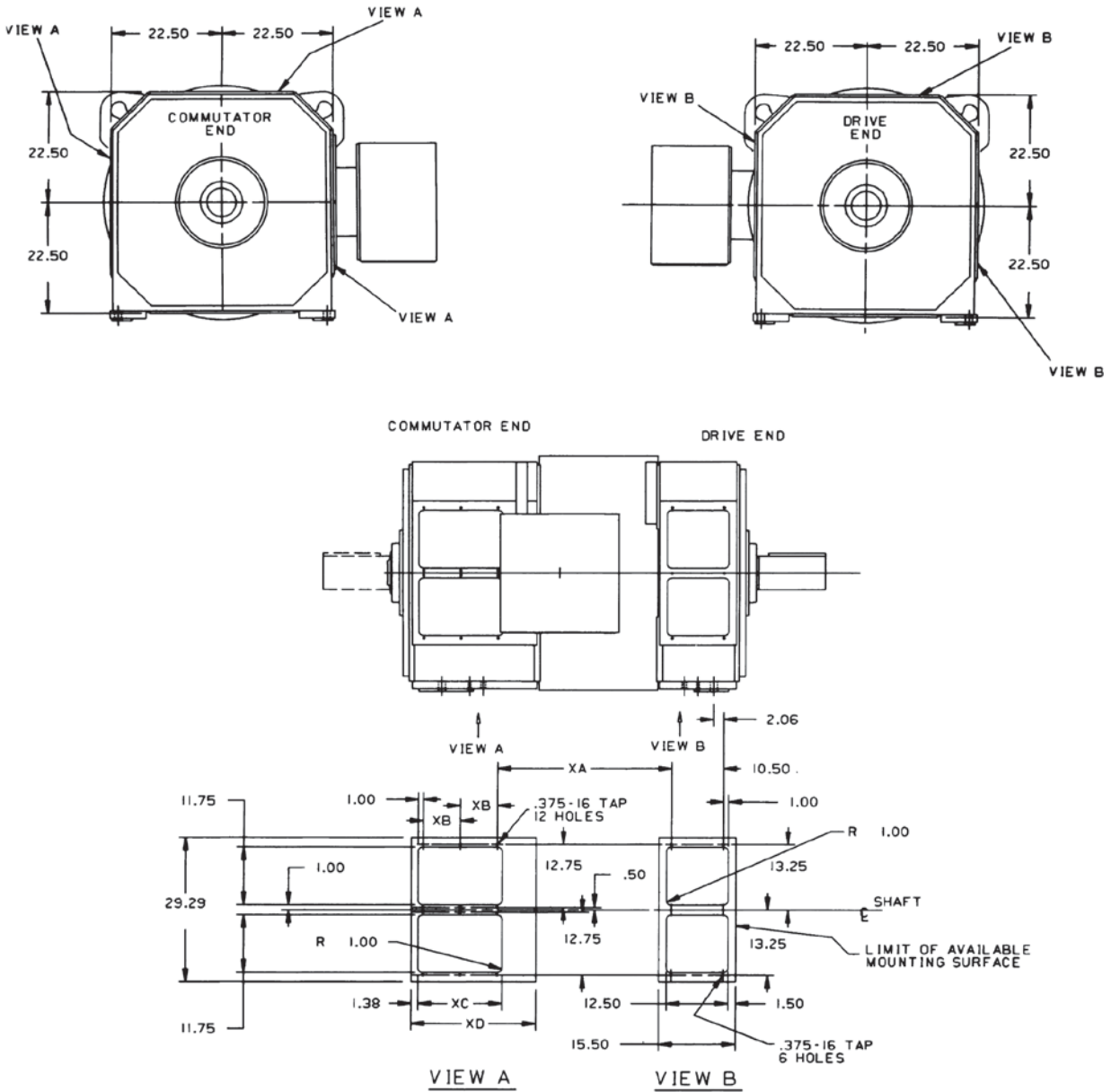

Outline Dimensions

Frame	XA	XB	XC	XD
CD6766	27.67	7.50	17.0	25.25
CD6770	31.17			
CD6774	35.17			
CD6779	40.17			
CD6771	27.67	9.65	21.3	29.55
CD6776	31.17			
CD6778	35.17			
CD6785	40.17			

From 36C706070AA

Dimensions, Air Openings

Frames 6873 to 6896

Type CD

DIMENSIONS - For ESTIMATING ONLY unless endorsed for construction

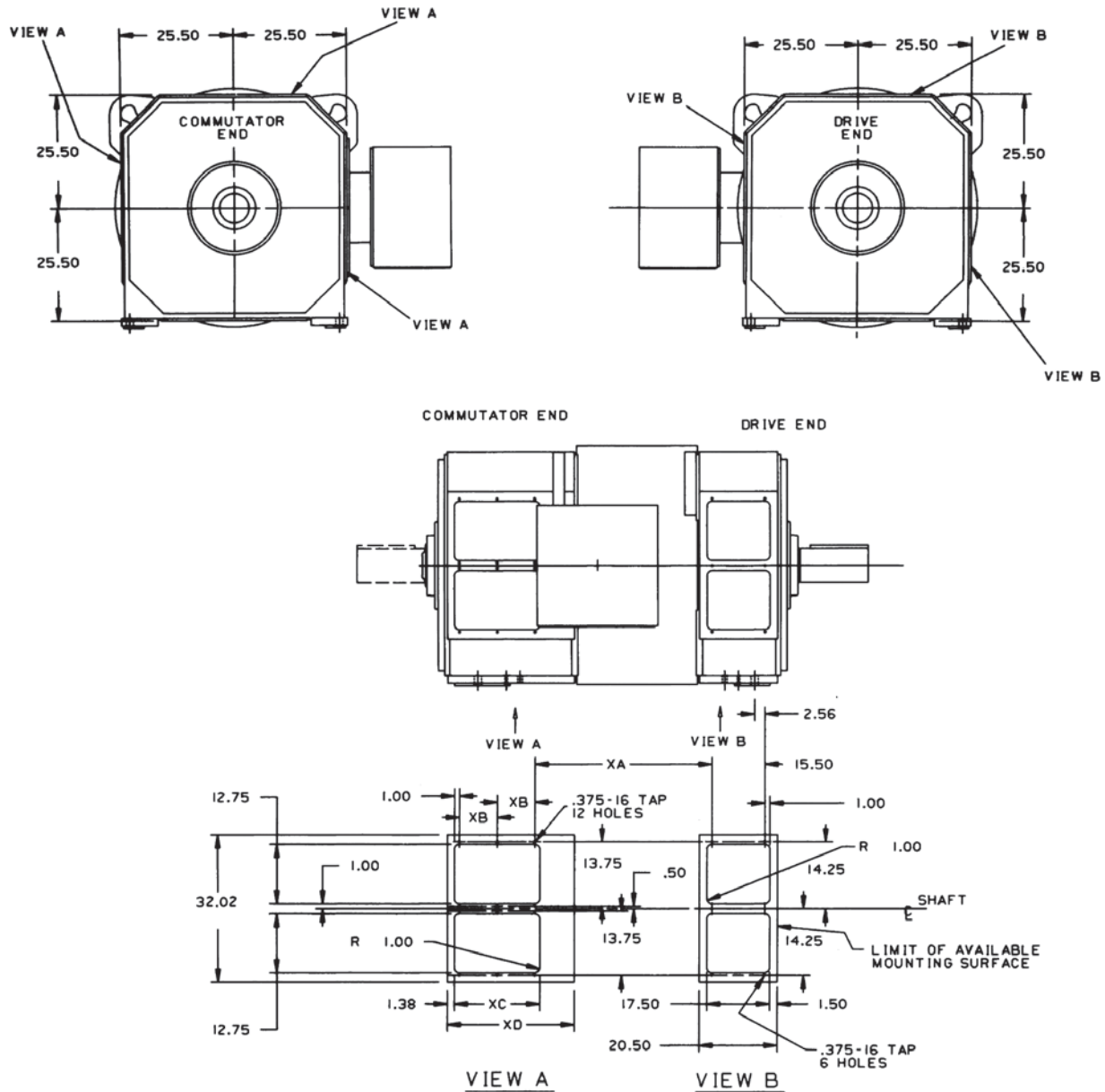

Outline Dimensions

Frame	XA	XB	XC	XD
CD6873	30.55	6.20	14.4	18.0
CD6876	34.55			
CD6881	39.05			
CD6887	44.55			
CD6882	30.55	10.5	23.0	26.6
CD6885	34.55			
CD6890	39.05			
CD6896	44.55			

From 36C706070AB

Dimensions, Air Openings

Frames 6977 to 6999

Type CD

DIMENSIONS - For ESTIMATING ONLY unless endorsed for construction

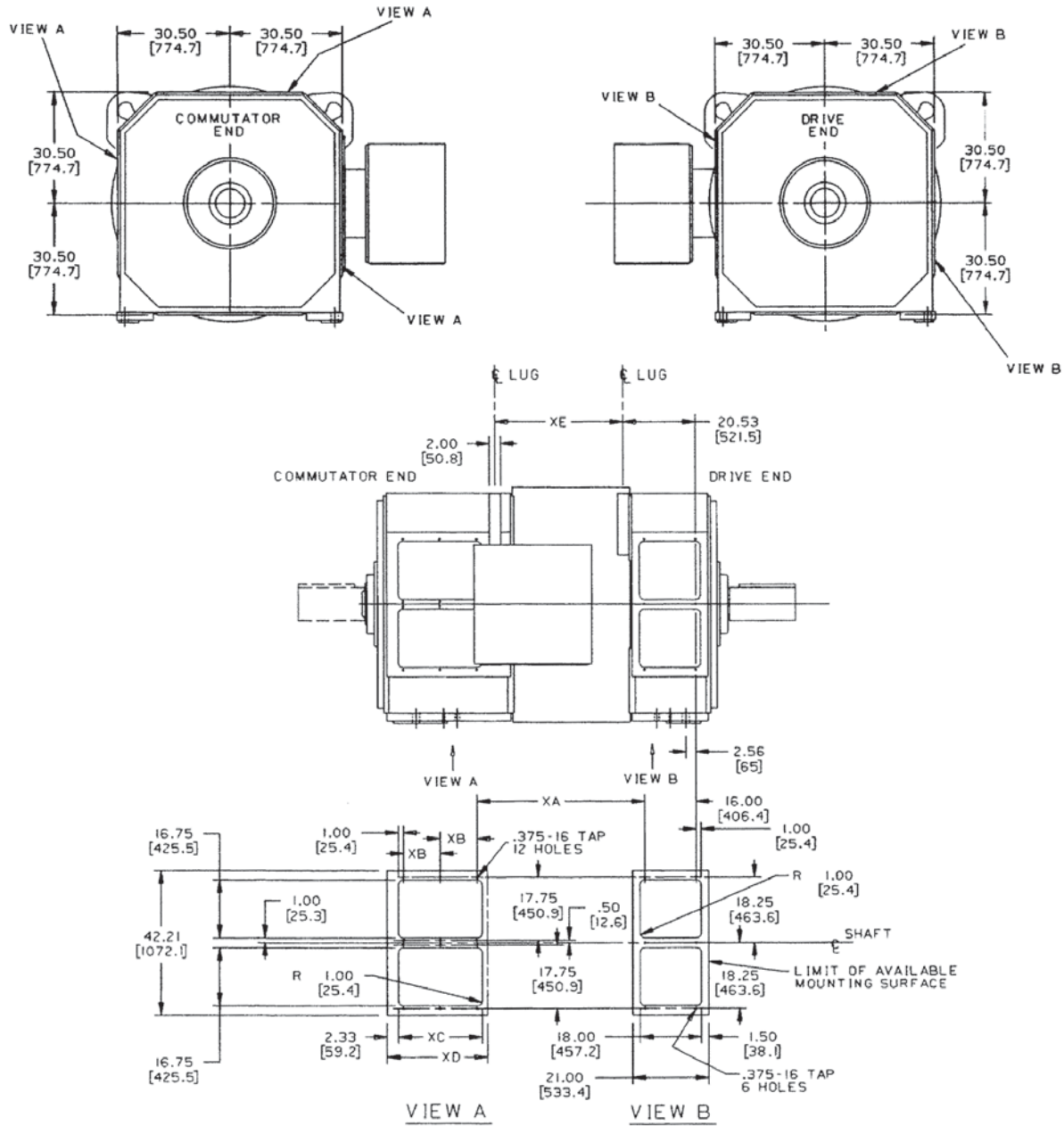

Frame	XA	XB	XC	XD
CD6977	33.97	7.20	16.4	19.8
CD6981	37.97			
CD6985	42.97			
CD6991	49.47			
CD6986	33.97	11.5	25.0	28.4
CD6990	37.97			
CD6996	42.97			
CD6999	49.47			

From 36C706070AC

Accessory Mountings

Frames 180AT to 5010AY

For All Motors Except Those
with TEFC Enclosure

Type CD

DIMENSIONS - For ESTIMATING ONLY unless endorsed for construction

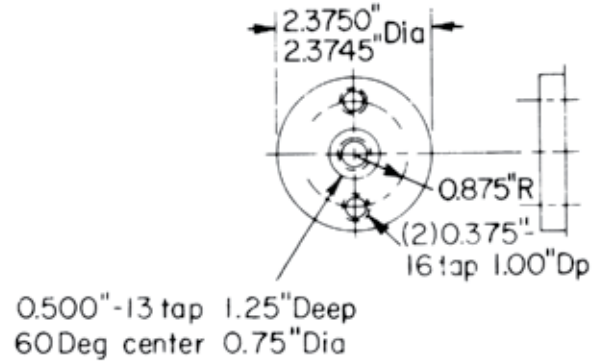
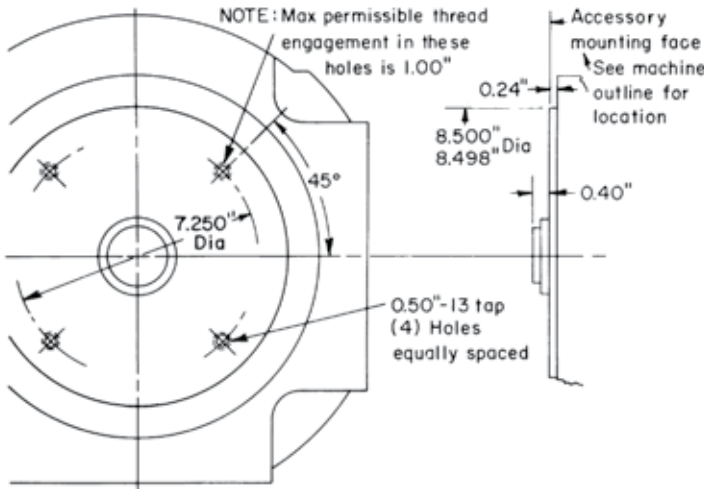

CD400AT

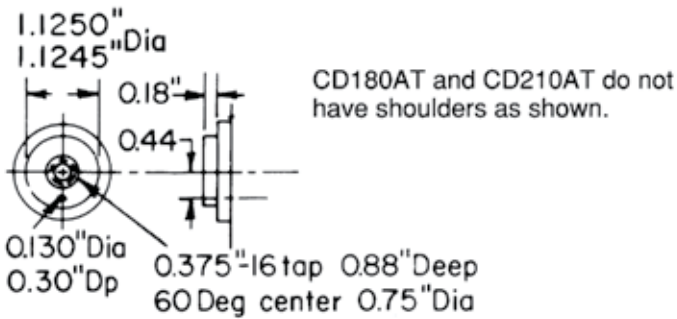

CD180AT-320AT

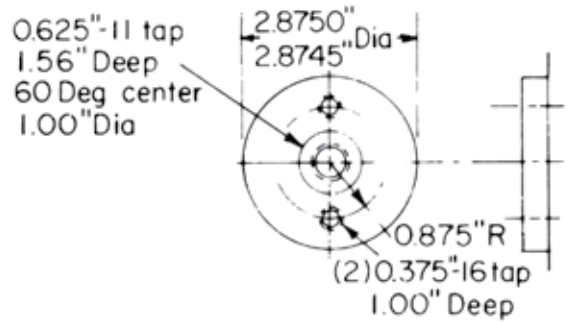

CD500AT-
CD5010AY

NOTES:

Accessories shaft as shown furnished on all machines not having commutator end shaft extensions.

Accessories shaft is suitable for driving tachometer and speed limit switch.

Tapped hole is not concentric with shaft diameters.

For brake application a keyed commutator end shaft extension is required.

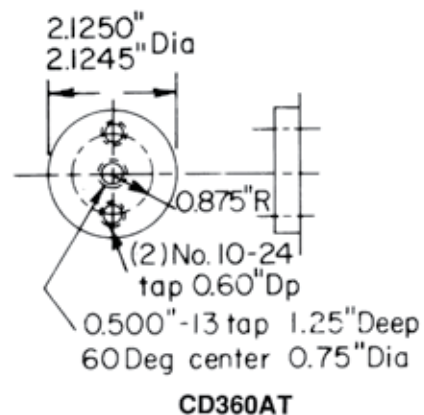

CD360AT

Standard Commutator End Bracket and Accessory Shaft Extension on CD180AT-CD500AT Machines
(Dimensions do not apply to TEFC machines.)

From 36C697103AA

Accessory Mountings

Frames 6000 to 6900

Type CD

DIMENSIONS - For ESTIMATING ONLY unless endorsed for construction

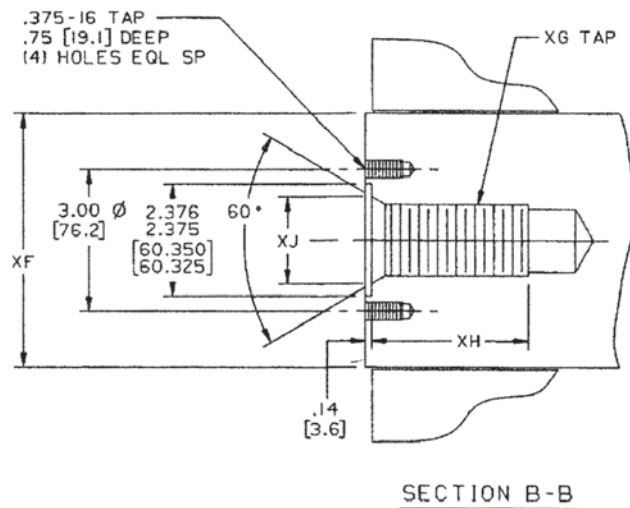
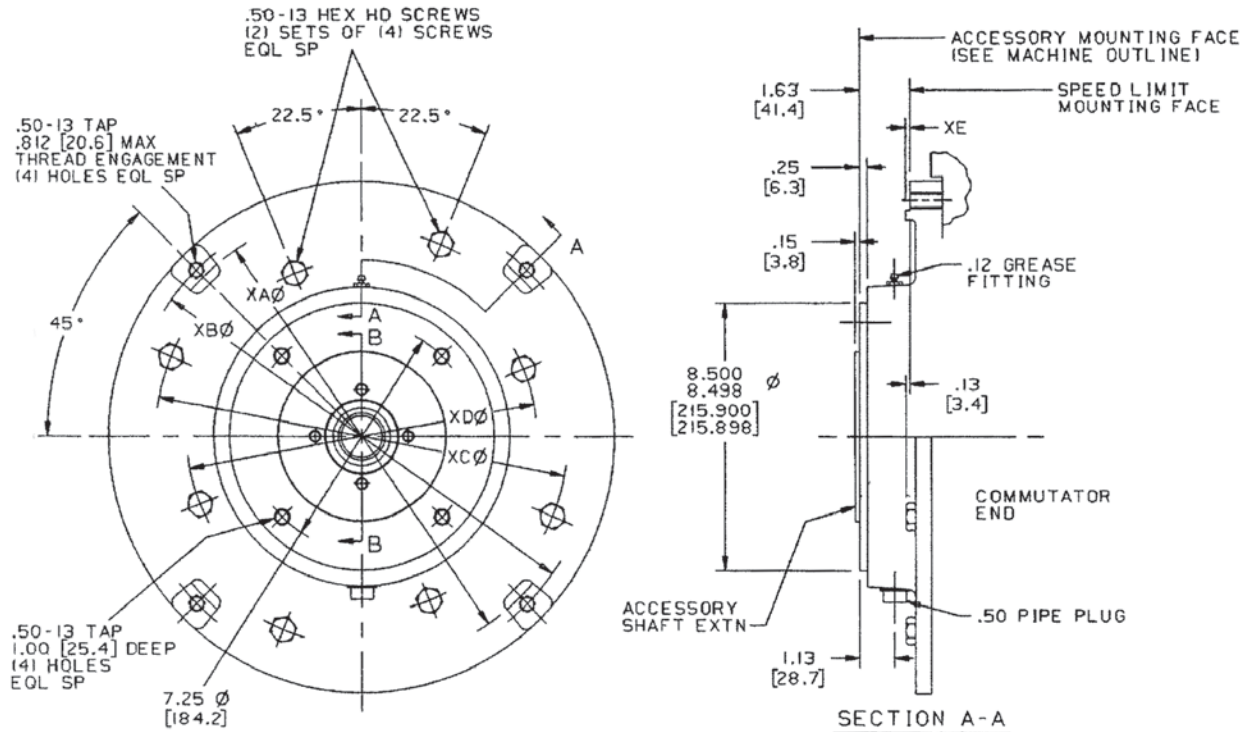

Frame	XAO	XBO	XCO	XDO	XE	XFO	XG	XH	XJO
CD6000	11.125	11.75	11.75	9.875	0.12	3.875	1.00-8	2.38	1.5
	11.123								
CD6100	11.125	11.75	11.75	9.750	0.12	4.500	1.00-8	2.38	1.5
	11.123								
CD6200	14.375	15.00	13.25	11.25	0.12	5.375	1.50-6	3.50	2.0
	14.372								
CD6700	14.375	15.00	16.00	14.00	0.12	6.215	1.50-6	3.50	2.0
CD6800	14.372								
CD6900	14.375	15.00	17.50	15.50	0.14	6.215	1.50-6	3.50	2.0
	14.372								

From 36C706009AA

Accessory Couplings

Frames 180AT to 500AT and 6000 to 6900

Type CD

DIMENSIONS - For ESTIMATING ONLY unless endorsed for construction

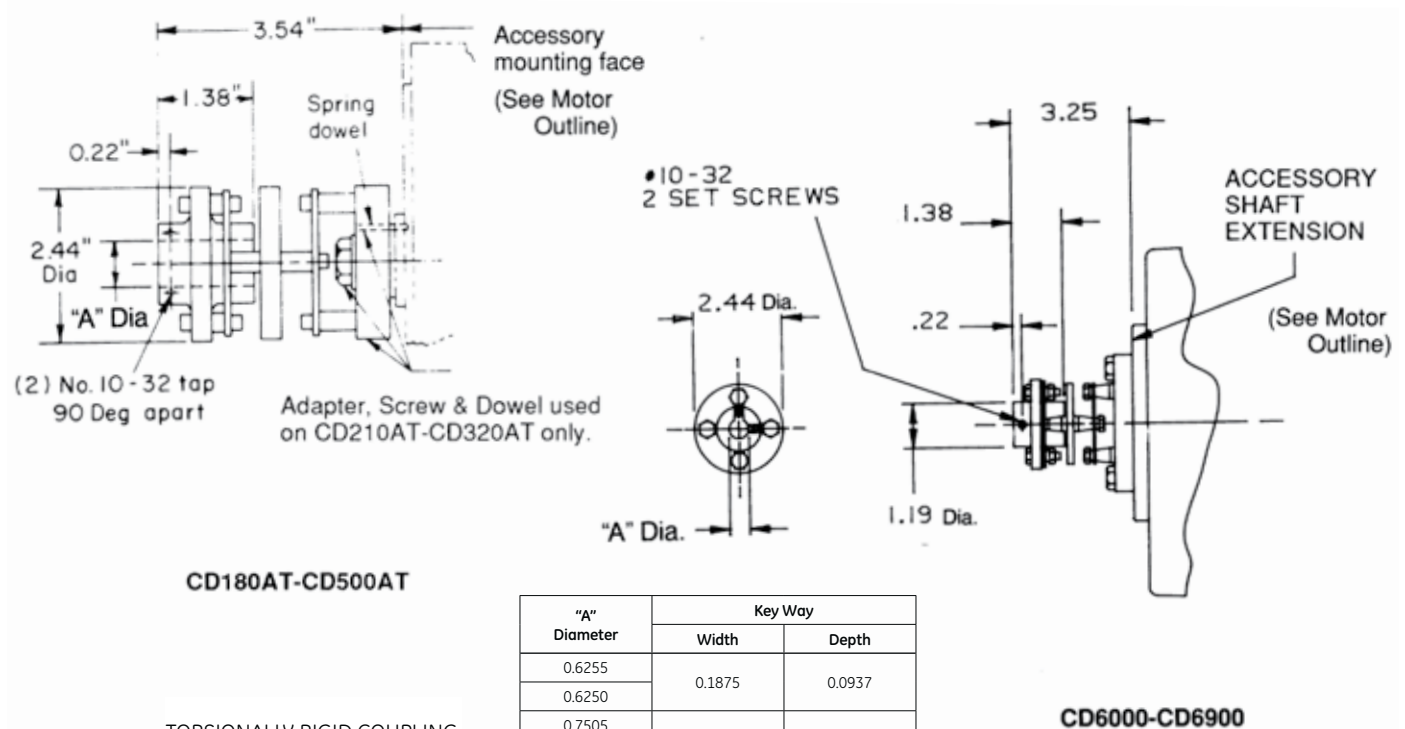

CD180AT-CD500AT

CD6000-CD6900

TORSIONALLY RIGID COUPLING
RATED AT .17 HP
PER 100 RPM

"A" Diameter	Key Way	
	Width	Depth
0.6255	0.1875	0.0937
0.6250		
0.7505		
0.7500		
0.5005	OMIT	
0.5000	OMIT	
0.3130	OMIT	
0.3123	OMIT	

Outline Dimensions

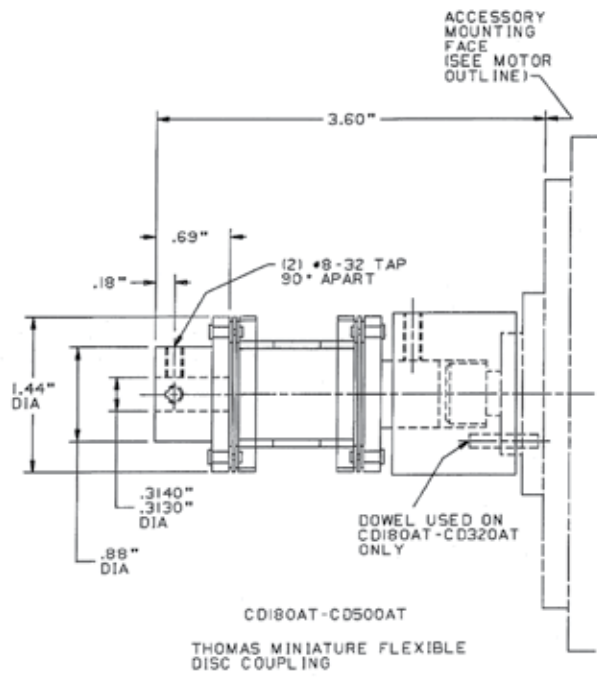

CD180AT-CD500AT
THOMAS MINIATURE FLEXIBLE DISC COUPLING

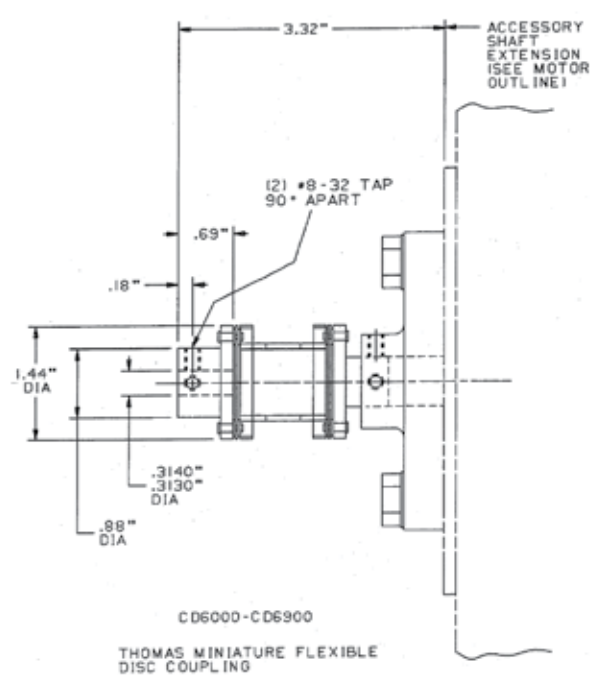

CD6000-CD6900
THOMAS MINIATURE FLEXIBLE DISC COUPLING

Accessory Adapters

Frames 180AT to 500AT and 6000 to 6900

Type CD

DIMENSIONS - For ESTIMATING ONLY unless endorsed for construction

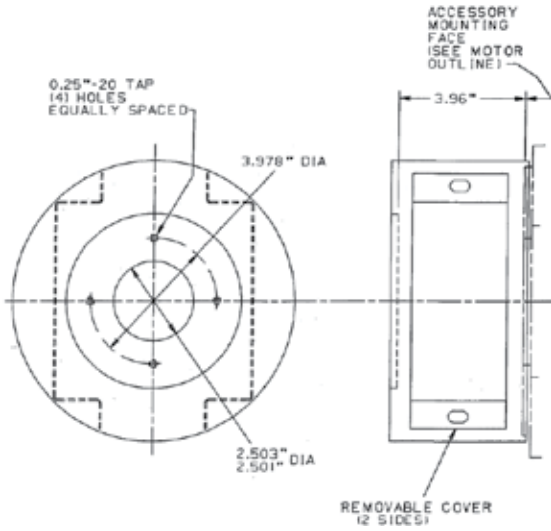

Form "Y" tachometer adapter mounts on bracket (See motor outline.)

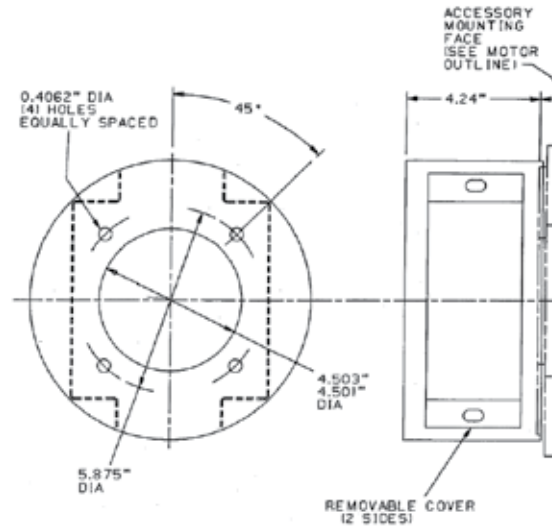

BC42/BC46 tachometer adapter mounts on bracket (See motor outline.)

Outline Dimensions

Speed Limit Device

Frames 180AT to 6900

Type CD

DIMENSIONS - For ESTIMATING ONLY unless endorsed for construction

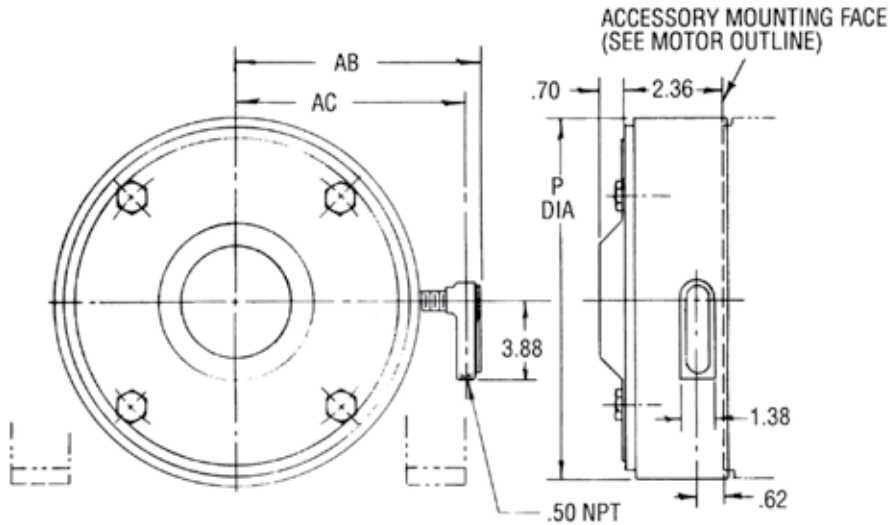

NOTES:

On frames CD180AT through CD320AT, the speed limit switch can be mounted with conduit on right or left side, but will be mounted on same side as machine leads unless otherwise specified. Providing mounting conditions permit, conduit may be turned so that entrance can be made in any direction.

On frames CD360AT through CD500AT, the speed limit switch can be mounted with conduit on right or left side, or top or bottom, but will be mounted on same side as machine leads unless otherwise specified. Providing mounting conditions permit, conduit may be turned so that entrance can be made in any direction.

FOR FRAMES
CD180AT - CD500AT
WEIGHT - 14 LB.

Frame	AB	AC	P
CD180AT	7.59	6.43	8.86
CD210AT Thru CD500AT	7.92	6.76	9.73

From 36A168434AC

Outline Dimensions

FOR FRAMES CD6000-CD6900

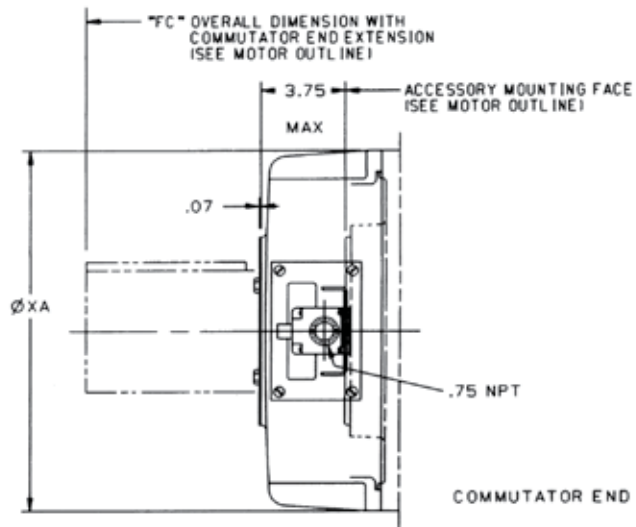
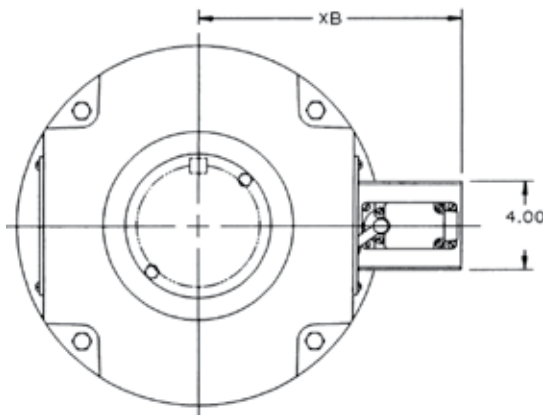

Frame	Approx. Net Wt. in Lbs.	XA	XB
CD6000	34	13.00	10.00
CD6100			
CD6200 Thru CD6900	50	16.25	11.75

Limit switch may be arranged for circuit opening or circuit closing or both.

Limit switch may be mounted on either side, but will be mounted on the same side as machine leads unless otherwise specified.

From 36C695008RA

Avtron Tachometer

Frames 180AT to 6900

Type CD

DIMENSIONS - For ESTIMATING ONLY unless endorsed for construction

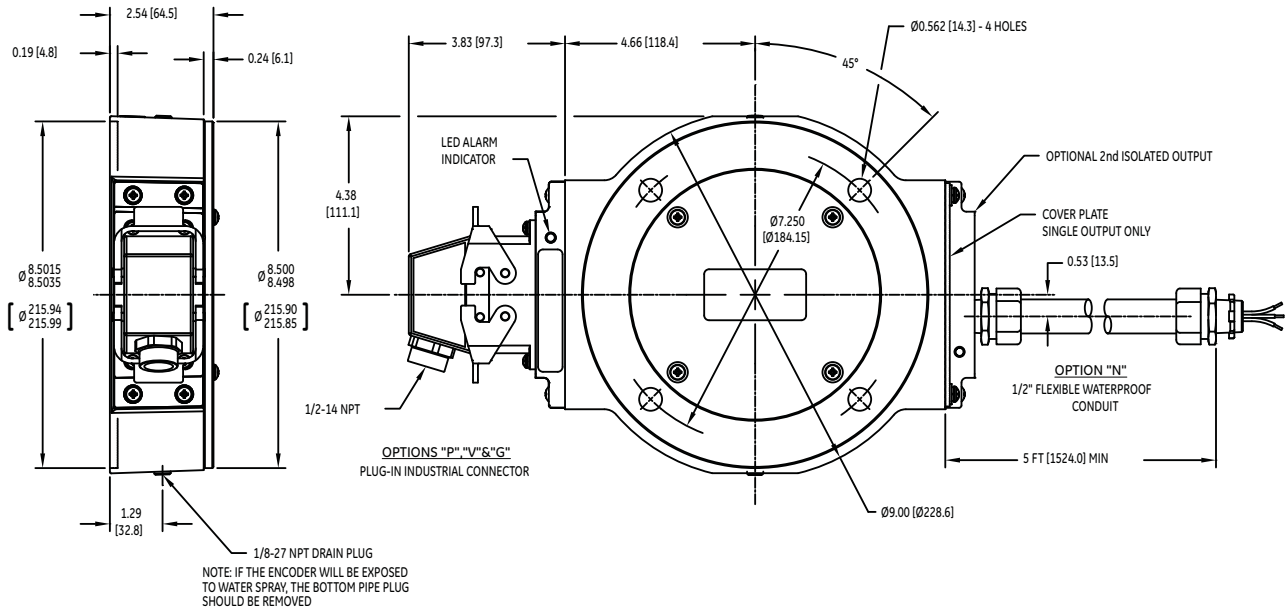

AVTRON AV850 SMARTach II™
WEIGHT — 9 LBS
FOR FRAMES CD180-CD6900

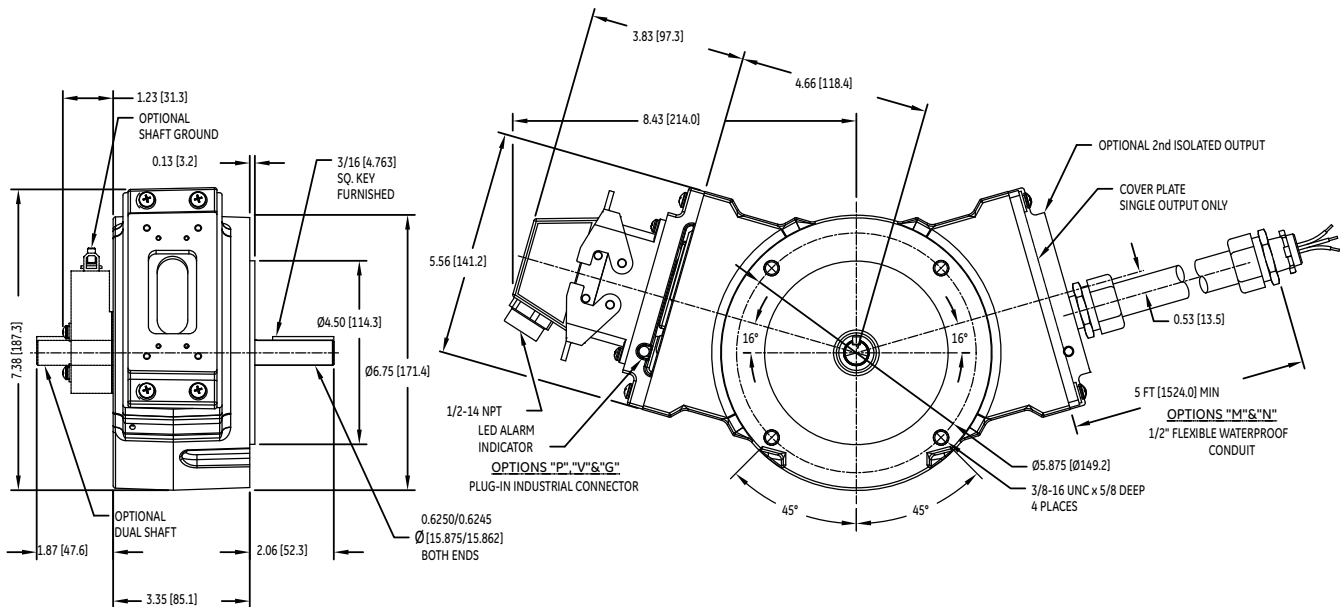

AVTRON AV485 SMARTach II™
WEIGHT — 11 LBS
FOR FRAMES CD180-CD6900

Outline Dimensions

Avtron Tachometer

Frames 180AT to 6900

Type CD

DIMENSIONS - For ESTIMATING ONLY unless endorsed for construction

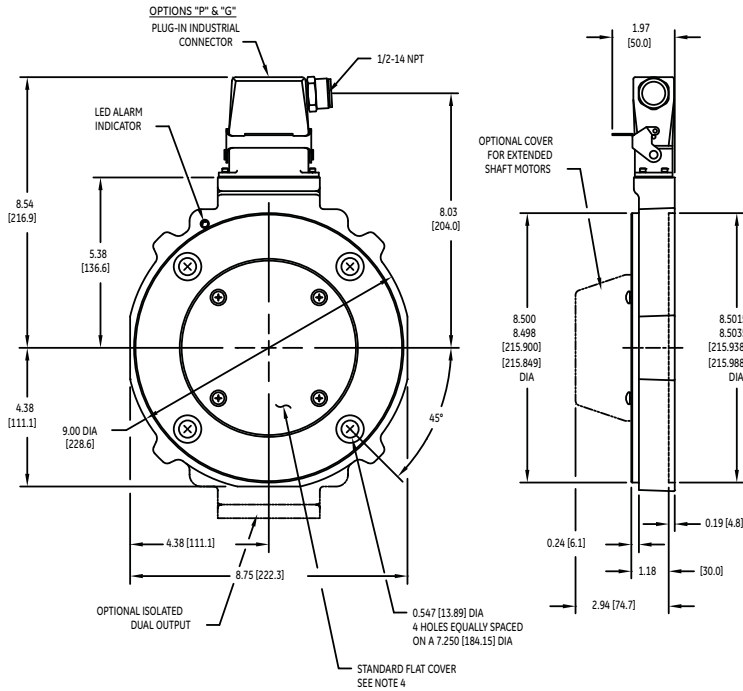

4 - STANDARD FLAT COVER SHOWN IN FRONT VIEW.
OPTIONAL THRU-SHAFT COVER NOT SHOWN.

AVTRON AV85 THIN-LINE II™
WEIGHT — 2.5 - 4 LBS
FOR FRAMES CD180 - CD6900

Outline Dimensions

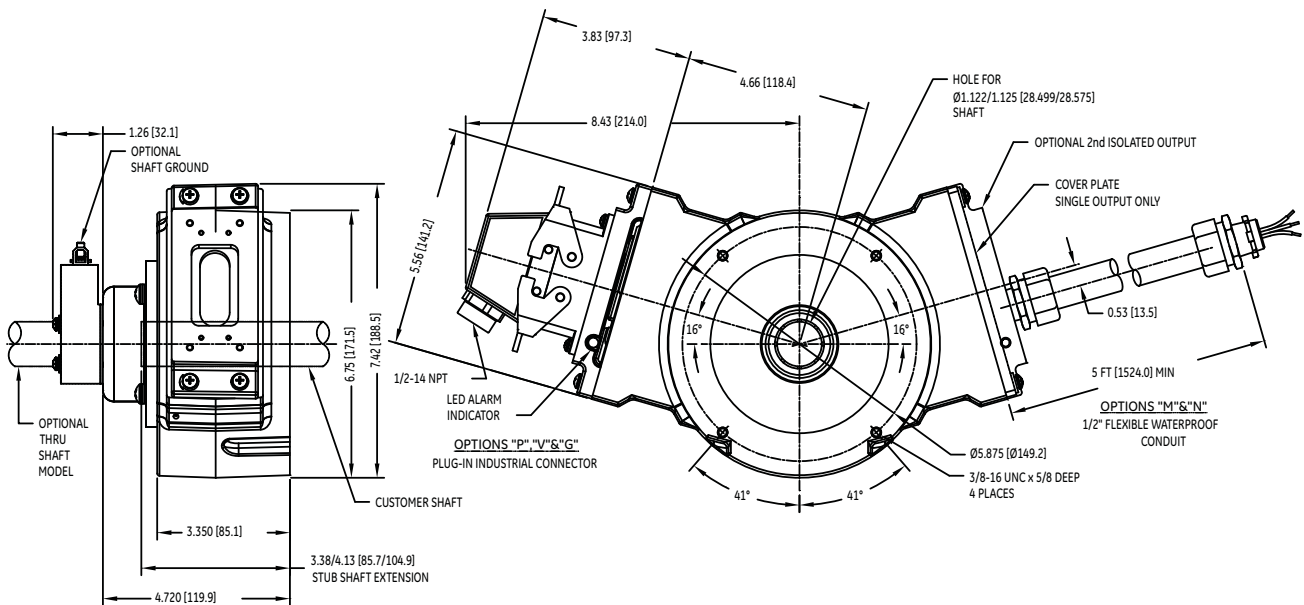

AVTRON AV685 SMARTach™ (HOLLOW SHAFT)
WEIGHT — 14 LBS
FOR FRAMES CD180 - CD6900

Type AN Tachometer

Frames 180AT to 6900

Type CD

DIMENSIONS - For ESTIMATING ONLY unless endorsed for construction

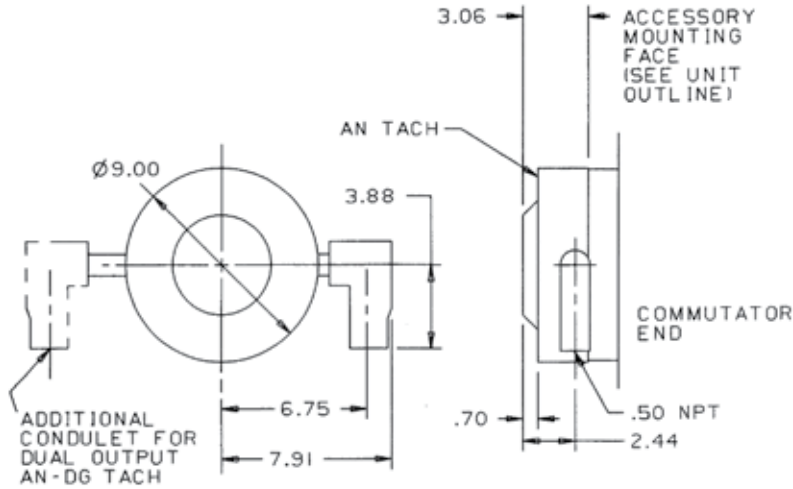

AN-AC
WEIGHT — 15 LB.

NOTES:

For frame sizes CD180AT through CD6900, the tachometer can be mounted with condulet on right or left side, top or bottom, but will be mounted on same side as machine leads unless otherwise specified. Providing mounting conditions permit, condulet may be turned so that entrance can be made in any direction.

From 36A180215AA

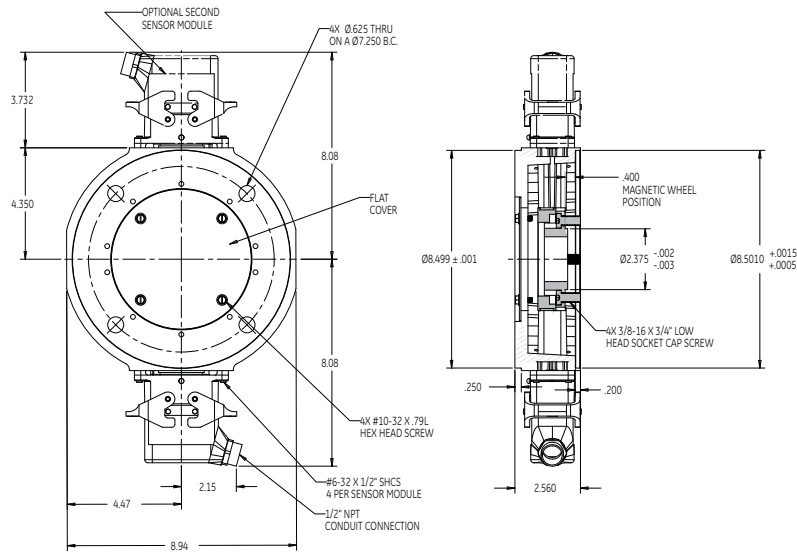

Outline Dimensions

Output	DIMENSIONS IN INCHES							
	Single				Dual			
PPR	A	B	C	D	A	B	C	D
240	12.22	7.64	7.11	—	15.28	7.64	7.11	14.21
600	12.78	8.21	7.67	—	16.41	8.21	7.67	15.34

NORTHSTAR RIM Tach® 8500 NexGen
AN-DG
WEIGHT — 15 LB.

From L79202-1

NorthStar Tachometer

Type CD

DIMENSIONS - For ESTIMATING ONLY unless endorsed for construction

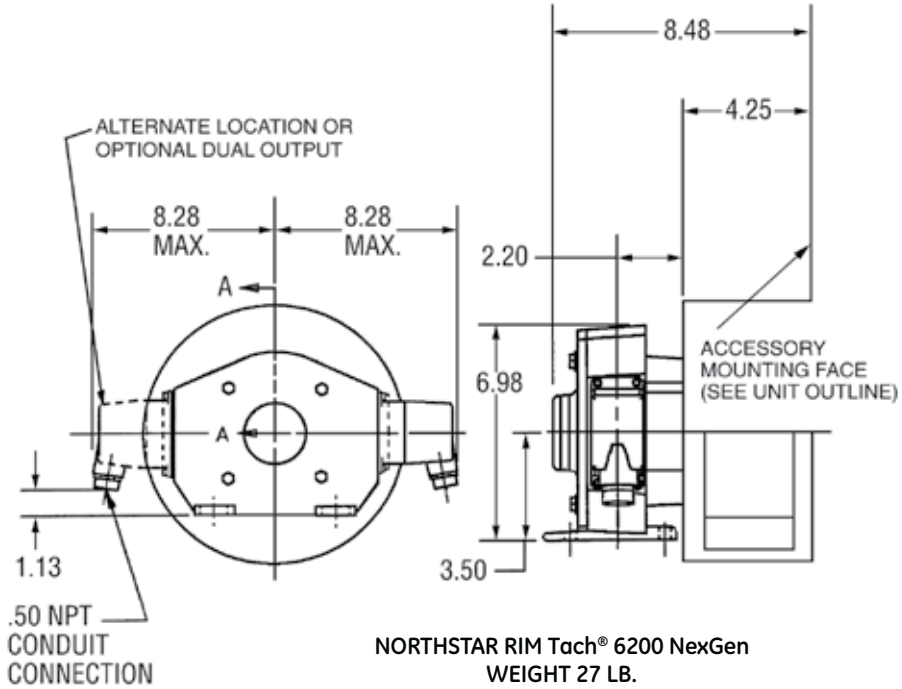

NORTHSTAR RIM Tach® 6200 NexGen
WEIGHT 27 LB.
FRAME CD180AT-CD6900

Outline Dimensions

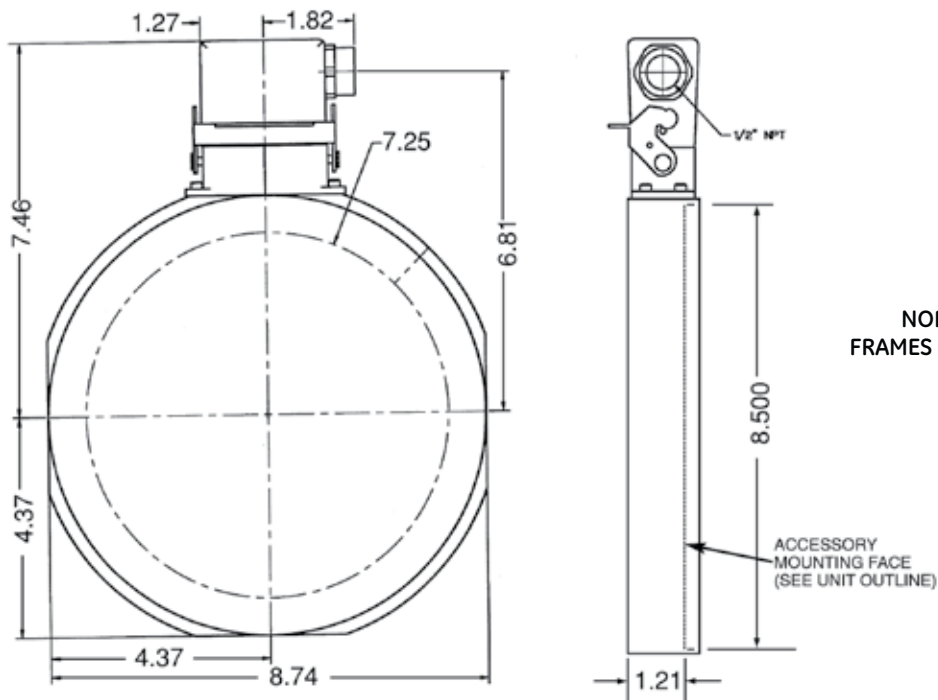

NORTHSTAR SL85
FRAMES CD180AT-CD500AT

NorthStar Tachometer

Frames CD180 to CD6900

Type CD

DIMENSIONS - For ESTIMATING ONLY unless endorsed for construction

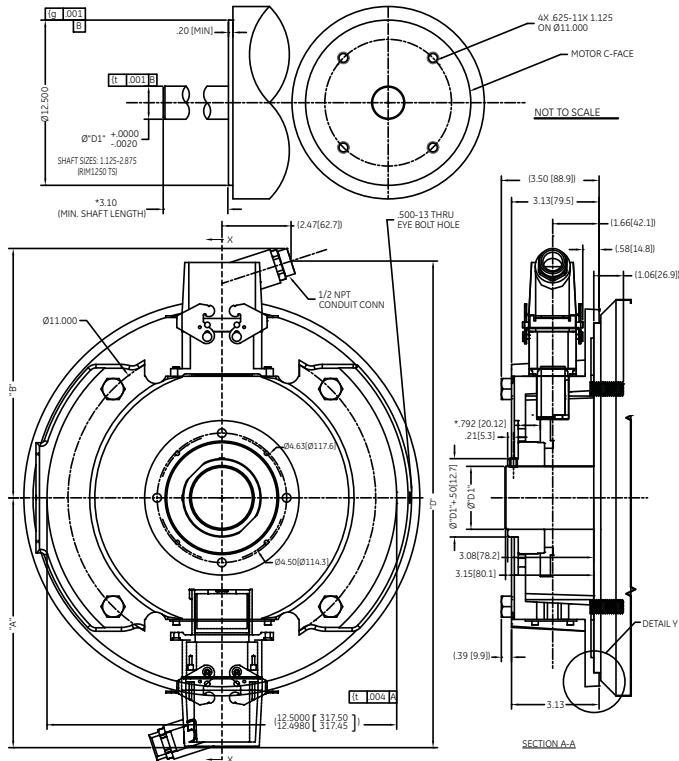

**NORTHSTAR RIM Tach® 1250 NexGen
FOR CD6000 FRAMES ONLY**

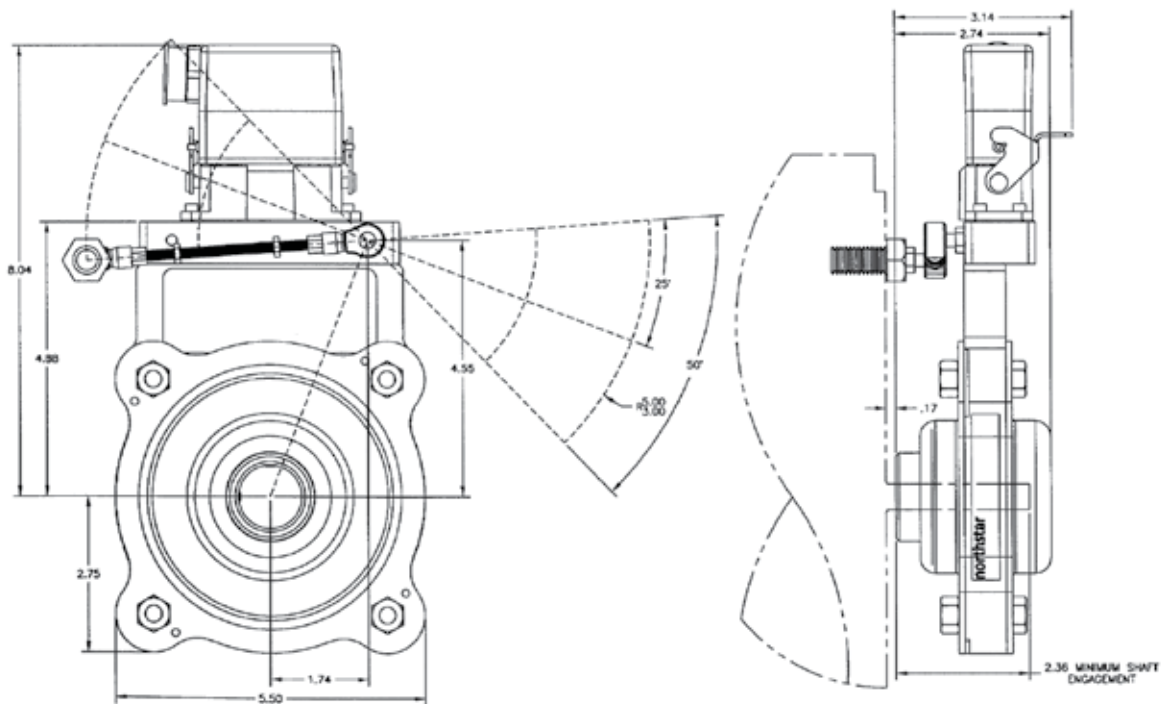

**NORTHSTAR SLIM Tach® HS56 HOLLOW SHAFT ENCODER
FOR FRAMES CD180 - CD6900**

Outline Dimensions

Dynapar Encoder

Frames CD180 to CD6900

Type CD

DIMENSIONS - For ESTIMATING ONLY unless endorsed for construction

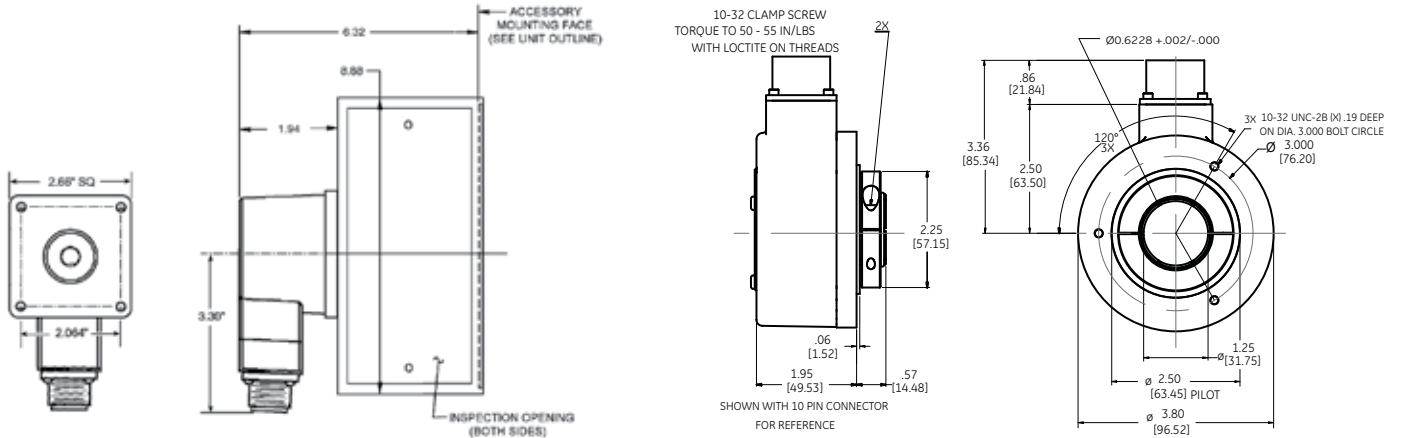

DYNAPAR HA625 ENCODER
FOR FRAMES CD180 - CD6900

DYNAPAR HS35R ENCODER
HOLLOW SHAFT — WEIGHT 16 OZ
FOR FRAMES CD180 - CD6900

Outline Dimensions

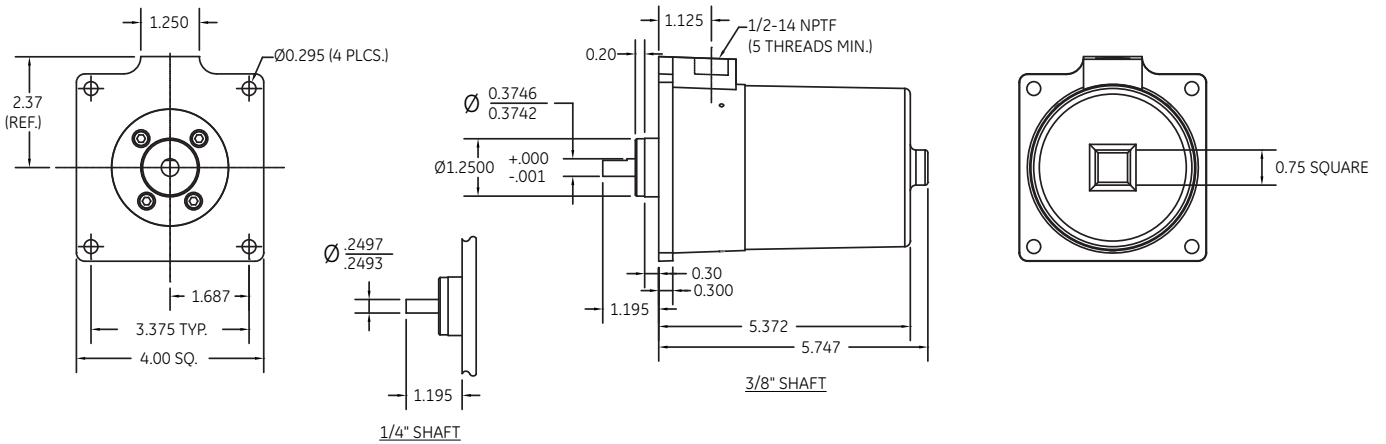

DYNAPAR X25 ENCODER
EXPLOSIONPROOF
WEIGHT — 4.5 LBS
FOR FRAMES CD180 - CD6900

Dynapar Rotopulser

Frames 180AT to 6900

Type CD

DIMENSIONS - For ESTIMATING ONLY unless endorsed for construction

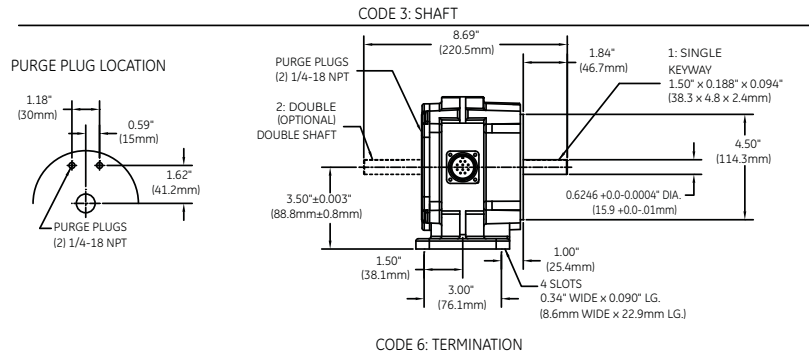

0,1: MS CONNECTORS

2,3: PLUGGABLE SCREW TERMINALS

CODE 4: FORMAT

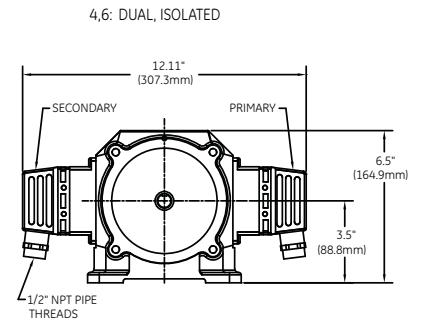
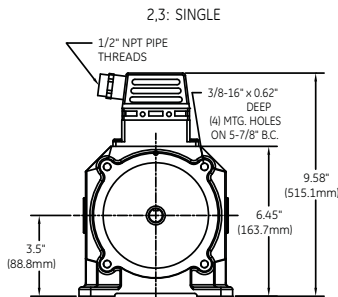
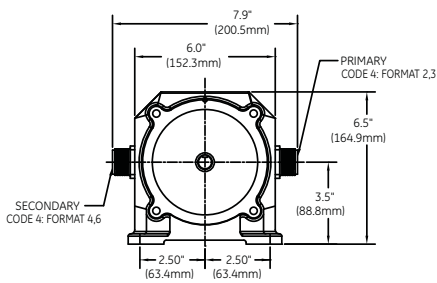

**DYNAPAR H56 ROTOPULSER
WEIGHT — 9 LBS
FOR FRAMES CD180 - CD6900**

Outline Dimensions

Excellon® Type BC Tachometer

Frames 180AT to 6900

Type CD

DIMENSIONS - For ESTIMATING ONLY unless endorsed for construction

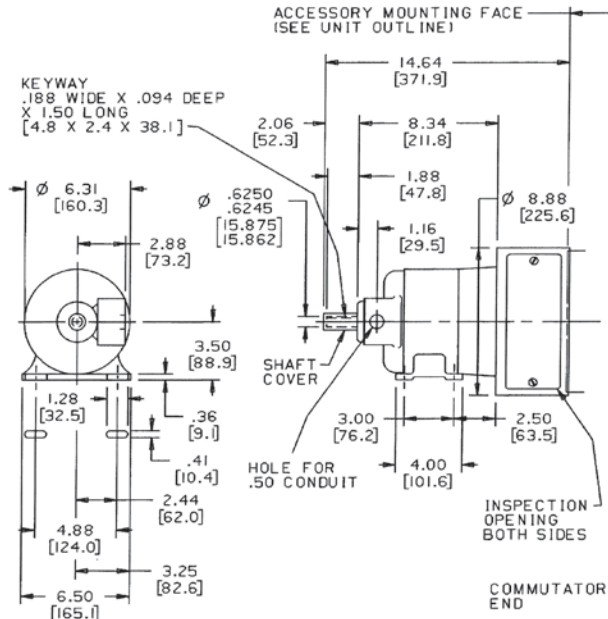

**FOR FRAMES CD180AT-CD6900
BC42
WEIGHT — 35 LB.**

From 36A180215AB

Outline Dimensions

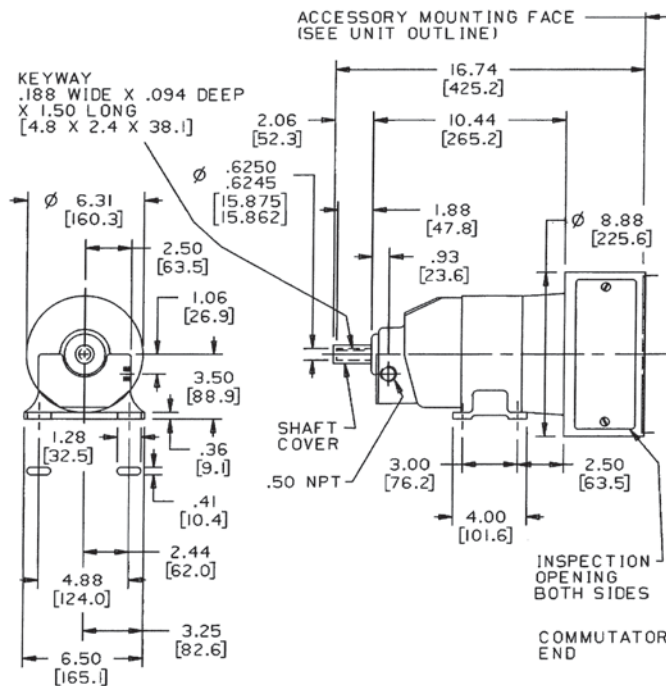

**FOR FRAMES CD180AT-CD6900
BC46
WEIGHT — 45 LB.**

From 36A180215AC

Excellon Form Y Tachometer

Frames 180AT to 6900

Type CD

DIMENSIONS - For ESTIMATING ONLY unless endorsed for construction

Model 5PY59EY is an AC tachometer generator for speed-indicating duty.

Model 5PY59JY is a DC tachometer generator for speed-regulating and/or speed-indicating duty.

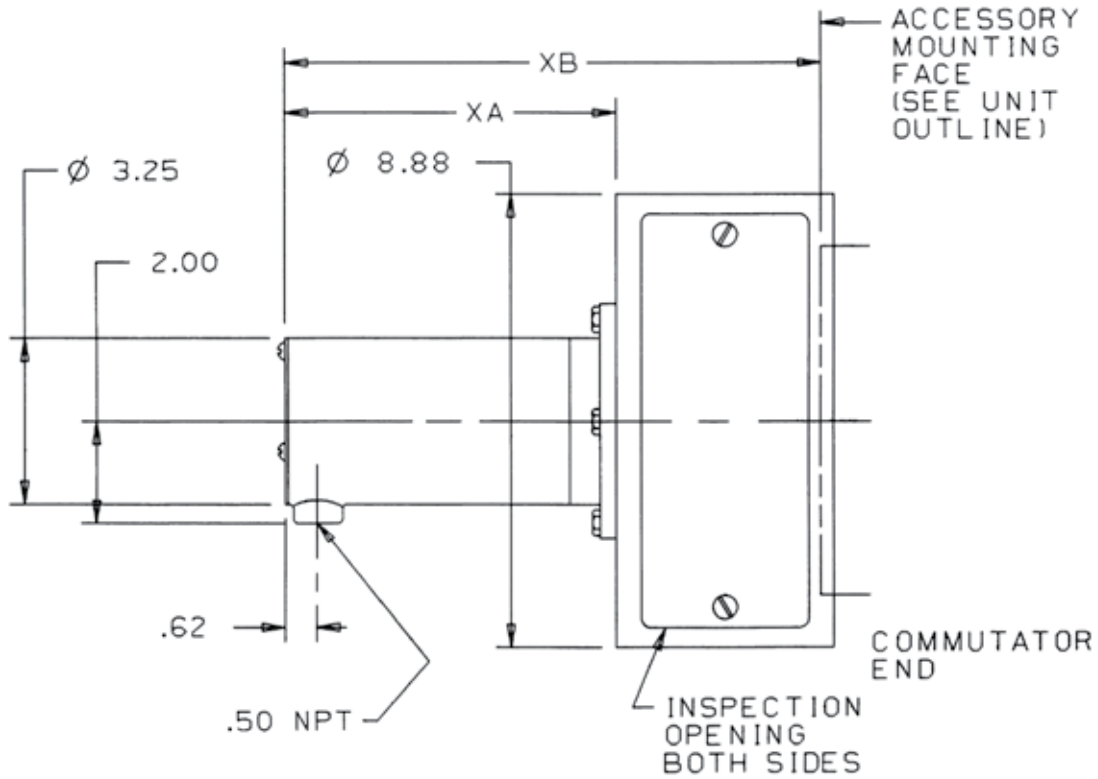

Type	XA	XB
5PY59EY	5.06	9.02
5PY59JY	6.50	10.46

FOR FRAMES CD180AT-CD6900
FORM Y
WEIGHT — 25 LB.

Outline Dimensions

From 36A180215AD

Sliding Base

Frames 180AT to 500AT

Horizontal Floor Mounting Only

Type CD

DIMENSIONS - For ESTIMATING ONLY unless endorsed for construction

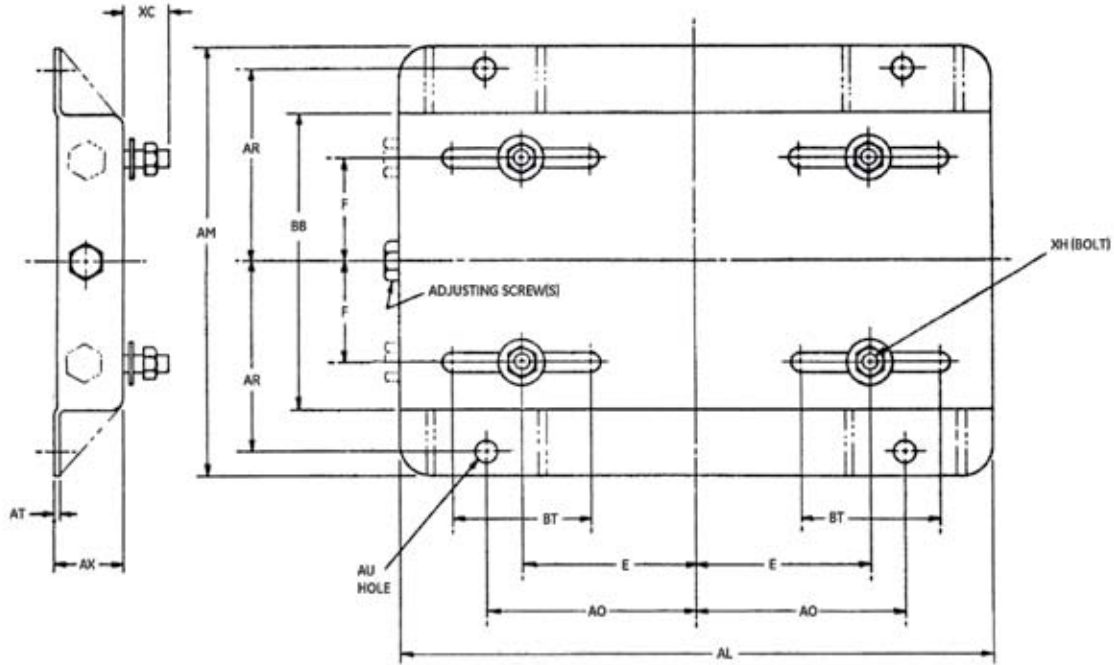

Outline Dimensions

Frame	Approx. Net Wt. in Lbs.	DIMENSIONS IN INCHES												
		BB	E	F	AL	AM	AO	AR	AT	AU	AX	BT	XH	XC
CD182AT	9.00	6.500	3.75	2.25	12.75	9.5000	4.50	4.250	0.1340	0.500	1.50	3.00	0.375 X 1.50	1.2500
CD186AT	11.0	9.000	3.75	3.50	12.75	12.000	4.50	5.500	0.1340	0.500	1.50	3.00	0.375 X 1.50	1.2500
CD189AT	14.0	12.00	3.75	5.00	12.75	15.000	4.50	7.000	0.1340	0.500	1.50	3.00	0.375 X 1.50	1.2500
CD218AT	17.0	12.00	4.25	5.00	15.00	15.500	5.25	7.000	0.1640	0.500	1.75	3.50	0.375 X 1.50	1.2500
CD219AT	21.5	13.00	4.25	5.50	15.00	16.500	5.25	7.500	0.1640	0.500	1.75	3.50	0.375 X 1.50	1.2500
CD2110AT	19.0	14.50	4.25	6.25	15.00	18.000	5.25	8.250	0.1640	0.500	1.75	3.50	0.375 X 1.50	1.2500
CD258AT	20.0	15.00	5.00	6.25	17.75	19.375	6.25	8.750	0.1875	0.625	2.00	4.00	0.500 X 1.75	1.4375
CD259AT	21.0	16.50	5.00	7.00	17.75	20.875	6.25	9.500	0.1875	0.625	2.00	4.00	0.500 X 1.75	1.4375
CD287AT	24.0	15.50	5.00	6.25	19.75	19.875	7.00	9.000	0.1875	0.625	2.00	4.50	0.500 X 2.00	1.6875
CD288AT	24.0	17.00	5.50	7.00	19.75	21.375	7.00	9.750	0.1875	0.625	2.00	4.50	0.500 X 2.00	1.6875
CD327AT	34.0	17.50	6.25	7.00	22.75	22.750	8.00	10.25	0.1875	0.750	2.50	5.25	0.625 X 2.50	2.1875
CD328AT	35.0	19.50	6.25	8.00	22.75	24.750	8.00	11.25	0.1875	0.750	2.50	5.25	0.625 X 2.50	2.1875
CD329AT	36.0	21.50	6.25	9.00	22.75	26.750	8.00	12.25	0.1875	0.750	2.50	5.25	0.625 X 2.50	2.1875
CD365AT*	45.0	16.50	7.00	6.12	25.50	21.500	9.00	9.620	0.2500	0.880	2.50	6.00	0.750 X 3.00	2.5000
CD366AT*	50.0	18.25	7.00	7.00	25.50	23.250	9.00	10.50	0.2500	0.880	2.50	6.00	0.750 X 3.00	2.5000
CD368AT*	60.0	22.25	7.00	9.00	25.50	27.250	9.00	12.50	0.2500	0.880	2.50	6.00	0.750 X 3.00	2.5000
CD407AT*	64.0	22.25	8.00	9.00	28.75	28.125	10.0	12.75	0.2500	1.000	3.00	7.00	0.875 X 3.50	3.0000
CD409AT*	70.0	26.25	8.00	11.0	28.75	32.125	10.0	14.75	0.2500	1.000	3.00	7.00	0.875 X 3.50	3.0000
CD504AT*	132	20.75	10.0	8.00	35.00	28.000	12.5	12.50	0.3125	1.250	3.50	8.00	1.125 X 3.50	3.0000
CD506AT*	138	24.75	10.0	10.0	35.00	32.000	12.5	14.50	0.3125	1.250	3.50	8.00	1.125 X 3.50	3.0000
CD508AT*	146	29.75	10.0	12.5	35.00	37.000	12.5	17.00	0.3125	1.250	3.50	8.00	1.125 X 3.50	3.0000

*These frames have two adjusting screws and eight gussets shown in phantom.

From 533C230AC

Soleplates

Frames CD210AT to CD500AT

Type CD

DIMENSIONS - For ESTIMATING ONLY unless endorsed for construction

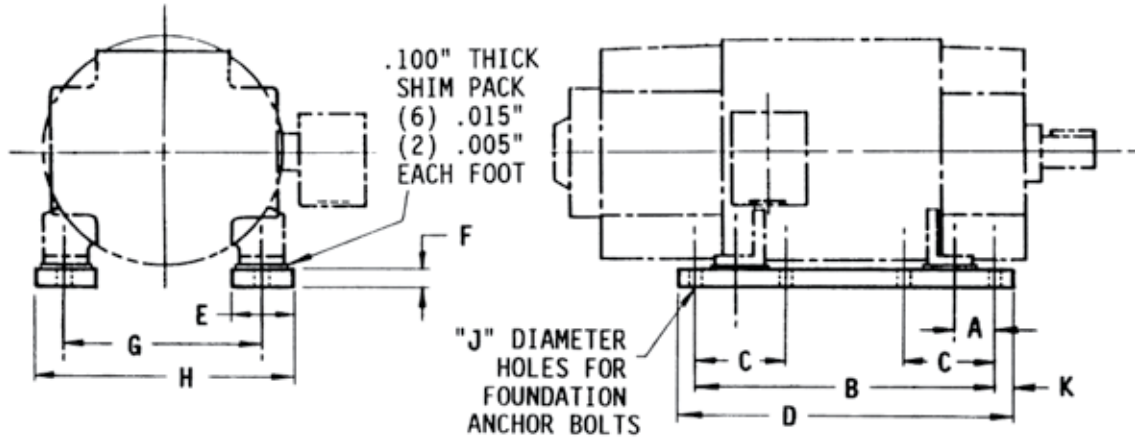

Frame	DIMENSIONS IN INCHES											
	A	B	C	D	E	F	G	H	J	K	L	M
CD218AT	1.62	13.25	OMIT	15.00	3	0.88	8.50	11.5	0.56	0.88	6.230	1.5
CD219AT	1.62	14.25	OMIT	16.00	3	0.88	8.50	11.5	0.56	0.88	6.230	1.5
CD2110AT	1.62	15.75	OMIT	17.50	3	0.88	8.50	11.5	0.56	0.88	6.230	1.5
CD258AT	2.00	16.50	OMIT	18.50	4	1.12	10.0	14.0	0.69	1.00	7.470	2.0
CD259AT	2.00	18.00	OMIT	20.00	4	1.12	10.0	14.0	0.69	1.00	7.470	2.0
CD287AT	2.00	16.50	OMIT	18.50	4	1.12	11.0	15.0	0.69	1.00	8.220	2.0
CD288AT	2.00	18.00	OMIT	20.00	4	1.12	11.0	15.0	0.69	1.00	8.220	2.0
CD327AT	2.25	18.50	OMIT	21.00	4	1.38	12.5	16.5	0.81	1.25	9.480	2.0
CD328AT	2.25	20.50	OMIT	23.00	4	1.38	12.5	16.5	0.81	1.25	9.480	2.0
CD329AT	2.25	22.50	OMIT	25.00	4	1.38	12.5	16.5	0.81	1.25	9.480	2.0
CD365AT	2.25	16.75	OMIT	19.75	5	1.38	14.0	19.0	1.00	1.50	10.48	2.5
CD366AT	2.25	18.50	OMIT	21.50	5	1.38	14.0	19.0	1.00	1.50	10.48	2.5
CD368AT	2.25	22.50	7	25.50	5	1.38	14.0	19.0	1.00	1.50	10.48	2.5
CD3610AT	2.25	26.50	7	29.50	5	1.38	14.0	19.0	1.00	1.50	10.48	2.5
CD2612AT	2.25	32.50	7	35.50	5	1.38	14.0	19.0	1.00	1.50	10.48	2.5
CD407AT	2.75	23.50	8	26.75	6	1.88	16.0	22.0	1.12	1.62	11.98	3.0
CD409AT	2.75	27.50	8	30.75	6	1.88	16.0	22.0	1.12	1.62	11.98	3.0
CD4012AT	2.75	37.50	8	40.75	6	1.88	16.0	22.0	1.12	1.62	11.98	3.0
CD504AT	3.25	22.50	8	26.50	6	1.88	20.0	26.0	1.38	2.00	14.48	3.0
CD506AT	3.25	26.50	9	30.50	6	1.88	20.0	26.0	1.38	2.00	14.48	3.0
CD508AT	3.25	31.50	9	35.50	6	1.88	20.0	26.0	1.38	2.00	14.48	3.0
CD5010AY	3.25	38.50	9	42.50	6	1.88	20.0	26.0	1.38	2.00	14.48	3.0

NOTE: Motors are shipped with sole plates bolted to motor feet. Shims are included. Motor and sole plates will be installed as a unit. Sole plates will not be removed from motor and installed separately.

Outline Dimensions

From 36A167263CA

Soleplates

Frames CD6050 to CD6280

Type CD

DIMENSIONS - For ESTIMATING ONLY unless endorsed for construction

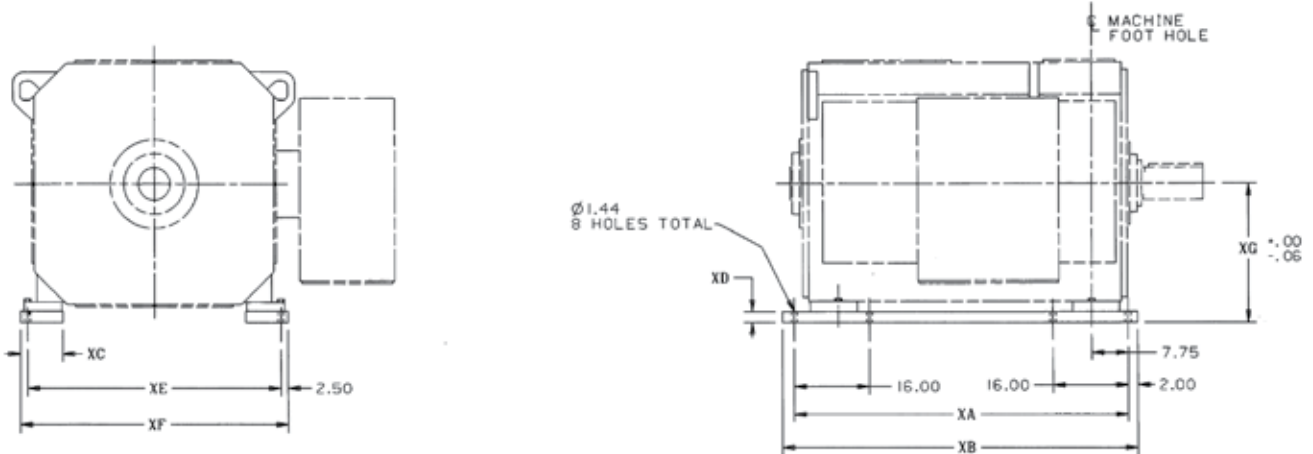

Outline Dimensions

Frame	Approx. Net Wt. in Lbs.	XA	XB	XC	XD	XE	XF	XG
CD6050	412	48.0	52.0	7	2.00	30	35	16.62
CD6052	428	50.0	54.0	7	2.00	30	35	16.62
CD6054, 6055	444	52.0	56.0	7	2.00	30	35	16.62
CD6057	460	54.0	58.0	7	2.00	30	35	16.62
CD6058, 6059	476	56.0	60.0	7	2.00	30	35	16.62
CD6062, 6063	508	60.0	64.0	7	2.00	30	35	16.62
CD6066	539	64.0	68.0	7	2.00	30	35	16.62
CD6154	444	52.0	56.0	7	2.00	35	40	19.12
CD6157	460	54.0	58.0	7	2.00	35	40	19.12
CD6160	476	58.0	62.0	7	2.00	35	40	19.12
CD6163	508	60.0	64.0	7	2.00	35	40	19.12
CD6164	523	62.0	66.0	7	2.00	35	40	19.12
CD6165	539	64.0	68.0	7	2.00	35	40	19.12
CD6168, 6169	555	66.0	70.0	7	2.00	35	40	19.12
CD6173	587	70.0	74.0	7	2.00	35	40	19.12
CD6177	626	75.0	79.0	7	2.00	35	40	19.12
CD6259	617	56.5	60.5	8	2.25	42	47	23.37
CD6262	647	59.5	63.5	8	2.25	42	47	23.37
CD6266, 6268	703	65.0	69.0	8	2.25	42	47	23.37
CD6270, 6271	739	68.5	72.5	8	2.25	42	47	23.37
CD6275	780	72.5	76.5	8	2.25	42	47	23.37
CD6280	831	77.5	81.5	8	2.25	42	47	23.37

Soleplates

Frames CD6766 to CD6999

Type CD

DIMENSIONS - For ESTIMATING ONLY unless endorsed for construction

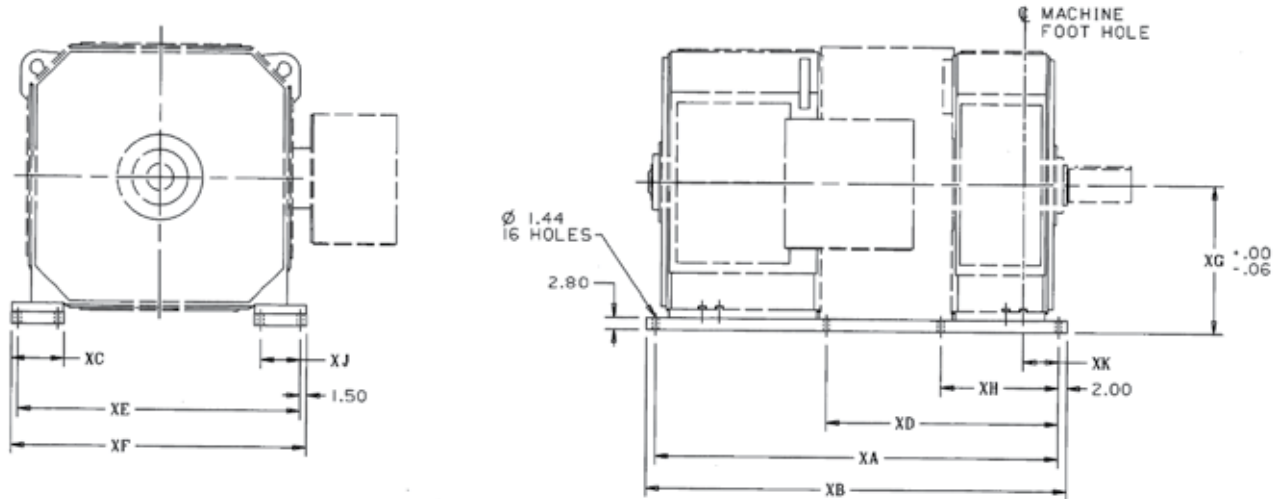

Frame	Approx. Net Wt. in Lbs.	XA	XB	XC	XD	XE	XF	XG	XH	XJ	XK
CD6766	834.0	64.60	68.620	7.500	32.9	42.46	45.46	27.12	21.7	4.50	7.75
CD6770	876.0	68.10	72.120	7.500	36.4	42.46	45.46	27.12	21.7	4.50	7.75
CD6771	886.0	66.90	72.940	7.500	32.9	42.46	45.46	27.12	21.7	4.50	7.75
CD6774	924.0	72.10	76.120	7.500	40.4	42.46	45.46	27.12	21.7	4.50	7.75
CD6776	926.0	72.40	76.440	7.500	36.4	42.46	45.46	27.12	21.7	4.50	7.75
CD6778	974.0	76.40	80.440	7.500	40.4	42.46	45.46	27.12	21.7	4.50	7.75
CD6779	982.0	77.10	81.120	7.500	45.4	42.46	45.46	27.12	21.7	4.50	7.75
CD6785	1034	81.40	85.440	7.500	45.4	42.46	45.46	27.12	21.7	4.50	7.75
CD6873	1466	71.22	75.250	12.00	42.5	54.20	57.20	30.12	27.0	9.00	8.30
CD6876	1542	75.22	79.250	12.00	46.5	54.20	57.20	30.12	27.0	9.00	8.30
CD6881	1628	79.72	83.750	12.00	51.0	54.20	57.20	30.12	27.0	9.00	8.30
CD6882	1630	79.82	83.810	12.00	42.5	54.20	57.20	30.12	27.0	9.00	8.30
CD6885	1706	83.82	87.810	12.00	46.5	54.20	57.20	30.12	27.0	9.00	8.30
CD6887	1732	85.22	89.250	12.00	56.5	54.20	57.20	30.12	27.0	9.00	8.30
CD6890	1792	88.32	92.310	12.00	51.0	54.20	57.20	30.12	27.0	9.00	8.30
CD6896	1896	93.82	97.810	12.00	56.5	54.20	57.20	30.12	27.0	9.00	8.30
CD6977	1594	76.60	80.620	12.25	44.2	54.20	68.98	35.12	27.5	9.25	8.25
CD6981	1672	80.60	84.620	12.25	48.2	65.98	68.98	35.12	27.5	9.25	8.25
CD6985	1768	85.60	89.620	12.25	53.2	65.98	68.98	35.12	27.5	9.25	8.25
CD6986	1760	85.20	89.180	12.25	44.2	65.98	68.98	35.12	27.5	9.25	8.25
CD6990	1836	89.20	93.180	12.25	48.2	65.98	68.98	35.12	27.5	9.25	8.25
CD6991	1894	92.10	96.120	12.25	59.7	65.98	68.98	35.12	27.5	9.25	8.25
CD6996	1934	94.20	98.180	12.25	53.2	65.98	68.98	35.12	27.5	9.25	8.25
CD6999	2060	100.7	104.68	12.25	59.7	65.98	68.98	35.12	27.5	9.25	8.25

Outline Dimensions

NEMA Mounting Configurations

Type CD

DIMENSIONS - For ESTIMATING ONLY unless endorsed for construction

FLOOR MOUNTINGS

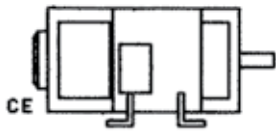

ASSEMBLY F-1

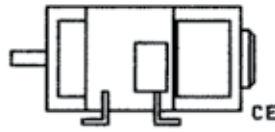

ASSEMBLY F-2

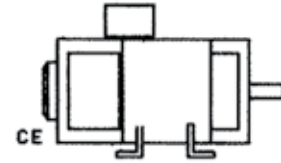

ASSEMBLY F-3

WALL MOUNTINGS

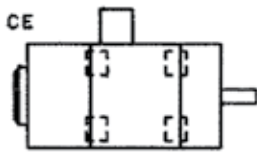

ASSEMBLY W-1

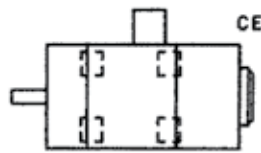

ASSEMBLY W-2

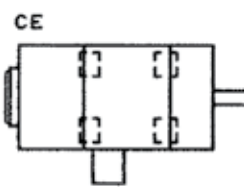

ASSEMBLY W-3

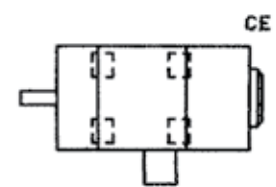

ASSEMBLY W-4

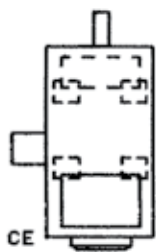

ASSEMBLY W-5

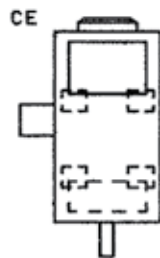

ASSEMBLY W-6

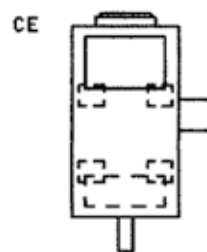

ASSEMBLY W-7

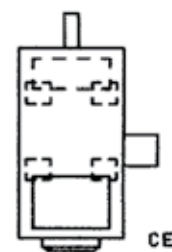

ASSEMBLY W-8

CEILING MOUNTINGS

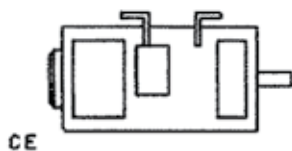

ASSEMBLY C-1

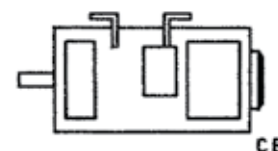

ASSEMBLY C-2

Application Information

Index

	Page
Air Flow Requirements for Separately Ventilated Motors	5.13
Air Supply Quality Guidelines	5.4
Ambient Conditions	5.5
Armature Current, Rate of Change	5.2
Audio Noise	5.10
Bearing Life	5.5
Bearing Life Factor vs. Speed.	5.6
Bearing Life (L10) Curves	5.8
Bearing Life Speed vs. Load.	5.7
Blower Data for Blower Ventilated Motors.	5.14
Blower Data for TEAAC and TEWAC Motors	5.15
Direction of Rotation	5.5
Environmental Effect on Brushes	5.5
Environmental Effects on Insulation	5.4
Maximum Momentary Overload.	5.2
Motor Fields	5.2
Motor Load Characteristics.	5.16
Performance.	5.5
Pinion Drives.	5.6
Power Supplies	5.10
Safety	5.2
Special Load Considerations	5.6
Speed Range by Armature Control	5.5
Speed Variation	5.2
Standard Constant Torque Range.	5.3
Standard Field Voltages and Connections.	5.2
Starting Current.	5.2
Thrust Loads.	5.6
V-Belt Drives.	5.5

Application Information

CD180AT-CD6900 Frames

General Information

All motors are furnished with reconnectable fields as listed in the tabulation below:

STANDARD FIELD VOLTAGES AND CONNECTIONS			
Armature Voltage	Field Voltage Reconnectable	Field Voltage When Connected 1 Circuit (Series)	Field Voltage When Connected 2 Circuit (Parallel)
500 or 240	300/150 240/120	300 240	150 120
180	200/100	200	100

Speed Vibration

- $\pm 7.5\%$ at rated armature voltage and field current
- Not to exceed 15% full load (cold) to full load (hot) — ventilated
- Not to exceed 20% full load (cold) to full load (hot) — totally enclosed

Miscellaneous

- Torque = $\frac{\text{HP} \times 5252}{\text{Base Speed}}$
- Air Rise = Air exhaust temperature minus air intake temperature in degrees C (25 degrees C is considered high)

Starting Current

Standard motors permit 250% full load current for momentary starting duty on frames CDL182AT-CD5010AY and 300% on frames CD6000-CD6900.

Maximum Momentary Overload

Standard continuously rated motors rated 3/4 HP per RPM and less will carry 150% full load current for a period of one minute throughout the rated speed range and are suitable for higher current peaks below rated top speed. (Refer to page 3.17 of this publication.)

Motor Fields

Standard motors in frames CDL182AT-CD5010AY and all ratings in the CD6000-CD6900 frames are shunt wound.

Rate of Change of Armature Current

Motors in frames CD6000-CD6200 are suitable for a rate of change of armature current of 11 per unit per second.

Motors in frames CD6700-CD6900 are suitable for 22 per unit per second change in armature current. Contact **Wolong** for information if higher rates are needed.

Safety

The material in this publication should be used with due regard to the hazards to personnel resulting from the use and application of electric motors and generators.

Personnel Protection

Consideration should be given to the type of personnel who would normally come in close contact with motors and generators. Equipment installed in locations open to the general public should be better protected than those located in areas available only to qualified personnel, who should recognize any potential hazard involved in the use of the equipment.

It is strongly recommended that the user become familiar with the NEMA Publication MG2-2001 (Rev 1-2007), "Safety Standard and Guide for the Selection, Installation, and Use of Electric Motors and Generators."

Electrical Shocks

Higher direct current motor voltages are now common due to the use of rectified AC power supplies, and the danger of shock is substantially increased. Rectified 460 (RMS) AC volt power results in about 500 or more volts DC. Overall safety can be improved by:

1. Specifying that frames of rotating machines be solidly grounded in accordance with the National Electrical Code and consistent with sound local practices. Because paint insulates, foot or flange bolts cannot be counted on to provide a satisfactory ground. Standard motors are provided with a brass screw and symbol inside or adjacent to the conduit box.
2. Specifying a dripproof fully guarded enclosure as a minimum. This will decrease the danger to personnel from contact with the brush rigging and commutator.
3. Specifying manual reset for overcurrent and overtemperature protection. Automatic reset allows resetting at an unsafe time.
4. Specifying circuitry as far as possible, which prevents access to live motor parts, unless power is removed from the armature and main field. For silicon-controlled rectified drives, the AC lines into the rectifier should be opened before maintenance work is performed on the motor.

Mechanical Protection

Mechanical hazards to personnel occur due to overspeed, exposure to rotating parts, mechanical overloading of shafts or bearings, and failure of lifting devices. GE motors are designed so that, in an emergency, they will withstand an overspeed in accordance with the table on the following page:

Application Information

CD180AT-CD6900 Frames

Type of Motor	Maximum Monetary Overspeed
Shunt	25 percent above the maximum nameplate speed or 15 percent above the corresponding no-load speed, whichever is greater.
Compound with speed regulation of 35 percent or less	Not greater than 50 percent above full load base speed.

All DC motors may be subject to potentially dangerous overspeeding under certain conditions of misoperation.

Overspeeding of a DC compound wound or shunt wound motor may occur if the shunt field circuit becomes de-energized.

Unless the speed is inherently limited by the application of the motor, DC motors should be protected against dangerous overspeed by overspeed devices, field loss relays, or other means.

Motors can overspeed due to improper wiring during installation. Installation and instruction books contain statements and instructions to guard against such overspeed due to wrong initial connections.

Specifications should require that guards be placed over exposed couplings, pulleys, pinions, and unused shaft extensions for the protection of the operating personnel.

Care should be exercised in the selection of couplings, belts, or pinions with due consideration given to shock loads, overloads, and pulley pitch diameters. See page 5.7 for bearing life and allowable shaft loading. Too small a pulley diameter will require excessive belt tension to prevent belt slippage. This, in turn, overloads the bearings and shafts which may result in bearing and/or shaft failure, and possible overspeeding of the motor.

Additional coverage of the hazards in handling the rotating equipment covered in this publication may be found in the instruction books sent out with the equipment.

Hazards Due To Environment

Motors which operate in explosive atmospheres must meet the requirements of Articles 501-8 or 502-8 of the National Electrical Code. The Code assigns authority to approve the installation to "the authority having jurisdiction" (see Article 100 — Definitions of the NEC).

Motors approved by U.L. for Class I, Group D or Class II, Groups E, F, and G are available in some ratings. However, it is the responsibility of the customer to be familiar with the NEC and the local jurisdictional requirements and to determine that the motor selection (including possibly permissible alternatives to U.L. approved motors) is "acceptable to the authority having jurisdiction."

Insulation

Insulation life is dependent on many factors. Insulation failure results from either chemical or mechanical degradation or a combination of both. Chemical degradation is a function of the time and temperature at which the insulation is operated relative to its temperature rating. Roughly, a machine operated at the nominal temperature rating will operate twice as long as a machine operated 10°C higher. Chemical degradation can also be accelerated, if the machine operates in dirty or chemical atmospheres or in atmospheres of high moisture content. Mechanical degradation occurs when the conductors are subject to high forces. These forces may cause coil movement, which eventually can abrade the turn insulation on the wire or break the ground insulation.

Motor Heating

Cooling air for dripproof fully guarded self-ventilated, and totally enclosed fan cooled direct current motors is provided by shaft-driven fans.

At low operating speeds, the flow of ventilating air passing through the machine is reduced resulting in a decreased heat dissipation rate. Consequently, it becomes necessary to analyze the motor thermal capacities at each speed and load condition. In general, motors of dripproof fully guarded, self-ventilated, and totally enclosed fan cooled enclosures must be operated above 60% of the motor base speed to ensure proper cooling.

Motor Enclosure	Standard Constant Torque
Self-Ventilated	60% of base speed
Blower Ventilated	5%
Separately Ventilated	5%
TENV	5%
TEFC	60%
TEAO	40%
TEAAC	5%
TEWAC	5%

Motors ventilated from a separate source are supplied with a constant flow of cooling air, which is independent of the motor operating speed. A constant supply of cooling air permits much lower speed operation of a separately ventilated motor at rated torque without exceeding a maximum allowable temperature rise.

Continued operation at high temperature will significantly reduce insulation life. However, generally most applications have compensating periods of operation at some temperature lower than normal so that the use of the higher current for many applications is justified.

Application Information

CD180AT-CD6900 Frames

The exciting fields on all continuously rated, dripproof fully guarded blower ventilated and separately ventilated, and totally enclosed nonventilated motors are designed for continuous excitation at field voltages up to 105% of the rated value while the motor is operating at any speed and load within the capability of the armature. Temperatures under these conditions will not exceed maximum allowable. However, insulation life will be shortened, particularly during prolonged operation at low speed.

CAUTION:

Motor Field Heating — Unless specifically ordered, motors are NOT capable of continuous standstill excitation at rated field current. When the motor is shut down for more than 15 minutes, one of the following options must be used:

1. De-energize the field completely
2. Use field economy relays to limit the field current to a maximum of 50% of the nameplate rating
3. When applicable, fields may remain fully energized if the motor ventilation system (blower or customer duct) remains in operation.

Environmental Effects On Insulation

The insulation system used on GE DC motors is adequate for use in humid atmospheres. Acids, alkalies, abrasive dust, conducting dust, etc., when present, impose a severe hardship on the insulation system. Special consideration is required to determine the acceptability of a dripproof fully guarded enclosure, since the contamination itself may conduct shorting or grounding current over the insulation. This current gradually develops a permanent creepage path which can cause failure. The exposed uninsulated circuits on DC machines, such as the commutator brush rigging and bolted connections, allow early electrical failure when the enclosure is inadequate, regardless of the insulation system. Extra varnish dips will not correct this problem. An adequate enclosure should be used.

Where contamination is expected, a study of the history of the application should be made to determine what degree of protection has been successful in the past. A standard dripproof fully guarded machine can often be applied successfully, but a totally enclosed machine will provide extra reliability.

Air Supply Quality Guidelines

Cooling air quality can have an effect on machine performance. Nonconducting contaminants such as cement dust, dirt, sand, and sawdust can promote overtemperature by restricting cooling passages and air circulation. Abrasive materials may erode insulations within the machine. Conductive contaminants such as carbon dust, metal particles, and salt can also provide shorting paths to ground. Periodic “blowing out” or vacuuming of dust accumulation will tend to avoid major problems if oil, grease, or other liquids are allowed to enter the machine, contaminants will “stick” to insulating surfaces and make effective cleaning difficult.

Corrosive gases in applications such as papermills can have an extreme effect on machine performance and service life. Chlorine, hydrogen sulfide, and sulphur dioxide can damage commutator copper, hardware, and varnish systems. On the commutator, severe contamination will cause unprotected copper (where the brushes don't contact) to oxidize and turn bluish-gray developing scale that can bridge across insulating mica and cause commutation distress and possibly a flashover. Contamination produces high friction and uneven film which reduces brush life. Sparking may result from poor, uneven, or non-conductive commutator film which can lead to bar etching and further commutator surface erosion.

If high corrosion is suspect, air sampling coupons can be placed in the cooling air to determine corrosion rates. Field experience has shown that corrosion rates of motor cooling air should be below .5 microns/year to limit corrosion damage effects. Air sampling coupons and analysis are commercially available. Periodic seater stone application can prevent buildup and uneven commutator filming.

With high corrosion evident, further analysis can pinpoint the type of gases present. Elimination of high levels of gas can be made by relocating air inlets to other rooms or areas or simply raising an inlet off of a wet floor or away from open gutter-type drains. Additional filtering means such as charcoal filters can further improve air quality.

Effects of Radiation

Radiation can cause insulation degradation, if present in sufficient amounts. Where motors are exposed to the more common types of atomic radiation, nearly all standard insulations may be used if the radiation is below 10^7 Roentgens. Where radiation exceeds this value, specific information should be included in the requisition, proposition, or specifications.

Application Information

CD180AT-CD6900 Frames

Environmental Effects On Brushes

Brush Wear Caused by Silicone

WARNING:

The presence of silicone in DC Motors, particularly totally enclosed constructions, will cause rapid brush wear. Sources of silicone include oils, RTV compounds, mold release agents, and some insulating varnishes. These silicone substances must be avoided to ensure proper DC motor performance.

Speed Range By Armature Control

Standard motors are suitable for reduced speed operation by adjustable armature voltage. Some torque de-rating may be necessary for applications requiring extended periods of low-speed operation. For specific duty cycles contact **Wolong**.

Ambient Conditions

Standard Kinamatic™ drip-proof fully guarded and totally enclosed motors are designed for operation in a 40°C ambient temperature and at altitudes up to 3,300 feet above sea level.

Direction of Rotation

Motors in frame sizes CDL182AT-CD5010AY are suitable for continuous rotation in either direction or for reversing duty. Motors in frame sizes CD6000-CD6900 are suitable for continuous operation in the rotation specified on the nameplate for reversing duty. Motors in all frame sizes are generally suitable for continuous rotation in either direction or for reversing duty. In frame sizes CD6000-CD6900 applications in contaminated environments require that brushes be trailing for the desired rotation. If not, they may experience rapid brush wear during continuous operation with the brushes stubbing.

Performance

Kinamatic motors meet NEMA standards for industrial equipment.

Regulation — See NEMA Standards.

Excitation — See modification pages or notes on price pages for standard shunt field voltages.

Parallel Operation — Where motors are to be operated in electrical and mechanical parallel, refer to **Wolong**.

V-Belt Drives

The V-belt system produces a heavy shaft and bearing loading, making it necessary that these factors be considered carefully for proper application. Since belt drives impose a bending moment on the motor shaft, it is always desirable to have the motor sheave located as close to the motor bearing as possible to minimize both bearing load and shaft stress. This will result in increased bearing life. The bearing life curves that follow assume the load is centered at the end of the shaft. Improved V-belts can significantly reduce the number and size of belts required for a given load. These new belts should always be considered, since the sheave will be shorter and the load centered closer to the bearing.

The standard NEMA shaft extension is designed for belted loads. Dimensions are provided on the standard dimension sheets. A sliding base is available as an accessory to facilitate belt adjustment.

Bearing Life

Bearing life for belted drives is determined by calculating the radial load at the end of the shaft.

The radial load, W , produced by the belts when tightened just enough to transmit the load without slipping is given by the relation:

$$W = \left(\frac{126,000}{D} \right) \left(\frac{HP}{RPM} \right) (K_b, \text{ lbs})$$

Where:

D = Sheave pitch diameter in inches for V-belt application.

$\frac{HP}{RPM}$ = Maximum ratio of horsepower, including overloads, to the minimum speed at which that power occurs.

K_b = Belt tension factor from table below:

BELT TENSION FACTOR, K_b	
K_b	Description
1.0	Chain and Sprocket Drive
1.2	Timing Belt
1.5	V-Belt, 1:1 Ratio
1.8	V-Belt, 2:1 Speed Decreased Ratio
2.0	Flat Belts

The curves which follow can be used to determine the L10 life, which is the life in hours that 90% of bearings with this load would be expected to exceed without failure. The standard ball bearing and standard shaft option will be the most economical, if acceptable life is obtained from the curve. A commonly used design figure is 20,000 hours.

Application Information

CD180AT-CD6900 Frames

However, applications with a calculated life of as low as 5,000 hours have sometimes been necessary to limit belt speeds to 6,000 feet per minute. The curves are drawn for 1750 RPM average speed. If the application has some other average speed, the life can be adjusted by multiplying by the bearing life factor curve. (See curve on right)

It is important to know that bearing life for V-belt applications is independent of the motor load. Once the belts have been tightened just enough to prevent slipping when the maximum torque is being delivered by the motor, the radial load, W , on the shaft and bearing is there and remains constant regardless of the motor load. For timing belts and chain drives, the radial load, W , does vary somewhat with motor load and so the motor load duty cycle, as well as the average speed should be considered to estimate bearing life.

If slippage occurs after the belt tension has been correctly adjusted, the belts and pulleys have not been chosen properly for the job.

Belt tension should be checked and adjusted following the belt manufacturer's recommendations.

There is normally a drop in tension during the first 24 to 48 hours of operation. During this "run in" period, the belts seat themselves in the sheave grooves and initial stretch is removed. Belt tension should be re-checked after a day or two of operation.

Matched belts run smoother, look better, and last longer. Longer belt life results if the belts and sheaves are kept clean and the belts are prevented from rubbing against the belt guards or other obstructions.

Mounting may be either horizontal or vertical for these bearing life determinations as long as no axial load other than the weight of the armature is present if vertical.

Special Load Considerations

Where the load is overhung beyond the motor shaft extension or greater life is desired, the application should be referred to **Wolong**.

Pinion Drives

While Kinamatic motors are not designed for overhung pinion drives, they may be successfully applied under suitable conditions. In addition to a radial load, some gears produce thrust load on the bearing. Vibrations, particularly of the torsional variety, are limiting on some spur or straight bevel gear applications. Complete details of the proposed gearing should be referred to **Wolong** in all cases.

Thrust Loads

Due to the mounting position or type of drive arrangement, a thrust load may be applied to the motor shaft. The Kinamatic motor is designed to permit a limited amount of thrust load. This permissible load will vary by mounting position and direction of the load due to the weight of the armature.

Bearing Life Factor vs. Speed

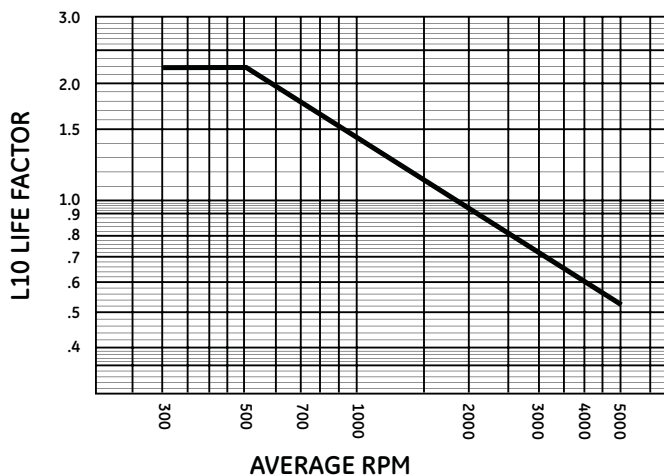

Application Information

BEARING LIFE AT 1150 RPM AVERAGE SPEED VS. LOAD, W
 (For other Average Speeds, multiply Life by $\frac{1150}{\text{AVG. SPD.}}$)
 Frame Sizes CD6000-CD6200

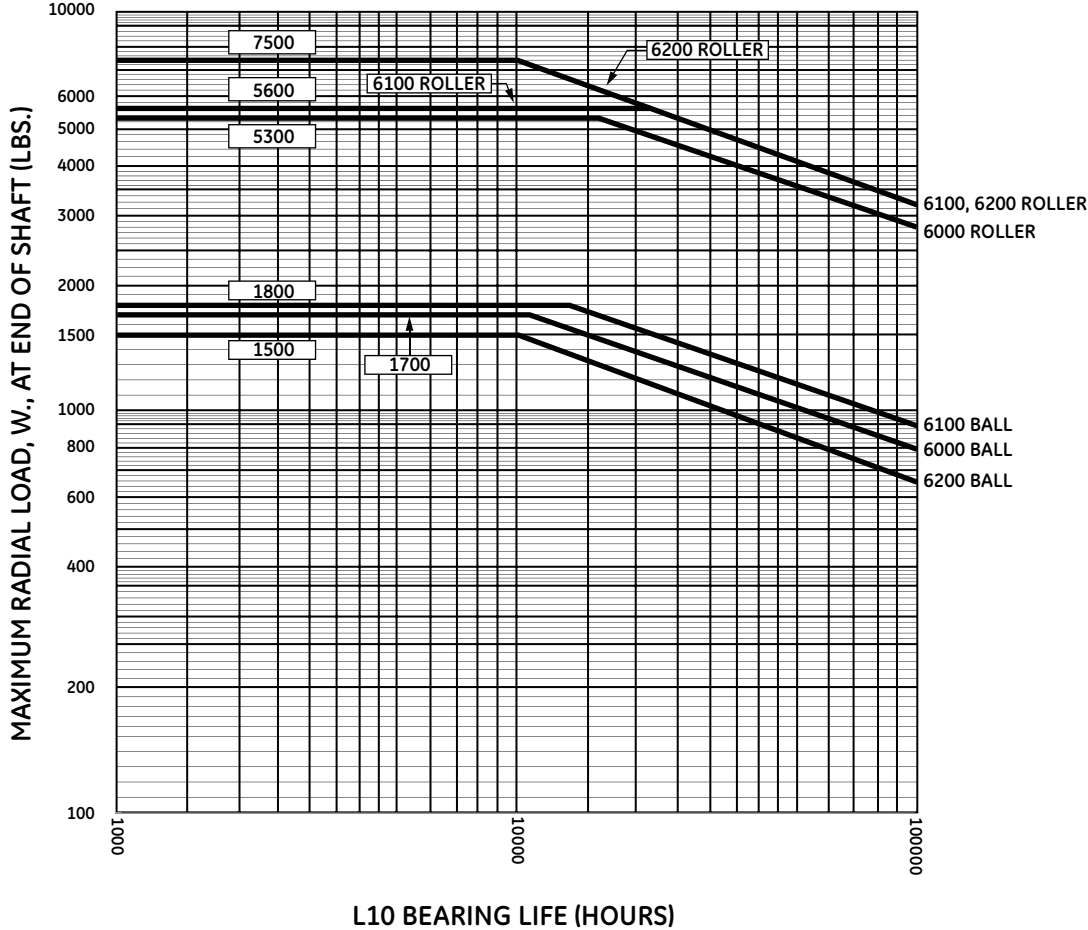

Application Information

Application Information

BEARING LIFE AT 1750 RPM AVERAGE SPEED VS. LOAD, W
 (For other Average Speeds, multiply Life by Life $\frac{1750}{\text{AVG. SPD.}}$)

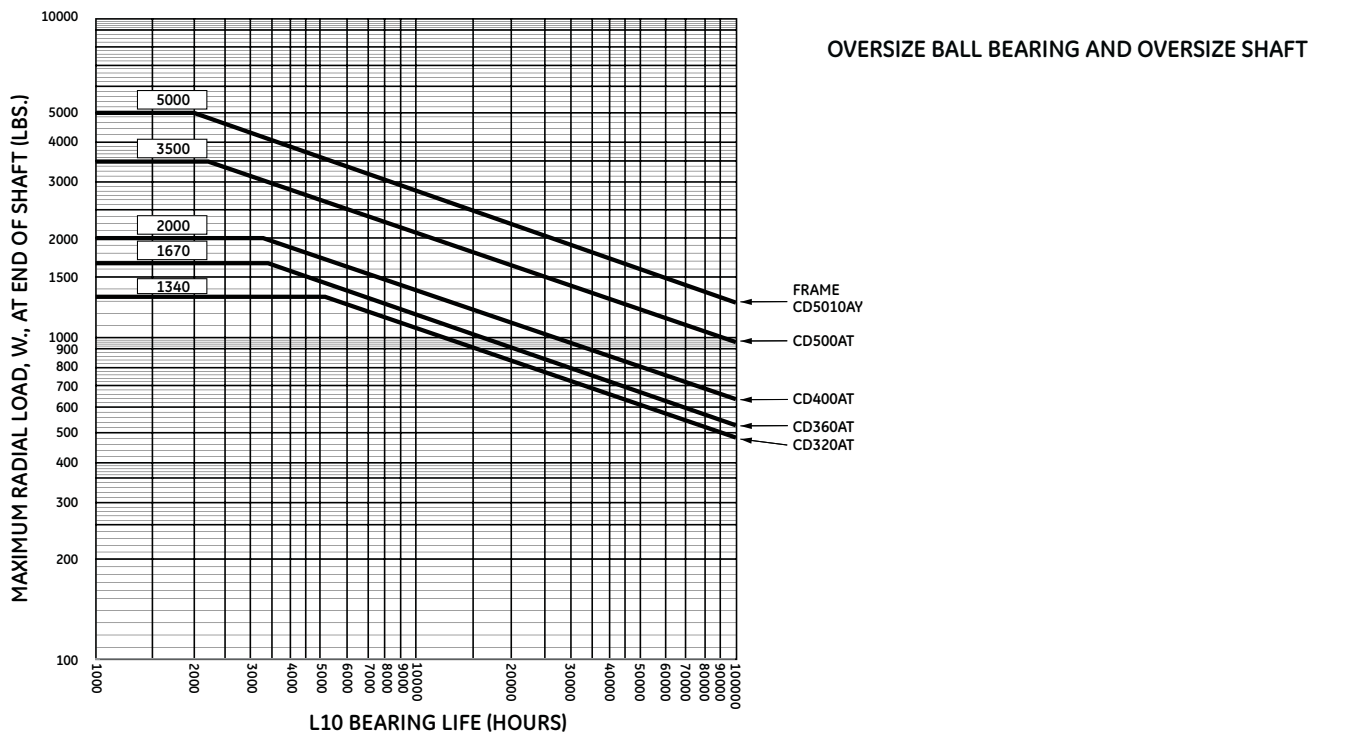
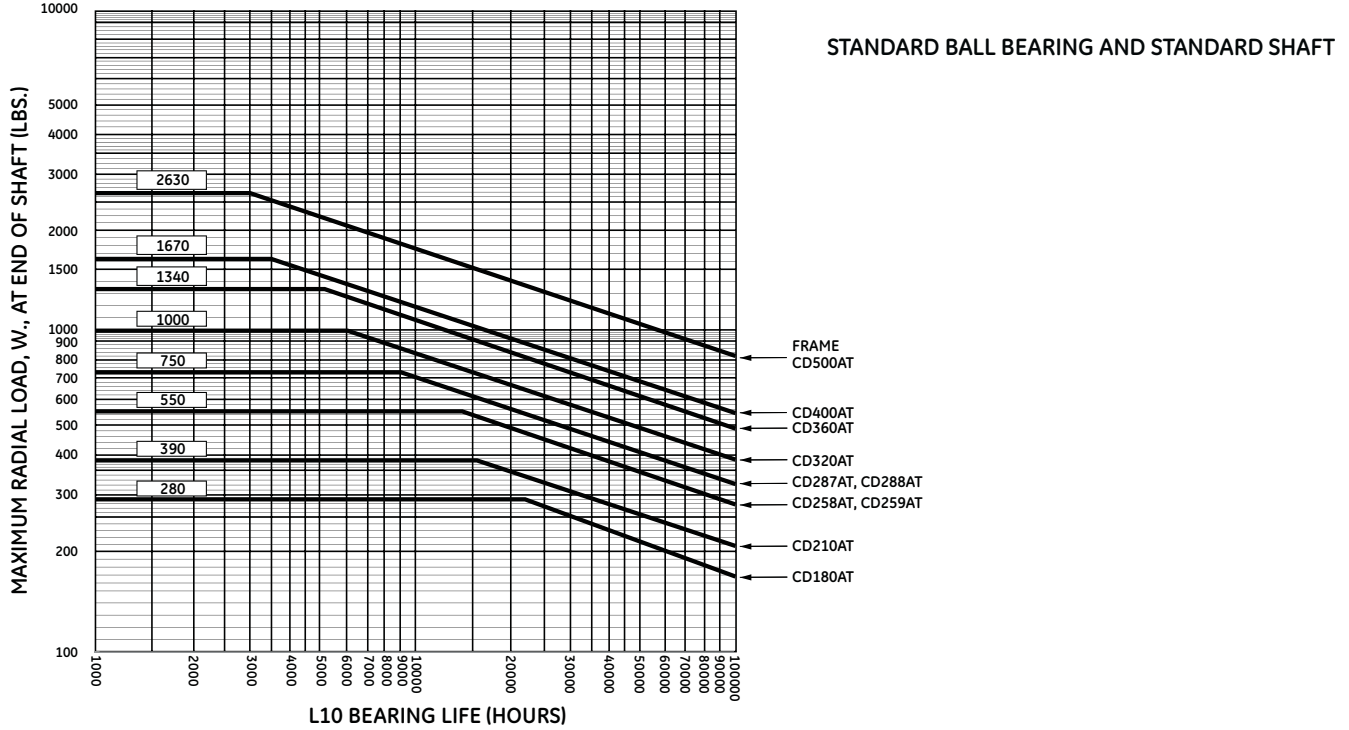

Application Information

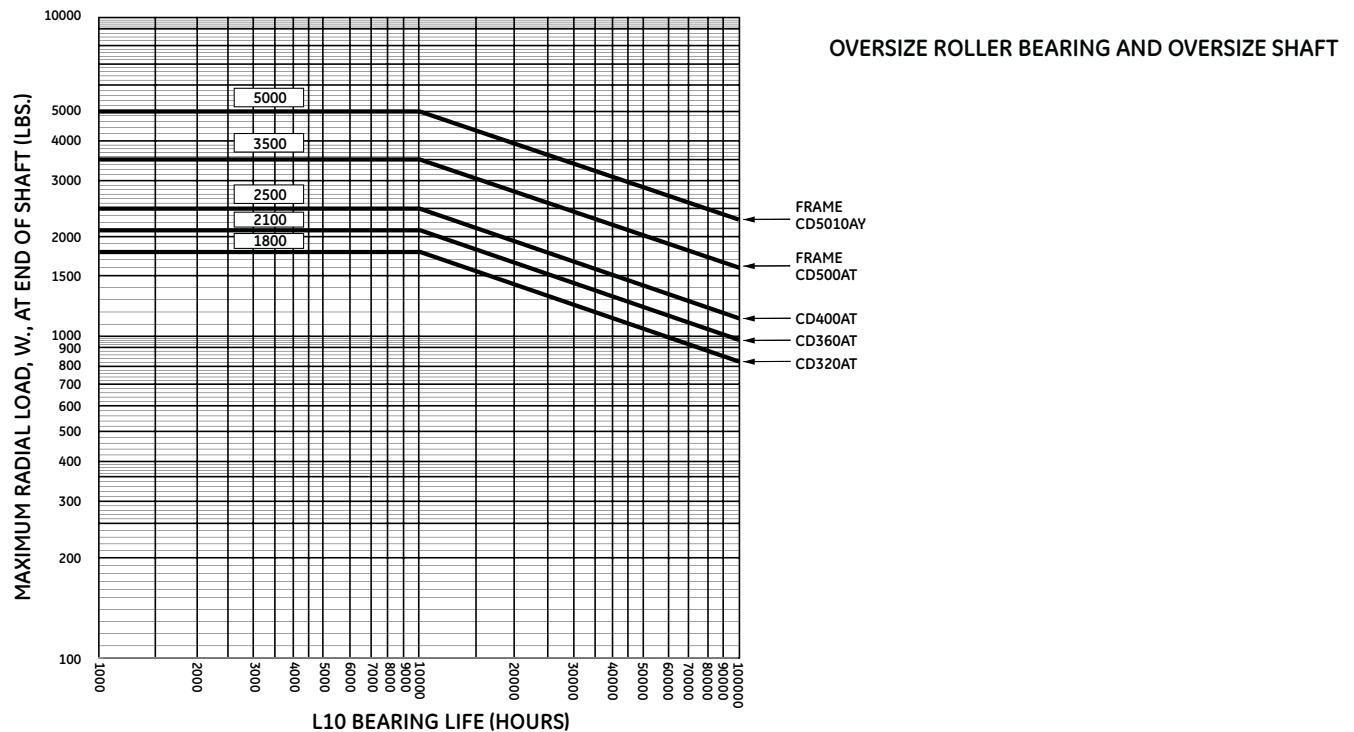
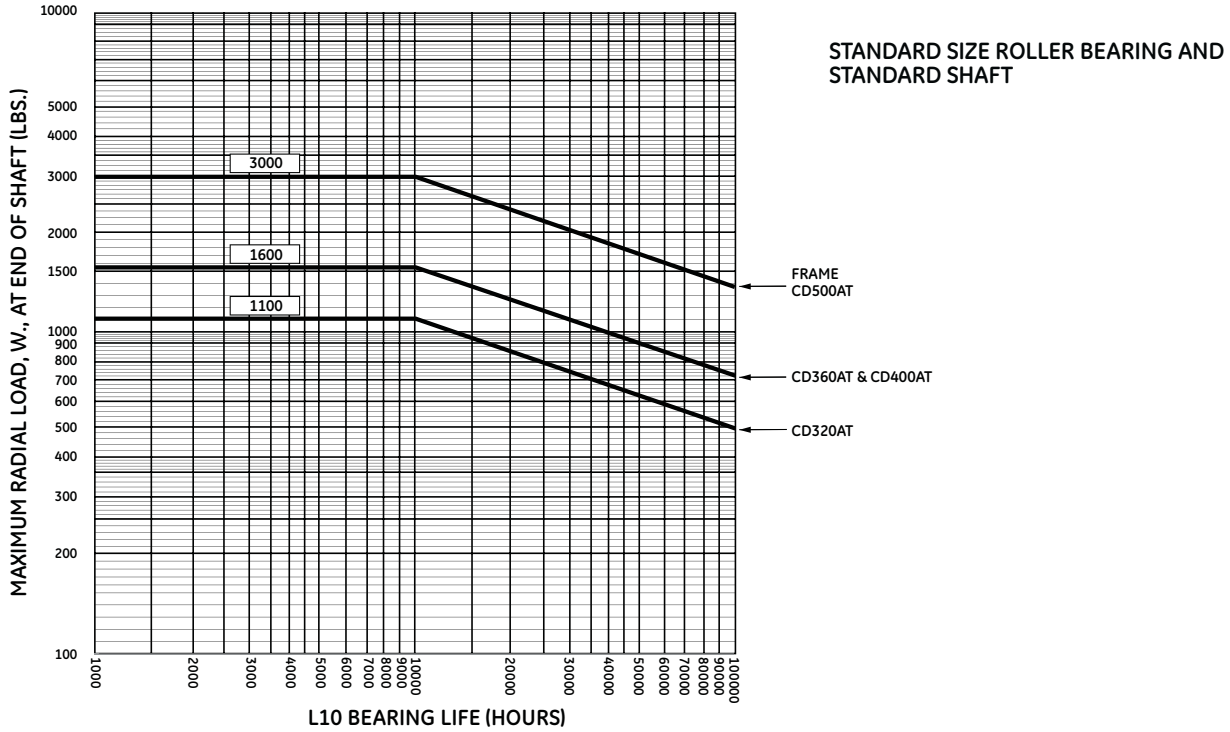

Application Information

Application Information

Power Supplies

When DC motors are operated from rectified power supplies, the pulsating voltage and current wave forms affect the motor performance by increasing motor heating and degrading commutating. Because of these effects, it is necessary that the motors be designed or specially selected to suit this type of operation.

A motor may, under some conditions, be operated from a power supply different from that indicated on the nameplate. Because the three letters used to identify power supplies in common use have been chosen in alphabetical order of increasing magnitude of ripple current, a motor rated on the basis of an "E" power supply may be operated from a "C" or "D" power supply, and a motor rated on the basis of "D" power supply may be operated from an "C" power supply but not necessarily from an "E" power supply. If it is desired to use a motor rated on the basis of a "C" power supply on either a "D" or "E" power supply, it may be necessary to add an inductance externally to the motor, in order to limit the ripple current to the magnitude implied in the rating. For more information see page 2.29 or contact **Wolong**.

The nameplates of DC motors intended for operation from rectified power supplies will be stamped with a Power Supply Identification as described under POWER SUPPLY IDENTIFICATION and the external reactance required, if necessary.

Audio Noise

Noise, by definition, is unwanted sound as is, therefore, a form of air pollution which must be kept under control. The occupational noise exposure standard promulgated by the Occupational Safety and Health Administration (OSHA) states that "protection against the effects of noise exposure shall be provided when the sound levels exceed those shown in table G-16 of the OSHA standard, when measured on the A scale of a standard sound level meter at slow response." It is important to note that this standard applies to the working environment and not to any specific device such as an electrical machine. Protection against noise exposure can be handled in three ways: reduction in the level of the noise source, reduction in the transmission of noise, and control of noise at the receiver by protective equipment.

Since the noise to which a worker may be exposed is a function of all the noise sources around him/her, as well as the acoustical characteristics of the area, it is impossible, without a detailed knowledge of these values, to predict sound pressure levels on the workers' ears. What is available is manufacturers' data taken under controlled conditions.

This data is generally taken at no load, at a specific distance from the source, and is measured in dB's of sound pressure with a reference pressure of 0.00002 N/m². Another measure of the intensity of the noise which is becoming more accepted is sound power. This is a measure of the intensity of the noise at its source. It is arrived at mathematically through an array of sound pressure readings. The units of sound power are also dB's with a reference power of 10¹² watts. This number is the noise level of the source and is independent of the surroundings. It can be used to predict resulting sound pressure levels.

Often, in talking of sound pressure, weighting networks will be specified. These are sound pressure readings with certain frequencies omitted to more nearly match the frequency response of the human ear (e.g. "A" network). While "A" network dB levels may be the same for two noise sources, it is important to realize that they may sound very different to the ear. The ear is much more sensitive to dB levels of a narrow frequency range. Discreet frequency sources may be objectionable, even though the overall "A" network dB level is moderate.

Typical values for the Kinamatic line of DP and TEFC frame diameters are given on the following pages. For guaranteed values, refer to **Wolong**. The values are in sound power and are no load readings taken using MG set power. (Noise levels at full load are essentially the same as no load for MG set power.) To estimate the average sound pressure, "A" network at some distance from the machine, use the curve on the following page to obtain the ΔdB to subtract from the sound power value.

Blower ventilated motors will generally be quieter than self-ventilated motors.

Adding one noise source equal to an existing noise source increases the total sound level 3dB.

Although the rectified magnetic noise levels for frames CD210AT-CD320AT never exceed 81 dB(A), rectified noise is in a limited frequency range and may be more objectionable to the ear than "white" noise, which consists of a variety of frequencies.

For average sound pressure (Lp) dB(A) of a hemisphere with a 3 ft. radius, subtract 7dB(A). For 6 ft. radius, subtract 13dB(A). For 10 ft. radius, subtract 17dB(A).

Application Information

FEET FROM THE CENTER BOTTOM OF THE MOTOR
(CENTER OF NOISE SOURCE)

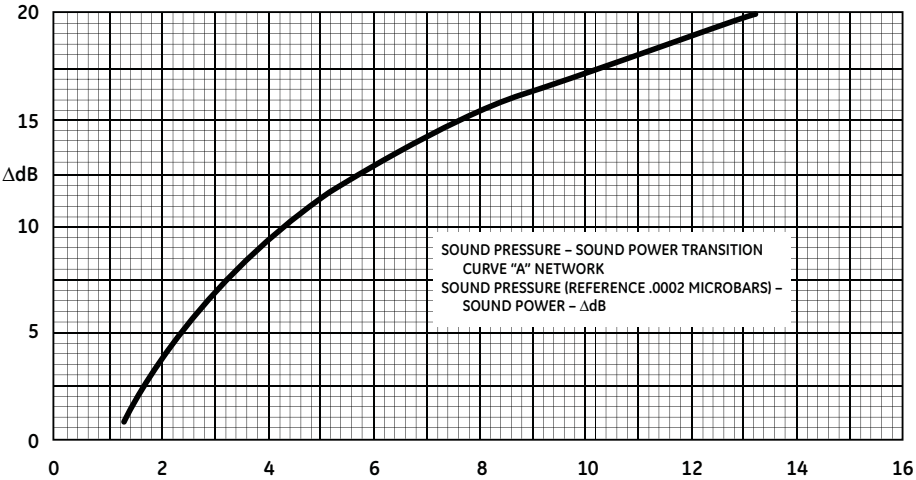

Application Information

The following noise levels have been measured on typical machines of the listed frame size and are not guaranteed limits.

NOISE LEVEL FOR TYPICAL DPGF DC MOTORS (With Internal Fan) Operated from MG Set Supply

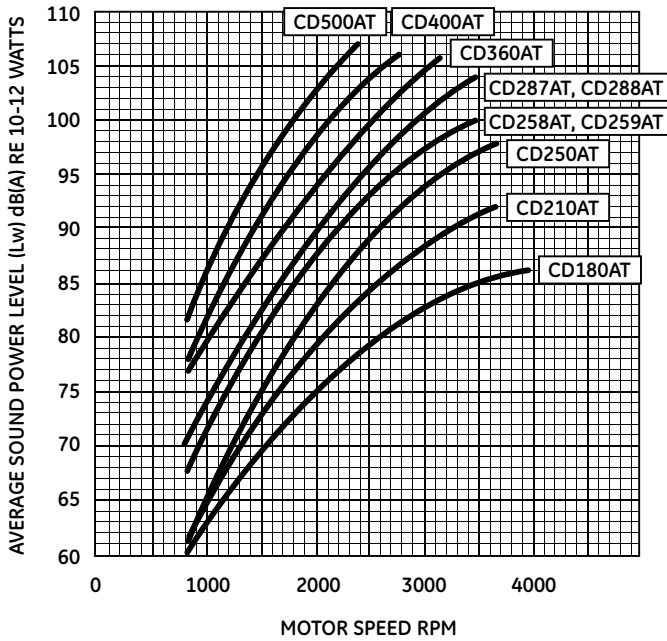

NOISE LEVELS FOR TYPICAL DPGF DC MOTORS Without Internal Fan (Enclosed Separately Ventilated but Without External Air Supply) Operated from MG Set Supply

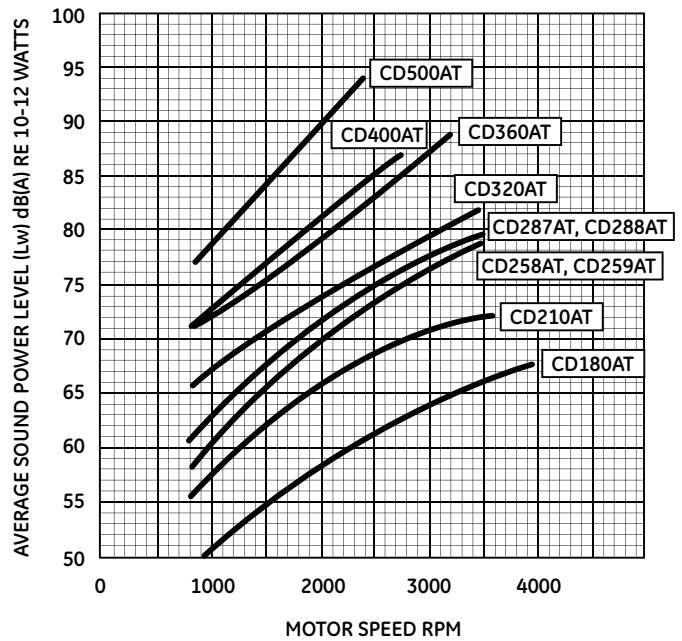

NOISE LEVELS FOR TYPICAL DPGF MOTORS WITH MOTOR MOUNTED BLOWERS Without Filter (Without Internal Fan) Operated From MG Set Supply

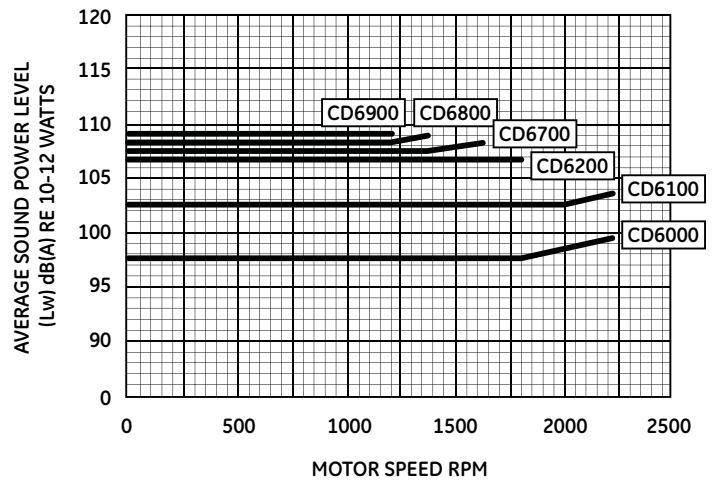
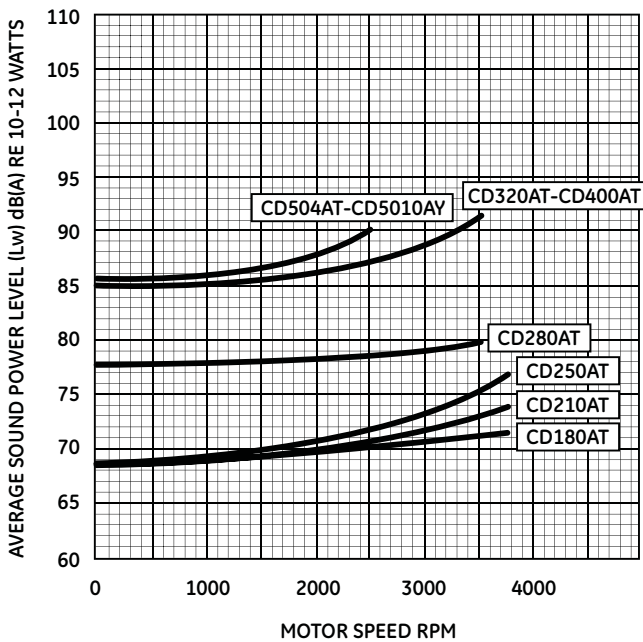

Application Information

Application Information

Air Flow Requirements for Separately Ventilated Motors

Frame	Base Speed RPM	CFM	STATIC PRESSURE INCHES OF WATER		
			A	B	C
			Standard Separately Ventilated	Enclosed Separately Ventilated	Blown From Drive End
CD180AT	3500	70	1.0	1.0	N/A
	2500	50	.6	.6	N/A
	1750*	35	.3	.3	N/A
CD210AT	3500	180	1.6	2.96	3.7
	2500	130	.8	1.5	1.9
	1750*	90	.4	.74	.9
CD250AT	3500	320	1.8	3.28	4.0
	2500	230	.86	1.66	2.0
	1750*	160	.45	.82	1.0
CD280AT	3500	540	2.16	3.92	4.3
	2500	385	1.04	1.96	2.4
	1750*	270	.54	.98	1.2
CD320AT	ALL	650	2.0	3.2	3.0
CD360AT	ALL	610	2.2	3.9	3.4
CD400AT	ALL	830	2.6	3.65	4.0
CD504AT- CD5010AY	ALL	1425	3.0	4.1	3.8

*1750 RPM or lower

A. Standard Separately Ventilated

Air in one CE opening with solid covers on other CE openings. Standard louvered covers on DE air outlets.

B. Enclosed Separately Ventilated (Air ducted in an air ducted out)

Air in one CE opening with solid covers on other CE opening. Air out one DE opening.

C. Blown From Drive End

Air in one DE opening with solid covers on other DE openings. Standard louvered covers on CE air outlets.

Frame	HP	Base Speed RPM	CFM	Static Pressure Inches of Water
CD6000	ALL	ALL	2400	3
CD6100	ALL	ALL	3400	3
CD6200	ALL	ALL	4000	5
CD6700	ALL	ALL	5000	5
CD6800	≤1500	ALL	6200	5
	>1500	ALL	8000	8
CD6900	≤2000	ALL	7500	5
	>2000	ALL	10000	9

NOTE: Airflows are for clean dry air less than 40°C (104°F) and at altitudes less than 1000 M (3330 FT).

WARNING:

The static pressure values listed in the tabulations are based upon standard air inlet and standard air outlet utilization. The static pressure will be higher if either the air inlet or outlet openings are restricted in size or, in the case of air outlets, reduced in number.

	CD5010AY and Below		CD6000 and Above	
	ESV	SV	ESV	SV
Standard Air Inlet Location	CE TOP	CE TOP	DE*	DE*
Standard Air Exit Location	DE (either side)	DE Side and Bottom	CE*	CE**

CE - Commutator End
DE - Drive End

ESV - Enclosed Separately Ventilated
SV - Separately Ventilated

*Motors are shipped with solid covers on both sides and top and bottom. Any DE cover may be removed for air entry and any CE cover for air exit. If a transparent cover is ordered, it will be located on the CE, conduit box side.

**If a transparent cover is ordered, air exit is opposite conduit box side and bottom. If not transparent cover is ordered, air is exited on both sides.

Application Information

Blower Data for Blower Ventilated Motors

Frame	HP	Volts [Ⓜ]	Hertz	Phase	RPM	Full Load Amperes	HP	Volts [Ⓜ]	Hertz [Ⓜ]	Phase [Ⓜ]	RPM	Full Load Amperes [Ⓜ]
CD180AT	1/12	230/460	60	3	3600	1.0/50	1/12	380	50	3	3000	N/A
CD210AT	1/12	230/460	60	3	3600	1.0/50	1/12	380	50	3	3000	N/A
CD258AT, CD259AT	1/12	230/460	60	3	3600	1.0/50	1/12	380	50	3	3000	N/A
CD287AT, CD288AT	1/3	200-230/460	60	3	3600	1.8/9	1/3	380	50	3	3000	0.76
CD320AT	1	200-230/460	60	3	3600	3.0/1.5	1	380	50	3	3000	1.6
CD360AT	1	200-230/460	60	3	3600	3.0/1.5	1	380	50	3	3000	1.6
CD400AT	1	200-230/460	60	3	3600	3.0/1.5	1	380	50	3	3000	1.6
CD504AT-CD5010AY	2	200-230/460	60	3	1800	5.8/2.9	2	380	50	3	1500	3.0
CD6000	5	230/460	60	3	1800	13.4/6.7	3	380	50	3	1500	5.2
CD6100	7.5	230/460	60	3	1800	19.6/9.8	5	380	50	3	1500	8
CD6200	10	230/460	60	3	1800	25.2/12.6	7.5	380	50	3	1500	11.4
CD6700	15	230/460	60	3	1800	38.8/19.4	10	380	50	3	1500	15.8
CD6800 <= 1500 HP	15	230/460	60	3	1800	38.8/19.4	10	380	50	3	1500	15.8
> 1500 HP	15	REFER TO GE										
CD6900 <= 2000 HP	20	230/460	60	3	1800	49.6/24.8	15	380	50	3	1500	22.4
> 2000 HP	20	REFER TO GE										

[Ⓜ] The use of a 50 Hertz blower may affect motor frame size and will affect motor price and delivery. Refer to **Wolong** for use of 50 Hertz

[Ⓜ] blowers. Full load amperes for blower motors are typical values.

[Ⓜ] Suitable for operation with up to ±10% variation from rated voltage (e.g. 207-253V/414-506V, 60 Hz; 342-418V, 50 Hz)

Application Information

Blower Data for TEAAC Motors

Frame ²⁶	Blower Motor Qty.	HP	Volts ²⁹ ²⁶	Hertz	Phase	RPM	Blower Motor Qty.	HP	Volts ²⁶	Hertz ³⁰	Phase	RPM
CD360AT	2	1/2	230/460	60	3	3600	2	1/2	380	50	3	3000
CD400AT and CD504AT-CD508AT "A" COOLER ²⁷	2	1	230/460	60	3	3600	2	1	380	50	3	3000
CD504AT-CD508AT "B" COOLER ²⁷	2	3	230/460	60	3	3600	2	3	380	50	3	3000
CD5010AY	1	5	230/460	60	3	3600	1	7.5	380	50	3	3000
	1	3	230/460	60	3	3600	1	3	380	50	3	3000
CD6000	2	5	230/460	60	3	3600	2	5	380	50	3	3000
CD6100	1	7.5	230/460	60	3	3600	1	7.5	380	50	3	3000
	1	5	230/460	60	3	3600	1	5	380	50	3	3000
CD6200	1	10	230/460	60	3	3600	1	10	380	50	3	3000
	1	5	230/460	60	3	3600	1	5	380	50	3	3000
CD6700	1	15	230/460	60	3	3600	1	15	380	50	3	3000
	2	5	230/460	60	3	3600	2	5	380	50	3	3000
CD6800 <= 1500HP	1	20	230/460	60	3	3600	1	20	380	50	3	3000
	2	7.5	230/460	60	3	3600	2	7.5	380	50	3	3000
> 1500HP	1	25	230/460	60	3	3600	1	25	380	50	3	3000
	2	7.5	230/460	60	3	3600	2	7.5	380	50	3	3000
CD6900 <= 2000HP	1	20	230/460	60	3	3600	1	20	380	50	3	3000
	2	7.5	230/460	60	3	3600	2	7.5	380	50	3	3000
> 2000HP	1	30	230/460	60	3	3600	1	30	380	50	3	3000
	2	10	230/460	60	3	3600	2	7.5	380	50	3	3000

Blower Data for TEWAC Motors

Frame ²⁸	HP	Volts ²⁹ ²⁶	Hertz	Phase	RPM	HP	Volts ²⁶	Hertz	Phase	RPM
CD508AT	7.5	230/460	60	3	3600	5	380	50	3	3000
CD6000	7.5	230/460	60	3	3600	7.5	380	50	3	3000
CD6100	7.5	230/460	60	3	3600	7.5	380	50	3	3000
CD6200	10	230/460	60	3	3600	10	380	50	3	3000
CD6700	15	230/460	60	3	3600	15	380	50	3	3000
CD6800 <= 1500HP >= 1500HP	20	230/460	60	3	3600	15	380	50	3	3000
	20	230/460	60	3	3600	20	380	50	3	3000
CD6900 <= 2000HP >= 2000HP	20	230/460	60	3	3600	20	380	50	3	3000
	30	230/460	60	3	3600	25	380	50	3	3000

²⁶ Suitable for operation with up to ±10% variation from rated voltage (e.g. 207-253V/414-506V, 60 Hz; 342-418V, 50 Hz).

²⁷ Refer to pages 4.21 and 4.22 for Kinamatic and pages 4.38 through 4.41 for CD6000, for cooler dimensions used on specific motor ratings.

²⁸ Severe duty high efficiency motor option is also available. Refer to **Wolong**.

²⁹ 575 volts also available, contact **Wolong** for more information.

³⁰ The use of 50 Hertz blower may effect motor frame size and will effect motor price and delivery. Refer to **Wolong** for use of 50 Hertz blowers.

Application Information

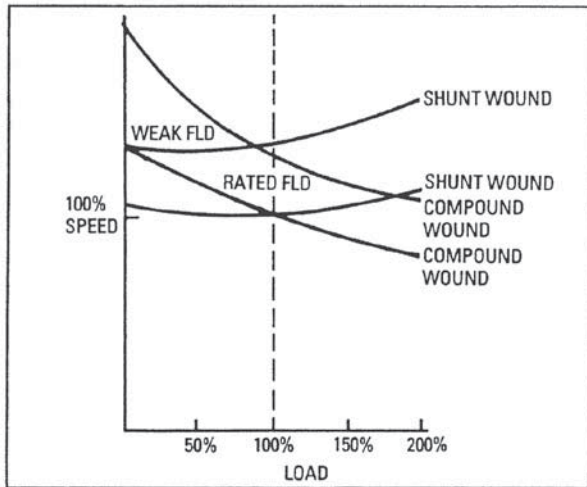

*Fig 1. Typical speed regulation

Motor Load Characteristics

Constant Torque Drives

Many industrial applications such as conveyors, mixers, cement kilns, squeeze rolls, continuous processing machines, etc., require nearly constant torque over their operating speed range. (Refer to Fig. 2.)

DC motors operated with fixed shunt field excitation and adjustable armature voltage have an approximately constant torque capacity over their speed range.

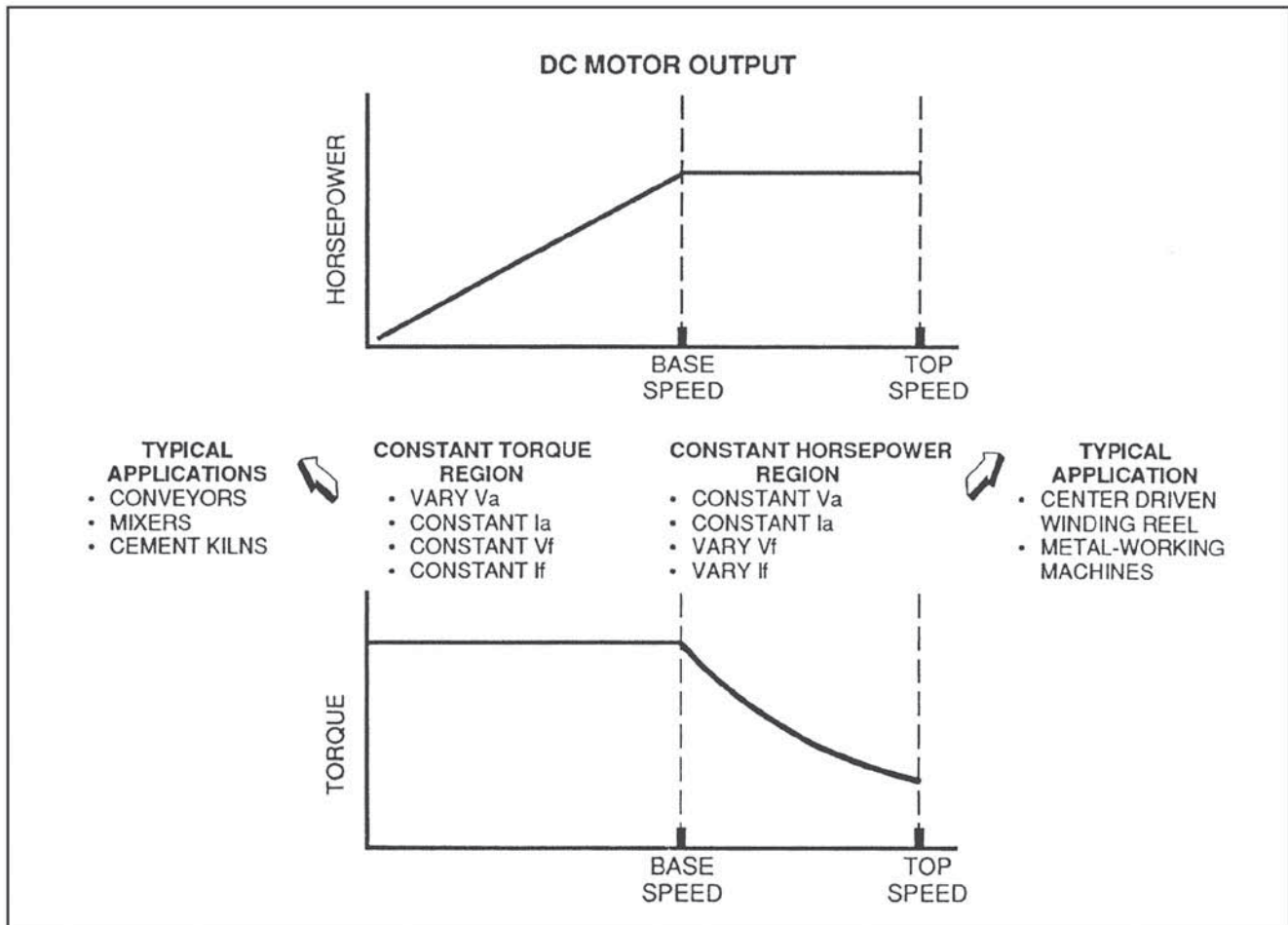

*Fig 2. Torque and HP Characteristics of constant-horsepower, constant torque load

Application Information

The load torque of a driven machine can be measured by wrapping a rope or cable around their input shaft or by using a torque arm and applying a steady pull through a spring scale. The horsepower can then be calculated using the following relation:

$$\text{HP} = \frac{\text{RPM} \times \text{Torque}}{5,252}$$

Stalled Current Capability

The Continuous Load section defines the torque capability at all speeds considering the thermal limits. While the curves may seem to indicate an intersection at zero speed, the data only applies at speeds other than zero, but may be very low, such as 10 RPM. At zero speed, localized heating of the segments under the brushes may produce segment distortion and resulting brush vibration.

Constant Horsepower Drives

A common example of a constant horsepower drive is a center driven winding reel. The material is wound on the mandrel at constant linear speed and constant tension using the following relation:

$$\text{HP} = \frac{\text{Linear Speed (FPM)} \times \text{Tension (lb)}}{33,000}$$

The horsepower is constant. At the start of the winding process, the torque requirement is low because of the small radius and the high rotational (motor) speed. As the roll builds up, the radius increases with a resulting increase in torque. The rotational speed must decrease in order to maintain constant linear speed.

The main drives of metal working machines require approximately constant horsepower because an optimum cutting speed is maintained for particular types of material regardless of the diameter of the surface being machined. When machining small diameter stock, the torque requirement is low and the rotational speed is high. Stock of larger diameters require higher torque and decreased rotational speed. DC motors operated by field control and a constant armature voltage have a constant horsepower capacity over the speed range. (See Fig. 2 on the previous page)

In some applications, constant horsepower may be required over a wider speed range than is obtainable by field control. The additional speed range must be obtained by armature voltage control. Horsepower and speed are approximately proportional to the applied armature voltage, and the

horsepower requirements of the load must be available at the lowest operating speed obtained by armature voltage control.

Combination of Constant Horsepower and Constant Torque

Applications such as the center-driven winding reel often require a combination of constant torque and constant horsepower. (See Fig. 2 on the previous page) The horsepower required for a given linear speed of material is constant during the build-up of a roll. However, it is often desirable to change the surface speed when reeling different material. Since horsepower is proportional to the surface speed, armature voltage control will provide for the surface speed adjustments while the field control will provide the constant horsepower requirement during the build-up of the roll.

Other Information

Index

	Page
Field Modification Kits	6.2
Recommended Spare Parts.	6.4
Standard Bearing Information	6.5

Field Modification Kits

Frames CD180AT to CD5010AY

Custom Modification Kits

Custom modification kits allow modification of Kinamatic™ motors which have been shipped from the factory. They are designed for maximum flexibility and ease of installation, and are stocked by authorized parts distributors to provide immediate availability.

The quick kit reference on the following pages lists the numbers of the most commonly used accessory kits and modification by frame size. Field modification kits cannot be mounted on all frame sizes or enclosures. Please review the application information carefully to determine availability. Contact **Wolong** (phone number available on page 6.4 of this document) or your parts distributor for kit prices.

The information given is not to be used for new motor specifications.

Application Information

Blower Kits

Blower kits are designed for standard mounting on the motor commutator end and for addition only to dripproof fully guarded, separately ventilated motors. Blower motors are 230/460 volt AC, 3 phase, 60 Hertz. To properly mount a blower kit on CD180AT frames, drilling and tapping of three holes is required.

Tachometer Kits

Tachometer kits are designed to be mounted on motors with an accessory comm end shaft extension of any fully guarded or totally enclosed Kinamatic motor, with the

exception of totally enclosed fan cooled (TEFC) machines. Tach adapters are made of cast iron and are supplied with appropriate covers. Refer to **Wolong** for mounting of tachometer kits on TEFC motors. **Note:** Type BC and Type PY tachometers must be ordered independently of the tachometer kits less tachometer.

Type C-Face Endshield Kits

Type C-Face endshield kits are designed for mounting on the fully guarded or totally enclosed nonventilated (TENV) frames listed below. Addition of Type C-Face endshield kits requires machine disassembly by a qualified service facility. For frames CD218AT-CD2010AT, refer to factory.

Frame Series	Standard C-Face Dimension (in inches)
CDL182AT-CD259AT	8.5
CD287AT & CD288AT	10.5
CD327AT, CD328AT, CD329AT	12.5

Sliding Bases

Sliding bases are suggested as a convenient means for adjusting belt tension or may be used as mounting plates. (For horizontal mounting only — not available for ceiling or sidewall mounting. Sliding bases not available on CD6000 frames and above.)

Lexan® Covers

Lexan covers are suggested as a convenient means of viewing brush rigging and brushes. Not available on frame sizes CDL182AT-CD189AT.

Frame Series	PY TACH KIT LESS TACH	BC TACH KIT LESS TACH	AN-AC TACH 45/90V/1000RPM (INCLUDES TACH)
CDL182AT-CD329AT	36A167701AAG01	36A167700AAG01	36A167702AAG01
CD365AT-CD368AT	36A167701BAG01	36A167700BAG01	36A167702BAG01
CD407AT-CDL409AT	36A167701CAG01	36A167700CAG01	36A167702CAG01
CD504AT-CD5010AY	36A167701CAG14	36A167700CAG01	36A167702DAG01

*Bi-directional, dual output.

Frame Series	AN-DG240L3 240 PPR ONE OUTPUT	AN-DG240L4 240 PPR DUAL OUTPUT	AN-DG600L3 600 PPR ONE OUTPUT	AN-DG600L4 600 PPR DUAL OUTPUT
CDL182AT-CD329AT	36C706050DA001	36C706050DB001	36C706050DC001	36C706050DD001
CD365AT-CD368AT	36C706050AB001	36C706050AB001	36C706050AC001	36C706050AD001
CD407AT-CDL409AT	36C706050AB002	36C706050AB002	36C706050AC002	36C706050AD002
CD504AT-CD5010AY	36C706050AB003	36C706050AB003	36C706050AC003	36C706050AD003

Field Modification Kits

Frames CD180AT to CD5010AY

DC PY TACH ONLY (USES PY KIT)		DC BC42 TACH ONLY (USES BC KIT)		DC BC46 TACH ONLY (USES BC KIT)	
50V/1000 RPM	897A594-002	50V/1000 RPM	897A590-032	50V/1000 RPM	897A591-041
100V/1000 RPM	897A594-001	100V/1000 RPM	897A590-024	100V/1000 RPM	897A591-029

Frame Series	BLOWER KIT LESS FILTER ⁽²⁸⁾	BLOWER KIT WITH FILTER ⁽²⁸⁾	C-FACE KIT ⁽³⁰⁾	LEXAN COVERS ⁽³³⁾ (Qty. 2 required)
CDL182AT-CD189AT	36A167741CAG01 ⁽²⁹⁾	36A167741CBG01 ⁽²⁹⁾	⁽³¹⁾	NOT AVAILABLE
CD218AT-CD2110AT	36A167742AAG02	36A167742ABG02	36A172472AAG01	36A167802BAG02
CD258AT-CD259AT	36A167743AAG02	36A167743ABG02	36A172473AAG01	36A167803BAG02
CD287AT-CD288AT	36A167744AAG03	36A167744ABG03	36A172474AAG01	36A167805BAG02
CD327AT-CD329AT	36A167745GAG10	36A167745GBG10	36A172475AAG01	36A167806BAG02
CD365AT-CD368AT	36A167746GAG10	36A167746GBG10	NOT AVAILABLE	36A167807BAG02
CD407AT & CD409AT	36A167747GAG10	36A167747GBG10	NOT AVAILABLE	36A167809BAG02
CDL407AT & CDL409AT	36A167747GCG10	36A167747GDG10	NOT AVAILABLE	36B473083CAG01
CD504AT-CD5010AY	36A167749EAG30	36A167749EBG34	NOT AVAILABLE	36B473084CAG01

Frame Series	Sliding Base
CDL182AT	533C400-034
CD186AT	533C400-001
CDL186AT	533C400-001
CD189AT	533C400-023
CD218AT	533C400-019
CD219AT	533C400-022
CD2110AT	533C400-039
CD258AT	533C400-040
CD259AT	533C400-041
CD287AT	533C400-020
CD288AT	533C400-042
CD327AT	533C400-043
CD328AT	533C400-044
CD329AT	533C400-067
CD365AT	533C400-011
CD366AT	533C400-012
CD368AT	533C400-046
CD407AT	533C400-047
CDL407AT	533C400-047
CD409AT	533C400-048
CDL409AT	533C400-048
CD504AT	533C400-017
CDL504AT	533C400-017
CD506AT	533C400-049
CDL506AT	533C400-049
CD508AT	533C400-050
CDL508AT	533C400-050
CD5010AY	533C400AK001

⁽²⁸⁾ Blower motor is 230/460 Volt AC, 3 phase, 60 Hertz.

⁽²⁹⁾ Requires drilling and tapping of three holes to install.

⁽³⁰⁾ Requires motor disassembly by qualified service facility to install.

⁽³¹⁾ For dripproof motors use 36A172471AAG02. For totally enclosed motors use 36A172471AAG01.

⁽³³⁾ For commutator end only.

Recommended Spare Parts List

Renewal Parts Service

The Kinamatic motor is designed for tough industrial applications. Maintain the original performance standards of the Kinamatic design by using genuine renewal parts.

Kinamatic renewal parts, such as main and commutator coils, pole assemblies, and armature coils are produced to original factory specifications including form fits, materials, and dimensions.

A permanently attached stainless steel nameplate displays the model and serial number, providing all the information needed for ordering.

Recommended Spare Parts

As insurance against costly downtime, it is strongly recommended that spare parts be kept on hand in accordance with the chart below:

Description	NUMBER OF DUPLICATE MOTORS IN SERVICE				
	1	2-4	5-10	11-20	More Than 20
Complete Machine	-	-	-	1	2
Drive End Ball Bearing	1	1	1	2	3
Front End Ball Bearing	1	1	1	2	3
Brushes (Sets)	2	4	4	8	10
Brushholders (Sets)	-	1	1	1	1
Brushholder Springs (Sets)	1	1	1	2	2
Main Field Coil and Pole	-	1	1	2	3
Commutating Field Coil and Pole	-	1	1	2	3
Armature, Complete	-	1	1	2	2

Standard Bearing Information

The following chart shows the standard ball bearings used in Kinamatic motors. This chart does not apply to motors with roller bearings. Non-standards are manufactured for special applications. Therefore, not all Kinamatic motors follow the chart below. Refer to **Wolong** for non-standard motors.

STANDARD BEARINGS FOR DC MOTORS						
Frame Size	DRIVE END			COMM END		
	Bearing Size	AFBMA #	GE Part Number	Bearing Size	AFBMA #	GE Part Number
CD140AT	6205	25BC02JPP3	894A605ZJ 005	6204	20BC02JPP3	894A605ZJ 004
CD180AT	6206	30BC02JPP3	894A605ZJ 006	6206	30BC02JPP3	894A605ZJ 006
CD210AT	6207	35BC02JPP3	894A605ZJ 007	6206	30BC02JPP3	894A605ZJ 006
CD250AT	6209	45BC02X3	894A605 009	6207	35BC02X3	894A605 007
CD280AT	6210	50BC02X3	894A605 010	6209	45BC02X3	894A605 009
CD320AT	6211	55BC02X3	894A605 011	6210	50BC02X3	894A605 010
CD360AT	6213	65BC02X3	894A605 013	6211	55BC02X3	894A605 011
CD400AT	6214	70BC02X3	894A605 014	6213	65BC02X3	894A605 013
CD504AT/CD508AT	6218	90BC02X3	894A605 018	6216	80BC02X3	894A605 016
CD5010AY	6222	110BC02X3	894A605 022	6218	90BC02X3	894A605 018
CD6000	6224	120BC02X3	894A605 023	6220	100BC02X3	894A605 020
CD6100	6228	140BC02X3	894A605 025	6224	120BC02X3	894A605 023
CD6200	6232	160BC02X3	894A605 027	6228	140BC02X3	894A605 025
CD6700	6236	180BC02X3	894A605 029	6236	180BC02X3	894A605 029
CD6800	6236	180BC02X3	894A605 029	6236	180BC02X3	894A605 029
CD6900	6240	200BC02X3	894A605 031	6240	200BC02X3	894A605 031

Our DC Motors Last! And we back up that claim.

GE direct current motors are legendary in the industry for their durability, reliability, and longevity!

We have over 100 years of experience of direct current motor engineering and manufacturing utilizing superior design and quality control systems. These machines are a proven reliable lifeline to driven equipment and the backbone of thousands of operations around the world.

- They are constructed in a rugged magnetic ring frame for severe industrial duty applications.
- They feature anti friction bearings with removable bearing cartridges and caps.
- Fully compliant class F insulation (CD) and class H insulation (MD).
- Strong Tungsten Inert Gas (TIG) welded commutator risers to the armature coil.
- Tape Reinforced Encapsulated Construction (TREC) of main field coils and commutating field coils is a process which strengthens, seals, and bonds the coil and pole into a single unit highly resistant to contaminants.



As of July, 2024 Wolong is offering a 5 year manufacturer's warranty on these GE direct current motor models:

Mill-Duty Series
MD600Z, MD800

CD Series
CD6000, CD8000, CD9000,
and MCF Generators

The warranty is valid for the period of 54 months from the date of installation or 60 months from the date of manufacture, whichever comes first, guaranteeing to the Buyer that the provided product will be free from defects in material, workmanship, and title. For more information, please contact your Wolong representative.



www.wolongamerica.com

WOLONG

Power your future



www.wolongamerica.com

Kinamatic and TREC are trademarks of Wolong Electric America LLC.
Alvania and Aeroshell are trademarks of Shell Oil Company. Excellon is a trademark of eXellon Technologies, Inc.
Polyrex EM is a trademark of Exxon Mobil Corp. RIM Tach and SLIM Tach are trademarks of Dynapar.
SMARTach II and THIN-LINE II are trademarks of Avtron Industrial Automation, Inc. NEMA Premium is a trademark of NEMA.
GE is a trademark of General Electric Company. Manufactured under trademark license.
©2024 Wolong Electric America LLC. All rights reserved.
GEP387-EN (8/2024)